

Monitoring Mobile Flows in Emerging IPv6 Access Networks – Concepts and First Prototype

Pedro Marques^{1,2}, Helder Castro^{1,2}, and Manuel Ricardo^{1,2}

1. FEUP - Fac. Eng. Univ. Porto, Rua Dr. Roberto Frias, 378, 4200 Porto, Portugal
2. INESC Porto, Campus da FEUP, Rua Dr. Roberto Frias, 378, 4200 Porto, Portugal

Abstract

This paper describes a simple network monitoring system capable of capturing packet information and identifying mobile IPv6 flows. The mechanism devised to detect flow mobility is the key contribution of this paper.

1 Introduction

The emergence of 4th Generation communication scenarios, or Systems Behind 3rd Generation, is forcing a new class of access networks to appear. This class of networks, possibly based on IPv6, will provide access to mobile and wireless terminals, and will support a diversity of layer 2 networks, that include 802.11, GPRS, UMTS, and Bluetooth. The provisioning of real time services over IP will force these networks to support QoS. The wireless access will also force them to adopt new security, authorisation and accounting mechanisms.

The study and characterisation of these access networks demand new traffic monitoring tools. Existing tools, such as NET-FLOW [19], monitor and sample traffic in selected network elements, and characterise it as flows. However, these tools are usually oriented to core networks, and lack the functionalities required to represent mobility properties and wireless aspects.

This paper presents results obtained in a final course project. The main objective of this project is to understand the characteristics of new test tools, capable of monitoring flows in IPv6 access networks supporting mobile terminals. A simple but representative network was first laid out and

configured, supporting Mobile IPv6 over 802.11b. Using this configuration, a simple monitoring system was designed. It captures packet information, identifies flows, and is starting to incorporate concepts related to the mobility of terminals and flows.

The paper is organised in 6 sections. Sec. 2 introduces IPv6. Sec. 3 describes Mobile IPv6. Sec. 4 addresses wireless LANs. Sec. 5 introduces the architecture of the implemented monitoring system and describes the testbed used to perform the experiences. Finally, Sec. 6 concludes the paper.

2 The IP Next Generation

IPv4 uses 32 bit addresses, allowing for 4 billion addresses. But given its address assignment inefficiency and the rising number of internet users, IPv4 is suffering from growing address space exhaustion [14].

In July 1992, the IETF started to work on a new proposal for the next-generation IP, (IPv6) [3]. The recommendation has already been issued [5], and several other related [6], [9] have subsequently been developed.

2.1 Addressing architecture

IPv6 uses 128-bit addresses, which allow for far more addresses than IPv4, and have

a hexadecimal notation with 2 “nibble” (16 bits) colon separator, such as:

$2^{128}-1 =$
 ffff : ffff : ffff : ffff : ffff : ffff : ffff : ffff

For easy address representation, 16 bit blocks containing only zeroes can be replaced with “:”[8]. IPv6 defines unicast, multicast, and anycast addresses[6].

An unicast address is assigned to a network interface, and it can be of 4 types: 1) loopback, ::1/128; 2) link-local, that is local to a *link* and not passing the routers; 3) site-local, that is local to a network, passes local routers, and can be used to subnet the local network; 4) global, for addressing an host globally.

An anycast address identifies a set of interfaces, and allows finding a sort of nearest machine (router, DNS server, or DHCP server). A multicast address is used to represent a group of interfaces, all of them receiving the packet.

In most of the address types, the lower 64 bits of an address represent the host part. The host part can be auto configured by IPv6 that, using the IEEE EUI-64 method [6], converts the network interface MAC address into a unique address.

2.2 The IPv6 packet

| |
|----------------------------|
| IPv6 header |
| Hop-by-hop options header |
| Routing header |
| Fragment header |
| Authentication header |
| ESP header |
| Destination options header |
| Mobility header |
| TCP header |
| DATA |

The IPv6 packet has a fixed size header, which may be complemented by a set of extension headers: Hop-by-hop options, Routing, Fragment, Authentication, ESP, Destination options, and mobility (not yet standardised) [14]. To accelerate router processing of IPv6 packets, extensions headers are included in each packet in the order indicated, according to the required communication functionalities.

2.3 IPv6 advantages and costs

When compared to IPv4, the IPv6 protocol expands the address space to meet future addressing requirements, and speeds up router processing and forwarding. By enabling flow labelling, it also eases the support of QoS and traffic engineering. The auto-configuration mechanism [10], enables an host to plug a network and start working immediately.

The IPv6’s main problem is its deployment affordability. However, the increasing costs of maintaining IPv4 using tricks such as NAT and DHCP, may help IPv6 overcome this problem [11].

3 Mobile IPv6

The Mobile Internet Protocol v6 (MIPv6) is a new IPv6 standard emerging at IETF [13]. It enables terminals to roam transparently between networks, wired or wireless, without disrupting their connections.

A host machine may have some active TCP connections associated to its IP address (home address). When moving from its home network to a foreign network, the terminal has to obtain a new address from the visited network - the Care-Of-Address (COA) – but also maintaining its home address, so that the active TCP sessions may continue alive.

Mobile IPv6 addresses mobility as a routing problem. This protocol is characterised by: 1) a new extension header, the Mobility Header, used for binding cache management; 2) the concept of route optimisation, supported by the Routing Header; 3) new ICMP messages (e.g. Router Advertisements used to inform the moving terminal about networks and gateways); 4) a new IPv6 Destination option – the Home Address Option, 5) a new Mobility Header, carrying messages like Binding Updates / Acknowledgments, used to inform other nodes of the Mobile Node’s Care-of Addresses.

There are three types of network elements defined in MIPv6: 1) the Mobile Node (MN); 2) the Home Agent (HA), that represents the MN when it has roamed; 3) the Correspondent Node (CN), that symbolizes generic IPv6 aware hosts.

When a MN links to a foreign network it must get an address from this network. MIPv6 provides a Neighbour Discovery mechanism [9] that enables the MN to listen to the Router Advertisement messages issued by a router in the visited network and by auto-configuring a new COA from the visited network.

The COA enables the MN to communicate with the Internet. In order to avoid loosing the active TCP connections, but also to receive data sent to its home network, the MN sends a Binding Update message to its HA, which sets a tunnel to the MN. This tunnel is used to relay the packets received at the home network to the MN.

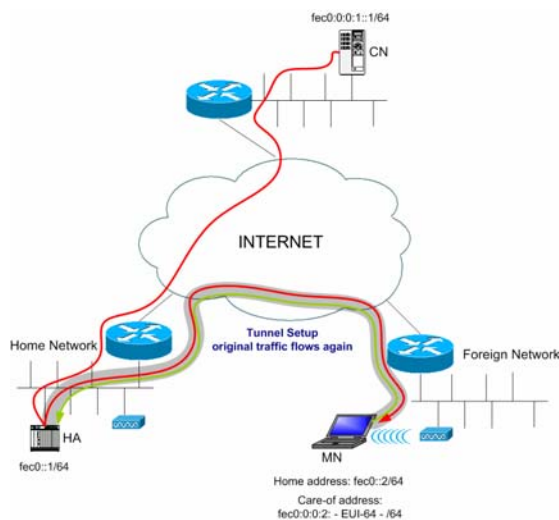

Figure 1 - Tunnel setup between the Mobile Node and the Home Agent.

In order to improve routing efficiency, the MN also registers its current COA with the CN. Afterwards, the CN starts to communicate directly with the MN using the COA, and appending a new Routing Header to IPv6 packets. When the MN receives a packet addressed to the COA, it inspects the Routing Header, and forwards the packet to the next Hop that, in this

case, is its home address. Thus, the MN simply loops back the packet. Packet tunnelling (HA-MN) is only used before the CN gets the “binding” for the MN.

4 Wireless LANs

Wireless Local Area Networks (WLANs) are generally confined to restricted areas and provide high speed data connectivity to wireless terminals. The most popular standard for WLANs is IEEE 802.11 [15] enabling 2 network configurations: ad-hoc and structured.

In ad-hoc mode there is no structure at all. Stations select a communication channel, associate themselves with a Basic Service Set (BSS) and talk directly with hosts in the same BSS.

In structured mode, a wired structure interconnects a set of transceivers, called Access Points (APs), that controls the communication between wireless nodes. A BSS consists of a set of Mobile nodes using the same Access Point and under the same radio coverage.

IEEE 802.11 regulates communication at MAC and Physical layers. Interaction with other type of networks is possible by bridging the networks [17]. Figure 2 illustrates this situation for a wired IEEE 802.3 network [18].

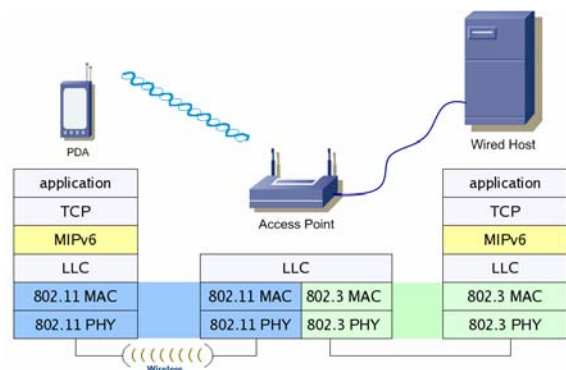

Figure 2 - Interface between wireless 802.11b and wired 802.3 networks, with MIPv6.

5 Monitoring Architecture

The architecture of the envisaged and implemented monitoring system is distributed, software based, and capable of being integrated in generic access network topologies. It assumes also that packet capturing and sampling may be performed at any IP network element (edge router, internal router, and even mobile nodes). It consists of two types of components – the Sampler and the Collector.

The Sampler is the entity in charge of gathering information about the traffic traversing a network element. It captures and filters the packets exchanged through network interfaces, and stores relevant information about these packets in a table.

The Collector is a central unit in charge of processing the information gathered and regularly flushed by the samplers.

Access network traffic is modelled as flows. A traditional packet flow describes a set of packets observed close in time and having a set of common characteristics such as addresses and, sometimes, protocol and ports. A Mobile IPv6 flow inherits these characteristics, and it is characterised by (1) source IPv6 address, always an home network address, (2) destination address, also an home network address, (3) source port, (4) destination port, and (5) protocol (e.g., TCP, UDP, IPIP). Packets having the same values for these fields, and close in time, are classified as belonging to the same flow. The flow label field can, in alternative, be also used.

The information registered by the Sampler for each packet depends on the measurements. At least, the packet length and the time stamp are registered. Care-of-Address, QoS related parameters, TCP flags or sequence numbers, are examples of other values to register. This information may be used not only to reason about mobility but also about Quality of Service and network performance.

Each sampler forms, in real-time, a flow table with packet information which it flushes regularly to the collector. The collector receives these tables from samplers and builds a new structure, where all the flow and packet information available are merged. The result is a global view of the network, organized by flows or aggregated flows.

Figure 3 shows a network configuration in which this monitoring system can be used. The wireless edge routers provide access to mobile terminals. All the routers, internal and edge, have a sampler installed. Although not required, mobile terminals may also have a sampler installed.

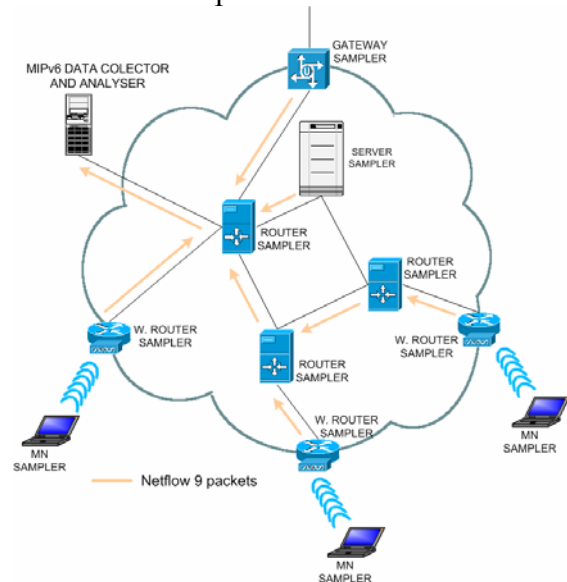

Figure 3 - Sample network configuration and tests architecture.

5.1 Flow mobility tracking

The new concept introduced by this project is flow mobility tracking. A mobile flow may traverse, during its life, a set of router sequences.

In order to track a flow when one (or two) of its extremities moves, the Collector permanently needs information from the routers. It must also be aware of Care-of-Addresses and sampler/interfaces. In the Collector, however, a flow is always identified by the IP addresses (source or desti-

back to the home network again. The flat portions of the line (which are in fact several overlapped lines, one for each sampler/interface) represent the instants when the mobile node has roamed.

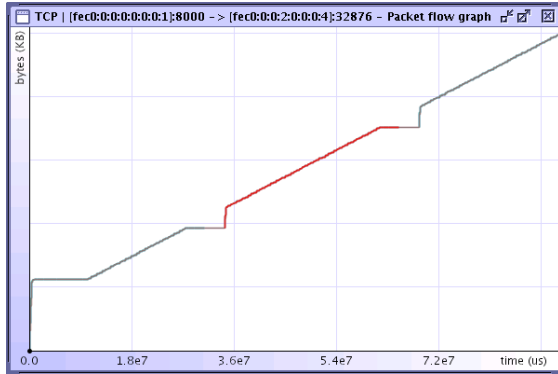

Figure 6 - Accumulated packet sizes vs time from a single flow.

Furthermore, a simple network analyser was also developed which, based on the information collected from the samplers, sketches the logical topology of the access network. The analyser is user interactive, supplying on-demand statistics and metrics, plotting and tracking flows as well as providing MN position detection. Figure 7 gives the analyser overview.

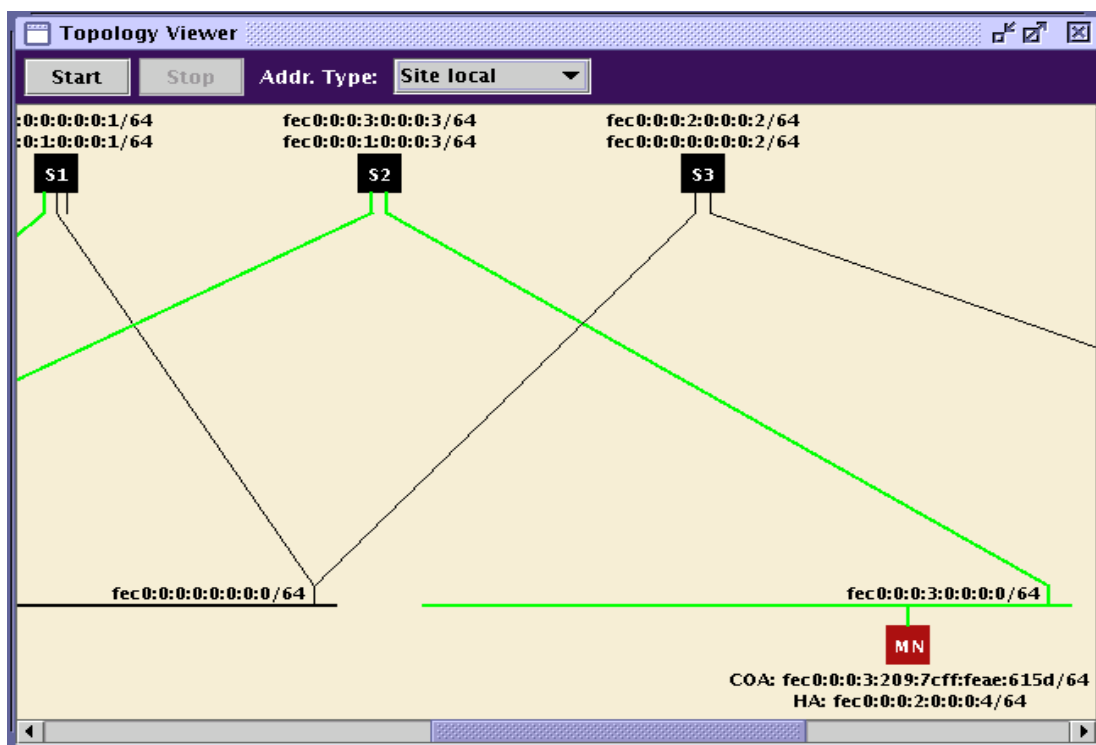

Figure 7 - Logical topology of the network, drawn by the network analyser.

The Collector can also compute relevant metrics that enable the characterisation of the access network. These metrics address aspects related to mobility, connectivity, traffic characterisation and network performance. Examples are flow duration, packet delays, packet loss, and throughputs.

6 Conclusions

This paper presents the preliminary results of a final course project. A simple but functionally representative access network supporting Mobile IPv6 over 802.11b has been installed. It uses 3 routers, 2 access points, and one mobile terminal.

Using this testbed as case study, a system for monitoring mobile flows started to be developed. It consists of a set of samplers gathering packet information at IP network elements, and a collector that computes the information sent by samplers and represents it as arrival/departure curves.

The mechanism used to identify moving flows uses the type 2 Routing Header and

the Destination Options Header, also allowing to track the current visited network.

This simple architecture is now being evaluated. Based on this evaluation, new requirements will be defined so that, gradually, the tool can start to be used in the new IPv6 access networks supporting mobility.

7 References

- [1] IPv6 Organization. IPv6 Information Page. <http://www.ipv6.org>
- [2] IPv6 Working Group. P Version 6 Working Group (ipv6). <http://www.ietf.org/html.charters/ipv6-charter.html>
- [3] Robert M. Hinden. IP Next Generation Overview. <http://playground.sun.com/pub/ipng/html/INET-IPng-Paper.html#CHI>
- [4] USAGI Project. USAGI Project-Linux IPv6 Development Project. <http://www.linux-ipv6.org/>
- [5] S. Deering and R. Hinden. RFC 2460: Internet Protocol, Version 6 (IPv6) Specification, December 1998. <http://www.ietf.org/rfc/rfc2460.txt?number=2460>
- [6] R. Hinden and S. Deering. RFC 3513: Internet Protocol Version 6 (IPv6) Addressing Architecture, April 2003. <http://www.ietf.org/rfc/rfc3513.txt?number=3513>
- [7] A. Conta and S. Deering. RFC 2463: Internet Control Message Protocol (ICMPv6) for the Internet Protocol Version 6 (IPv6) Specification, December 1998. <http://www.ietf.org/rfc/rfc2463.txt?number=2463>
- [8] R. Elz. RFC 1924: A Compact Representation of IPv6 Addresses, Apr-01-1996. <http://www.ietf.org/rfc/rfc1924.txt?number=1924>
- [9] T. Narten, E. Nordmark and W. Simpson. RFC 2461: Neighbor Discovery for IP Version 6 (IPv6), December 1998. <http://www.ietf.org/rfc/rfc1924.txt?number=2461>
- [10] S. Thomson and T. Narten. RFC 2462: IPv6 Stateless Address Autoconfiguration, December 1998. <http://www.ietf.org/rfc/rfc1924.txt?number=2462>
- [11] Tim Chown, Jeff Doyle, Gary Hemminger, Latif Ladid, L-F Pau, Yurie Rich and Renice A. Stewart-Pérez, IPv6 An Internet Revolution http://long.ccaba.upc.es/long/070Related_Activities/020Documents/IPv6_An_Internet_Revolution.pdf
- [12] Brian Haberman, and George Tsirtsis. Home Networking with IPv6. http://www.ipv6forum.com/navbar/papers/Home_Networking_IPv6_2000.pdf
- [13] Wolfgang Fritsche and Florian Heissenhuber. Mobility support for the Next Generation Internet. http://www.ipv6forum.com/navbar/papers/MobileIPv6_Whitepaper.pdf
- [14] William Stallings. IPv6: The New Internet Protocol, <http://www.cs-ipv6.lancs.ac.uk/ipv6/documents/papers/stallings/>
- [15] 80211-planet. Tutorials Available at <http://www.80211/planet.com/tutorials/article.php/1577551>
- [16] Christian Bergljung. Wireless-LAN: a Complement to 3G for Wireless Access http://www.nordunet2002.dk/powerpoint/a_christian_bergljung.pdf
- [17] Matthew Gast. "802.11 Wireless Networks: The Definitive Guide. Creating and Administering Wireless Networks", April 2002.
- [18] Jochen H. Schiller. "Mobile Communications", January 2000.
- [19] Cisco Systems. "Cisco IOS NetFlow Version 9 White Paper", May 2003. http://www.cisco.com/warp/public/cc/pd/iosw/prod/lit/tflow_wp.htm
- [20] MIPL Mobile IPv6 for Linux. <http://www.mipl.mediapoli.com/>