

Section 8 – Y/602/2888

Understand and apply domestic central heating system installation and maintenance techniques



Y/602/2888 – Understand and apply domestic central heating system installation and maintenance techniques

This combination unit provides basic learning in the installation, maintenance, decommissioning and soundness testing of a basic range of wet central heating system/component types in dwellings and industrial/commercial properties (of similar size and scope to domestic dwellings). The unit covers systems in buildings up to 3 storeys in height and with systems up to a maximum of 40kW heat output and pipework up to 32mm diameter. Upon completion of the unit the learner will:

- LO1.** Know the uses of central heating systems in dwellings
- LO2.** Know the types of central heating system and their layout requirements
- LO3.** Know the site preparation techniques for central heating systems and components
- LO4.** Be able to apply site preparation techniques for central heating systems and components
- LO5.** Know the installation requirements of central heating systems and components
- LO6.** Be able to install central heating systems and components
- LO7.** Know the service and maintenance requirements of central heating systems and components
- LO8.** Be able to service and maintain central heating systems and components
- LO9.** Know the decommissioning requirements of central heating systems and components
- LO10.** Be able to decommission central heating systems and components
- LO11.** Know the inspection and soundness testing requirements of central heating systems and components
- LO12.** Be able to inspect and soundness test central heating systems and components.

Almost every home in the UK has a central heating system and, for most those homes, it is some form of wet central heating containing a boiler and radiators or underfloor heating. Over the years many different systems have been developed, designed and installed, and many of these older systems are still providing good service today, despite their lack of today's energy saving controls.

Modern systems use energy saving appliances and boilers linked with energy saving controls and components to give the best possible heating both for the end user and for the environment.

In this Unit, we will look at the layouts and types of some of the systems of the past and the modern systems that you will install on a day-to-day basis. You will see how they have developed from the basic to the sophisticated as we investigate this most difficult of subjects.

Learning Outcome 1

Know the uses of central heating systems in dwellings

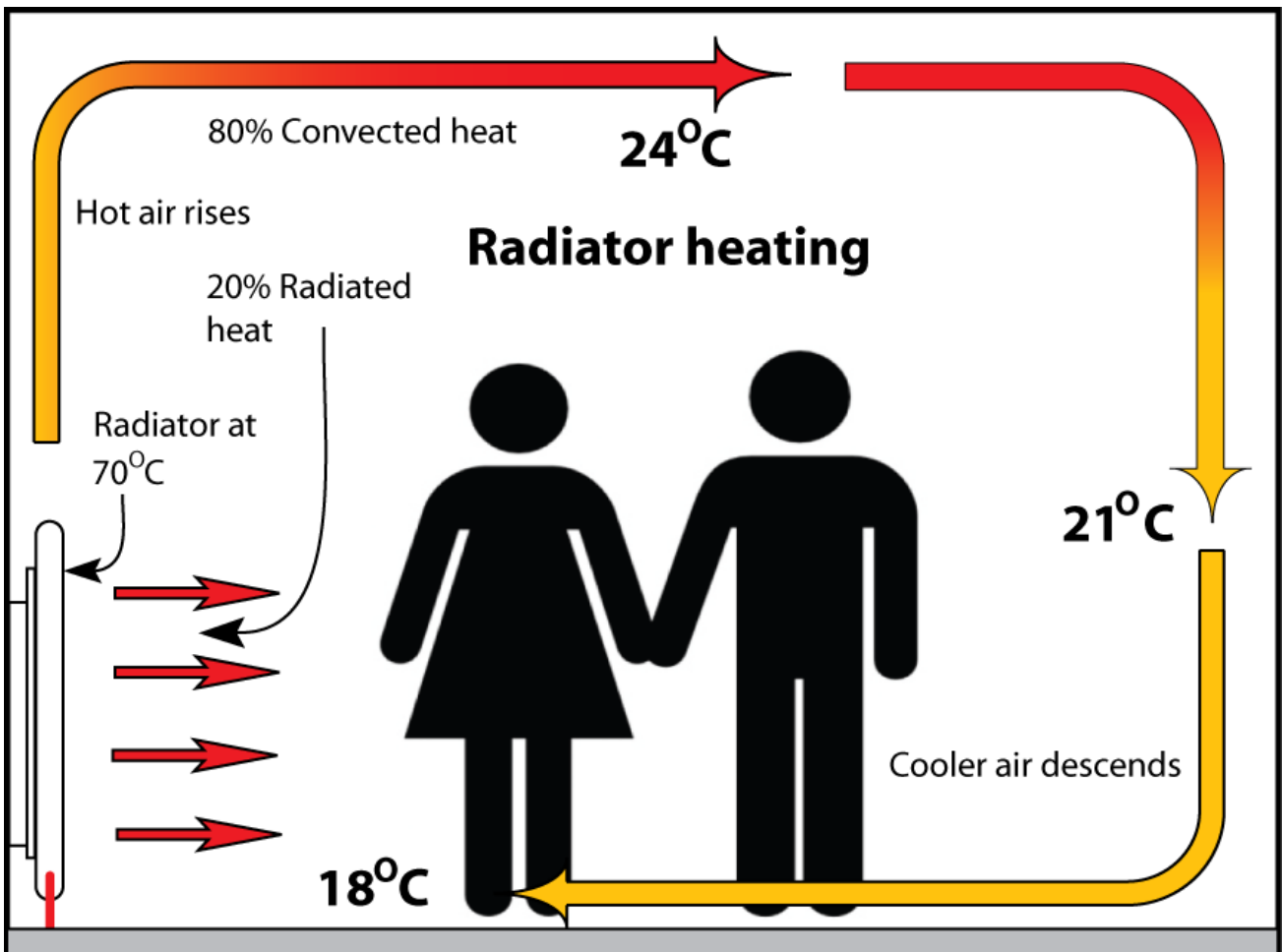

There are two Assessment Criteria in this Learning Outcome:

- AC1.1.** State the purpose of central heating systems used in dwellings.
- AC1.2.** Identify the different types of space heating systems used in dwellings

Good central heating starts with good design, the recommendations for which are set out in a series of documents, both legislative and advisory. In this first Learning Outcome, we will investigate the purpose of central heating. In other words, what makes us thermally comfortable and why and what can we do to achieve this.

AC1.1 State the purpose of central heating systems used in dwellings.

The purpose of central heating is to provide a set of conditions within a building that make us feel thermally comfortable. It's not just about heat and warmth. There are a number of different factors that must be taken into account and when these factors are in balance, then the conditions within the building make us feel not just warm, but thermally comfortable. These conditions will change with age, health, activity and the clothing we wear. They can be divided into two very distinctive groups – Physical and Personal:

Physical factors – Air condition

Humidity

Humidity is best described as the amount of moisture in the atmosphere within an environment. It is given as a percentage (%) of moisture. Ideal conditions for humans are between 40 – 60% humidity. Below 40% can make the eyes sore and the mouth and throat dry. The reason for this is the atmosphere is leeching water from the body making the body dry and hence the body's need for water in the form of thirst. Above 60% makes the atmosphere damp, clammy and uncomfortable. Even the slightest physical exertion will make the body sweat. This condition also makes the body crave water in an effort to quench thirst.

Air changes

When humans breathe, they take in air (which is 20% oxygen) and expel Carbon Dioxide (CO₂). If there is not enough oxygen in the room, then the person will begin to feel sleepy and lethargic. This is because the atmosphere is CO₂ rich. Air changes are required to remove a CO₂ rich atmosphere and replace it with Oxygen rich air. Air changes need to be taken into account when designing central heating and the number of air changes per hour worked into the heat loss calculations.

Different rooms will have different air change requirements. For example a lounge will require 2 air changes per hour but a bathroom or kitchen 3 air changes per hour. A bedroom will only require 1 air change, since the purpose of the bedroom is for sleeping.

Air temperature

The temperature of the air required for comfort will depend largely on the sex, age, health, activity and the clothing of the persons in the building. Studies have shown that women like temperatures on average 2°C higher than men. The elderly and the infirm

also prefer temperatures higher than the average person. On average, 22°C in the winter and 23°C in the summer are the optimum temperatures for human comfort.

Air velocity

The air velocity refers to the speed at which air travels through the building. If the air is travelling too quickly, the occupants will feel a draught. If the air travelling too slowly, then the air change requirements for the building will not be satisfied. The optimum velocity is 0.2 to 0.25 m/s. However a variable air velocity is much more beneficial to human comfort than a constant air velocity

Personal factors - Human

Activity within the building

The more work we do, the hotter we become and the less heat will be required in the building. In this instance the air temperature may need to be adjusted to suit the type of activity within the building. On average, 22°C in the winter and 23°C in the summer are the optimum temperatures for human comfort provided the occupants are sedentary. In other words, provided they are seated and inactive. When people begin to move, then the body temperature rises and the need for heat becomes less.

Clothing

This refers to the type of clothing worn by the occupants of the building. The more clothing is worn, then the less the air temperature will need to be. Adding and removing clothing or simply having a hot or cold drink can make a positive change in thermal comfort:

BEHAVIOUR	EFFECT	TEMP. OFFSET
Jumper/Jacket on or off	Changes Clothing by ± 0.35	$\pm 2.2^{\circ}\text{C}$
Tight fit/Loose fit clothing	Changes Clothing by ± 0.26	$\pm 1.7^{\circ}\text{C}$
Collar and tie on or off	Changes Clothing by ± 0.13	$\pm 0.8^{\circ}\text{C}$
Seated or walking around	Varies Metabolism by ± 0.4	$\pm 3.4^{\circ}\text{C}$
Stress level	Varies Metabolism by ± 0.3	$\pm 2.6^{\circ}\text{C}$
Consume cold drink	Varies Metabolism by -0.12	$+ 0.9^{\circ}\text{C}$
Consume hot drink/food	Varies Metabolism by $+0.12$	$- 0.9^{\circ}\text{C}$
Operate desk fan	Varies Velocity by $+2.0\text{m/s}$	$+ 2.8^{\circ}\text{C}$
Operate ceiling fan	Varies Velocity by $+1.0\text{m/s}$	$+ 2.2^{\circ}\text{C}$
Open window	Varies Velocity by $+0.5\text{m/s}$	$+ 1.1^{\circ}\text{C}$

Table - The effect of adaptive behaviour's on optimum comfort temperatures. Taken from BRE

What is interesting about the above table, is that it shows that drinking a cold drink makes you hotter and drinking a hot drink makes you cooler!

Age and health

This is a major factor in good heating design. The age and the health of the building's occupants have a direct effect on the temperatures that the system is designed to meet. Older and infirm people quite often feel the cold in a way that the young and abled bodied persons do not. In nursing homes and hospitals, for instance, the temperature should be a constant 23 - 24°C. this will mean significant changes in the heating

calculations and the heating system design.

So, it can be said that thermal comfort has been achieved when a balance between the body and its surroundings has been achieved. How we achieve that balance is down to personal thermal preference and good heating design.

AC1.2 Identify the different types of space heating systems used in dwellings

Full central heating

Definition – *The simultaneous heating of all spaces in a dwelling so as to maintain specified temperatures based upon calculated heat losses.*

These are systems that have been designed correctly using recognised heating data and calculation methods. They are designed to best practice conditions as recommended in the Domestic Heating Compliance Guide and installed using good quality materials, components and appliances. They are commissioned and maintained to give optimum performance and energy efficiency.

Background heating

Definition – *The simultaneous heating of all or some of the spaces in a dwelling to temperatures below those specified based upon calculated heat losses.*

This type of installation is based mainly on the cost of the materials. Smaller boilers and heat emitters only provide enough heat to take the chill from the room. Recommended air temperatures are not achieved simply because the heat emitters do not have the required output to achieve them. It is often used to reduce the risk of condensation in certain rooms. This kind of installation is no longer acceptable under **Building Regulations Document L1a – Conservation of fuel and power in new Dwellings** because of efficiency and environmental issues.

Selective heating

Definition – *The simultaneous heating of some of the spaces in a dwelling so as to maintain specified temperatures based upon calculated heat losses. Often called part house central heating.*

This heating system only heats certain parts of a building, although the heated parts still achieve the recommended temperatures based upon calculated heat losses, heat emitter sizes and pipe sizes. This system is extremely rare for domestic properties but may readily be found in some commercial buildings where certain spaces will generally be unoccupied for most of the time.

Two and one pipe systems.

One and two pipe systems refers to the type of pipework system employed to heat the building:

One pipe systems use a single circuit of pipework that runs from the boiler and back to the boiler, connecting each radiator in turn. They are inefficient and no longer

installed in domestic properties. These will be discussed later in the Unit.

Two pipe systems were developed in the early 1970's and still form the basis of all good central heating systems that are currently installed. They use two circuits of pipework – a flow circuit and a return circuit – to distribute the heated water to the heat emitters. They are more efficient than one pipe circuits and reduce the heating time of the building considerably. Again, these will be discussed later in the Unit.

Advert

COMING SOON!

from



Level 3 Gas Engineering Qualification

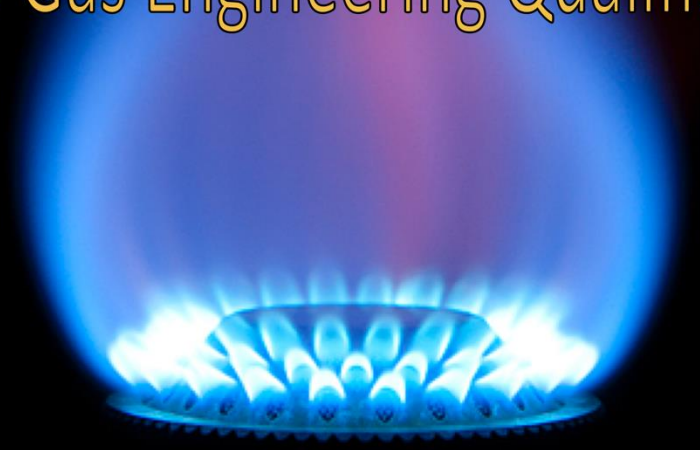

-  Find us on LinkedIn
-  Follow us at @bpec1
-  View us at flickr.com/bpec1
-  Join us at facebook.com/bpecpage
-  Watch us at youtube.com/bpec123

T: 01332 376000
F: 0845 121 1931
E: info@bpec.org.uk
W: www.bpec.org.uk
BPEC, 1-2 Mallard Way, Pride Park, Derby, DE24 8GX

Learning Outcome 2

Know the types of central heating systems and their layout requirements

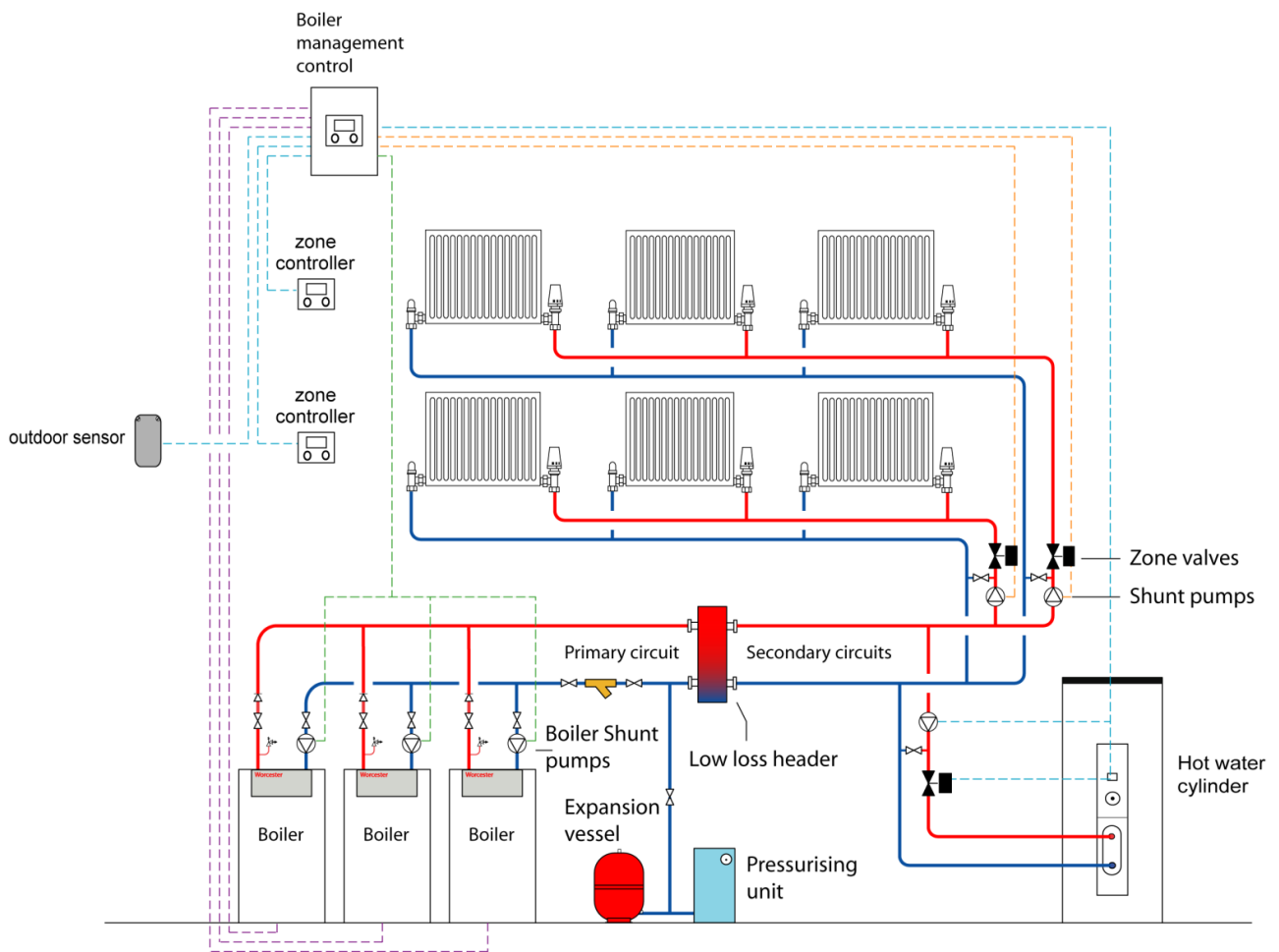

There are ten Assessment Criteria in this Learning Outcome:

- AC2.1.** Identify the working principles of central heating systems
- AC2.2.** Identify the type of central heating system from layout diagrams
- AC2.3.** State the system layout features for filling and venting systems
- AC2.4.** State the layout features for the systems that include micro and minibore pipework.
- AC2.5.** State the general operating principles of solid fired heat producing appliances
- AC2.6.** State the general operating principles of oil fired heat producing appliances
- AC2.7.** State the general operating principles of gas fired heat producing appliances
- AC2.8.** State the operating principles of heat emitters
- AC2.9.** State the operating principles of central heating control components
- AC2.10.** State the operating principles of devices used in central heating systems to minimise the build-up of sediment.

Before we investigate these systems, we will look at some of the key phrases and terms you will come across as we work through the wet central heating subject.

Phrase

Meaning

Low pressure heating

A heating system that operates at temperatures below 100°C because it includes an open vent pipe.

Open vent

The open vent prevents heating systems from exceeding 100°C and assists with accommodating the expansion of water due to the water being heated.

Sealed heating

A heating system that does not contain a vent pipe or feed and expansion system. It is filled with water from the mains cold water supply using a temporary filling loop or some other no less effective device that creates an airgap between the heating system and the water main.

Gravity

A method of heating water that uses conduction. When water is heated, it expands and loses density, the lighter, hotter water then flows upwards to the heat exchanger. When the water cools, it becomes denser and circulates back to the boiler. This continuous cycle is called gravity circulation

Microbore

A system of heating that uses very small pipe work to the radiators. Typically sizes of 8mm and 10mm pipework.

Manifold

A fitting or component that allows multiple pipe connections in one

place.

Feed and Expansion Cistern

A small, usually 10 litre capacity, cold water cistern that is connected to a low-pressure heating system for the purposes of system filling with water and to allow water to expand in to it when the water is heated.

Filling loop

A temporary connection between the mains cold water supply and the heating system for the purposes of filling and pressurisation. It should be removed after the filling, venting and pressurization tasks are completed.

AC2.1 Identify the working principles of central heating systems

AC2.2 Identify the type of central heating system from layout diagrams

Traditionally the most popular form of heating system in the UK, wet central heating systems rely on the circulation of heated water around a circuit of pipework to heat some form of heat emitter or, in the case of underfloor heating, the floors of the structure of the building itself. The heat is then transferred into the building using conduction, convection and radiation (see Scientific Principles). The heating of the water can be performed by the use of gas, oil or solid fuelled appliances or by environmentally friendly sources, such as air source and ground source heat pumps, micro co-generation sources and biomass boilers.

There are many different wet systems that have been installed over the years, and some of these are still in use today. Modern systems still use some of the theory and design that was developed many years ago but now use modern installation techniques, materials and controls to give much better use of the energy they use and the heat they generate. Heating systems, both new and old, include:

1. One pipe low pressure systems
 - a) Pumped heating with gravity hot water (semi-gravity)
2. Two pipe low pressure systems
 - a) Pumped heating with gravity hot water (semi-gravity)
 - b) C Plan systems
3. Fully pumped low pressure systems
 - a) Fully pumped, 3 port valve (mid position/diverting) (Y/W plans)
 - b) Fully pumped, 2 x two port valves (S plan)
4. Two pipe sealed systems (using system boilers or sealed system components)
 - a) Fully pumped, 3 x two port valves (S plan+)
 - b) Microbore systems

c) Systems using combination boilers

5. Underfloor heating systems.

1 One pipe low pressure systems

One pipe systems use a continuous loop of pipework that travels to and from the boiler. Each heat emitter was taken from the single loop. When they were first designed, they were purely a gravity system, working without the aid of a circulating pump, and there were many variations, such as the one pipe drop, one pipe ladder, one pipe upfeed systems.

In the late 1950s, the central heating circulating pump was developed and this greatly improved the heat-up time of gravity systems, enabling smaller pipework to be used, typically 28mm and 22mm loops with radiators installed and connected in 15mm.

In domestic dwellings, the main system used was the Pumped heating with gravity hot water (semi-gravity) system.

a) Pumped heating with gravity hot water (semi-gravity)

The diagram shows a typical domestic pumped one pipe semi gravity system. Here, the hot water storage cylinder heats up by gravity circulation, with the heating water to the radiators being pumped by a circulating pump installed on the return part of the pipework loop.

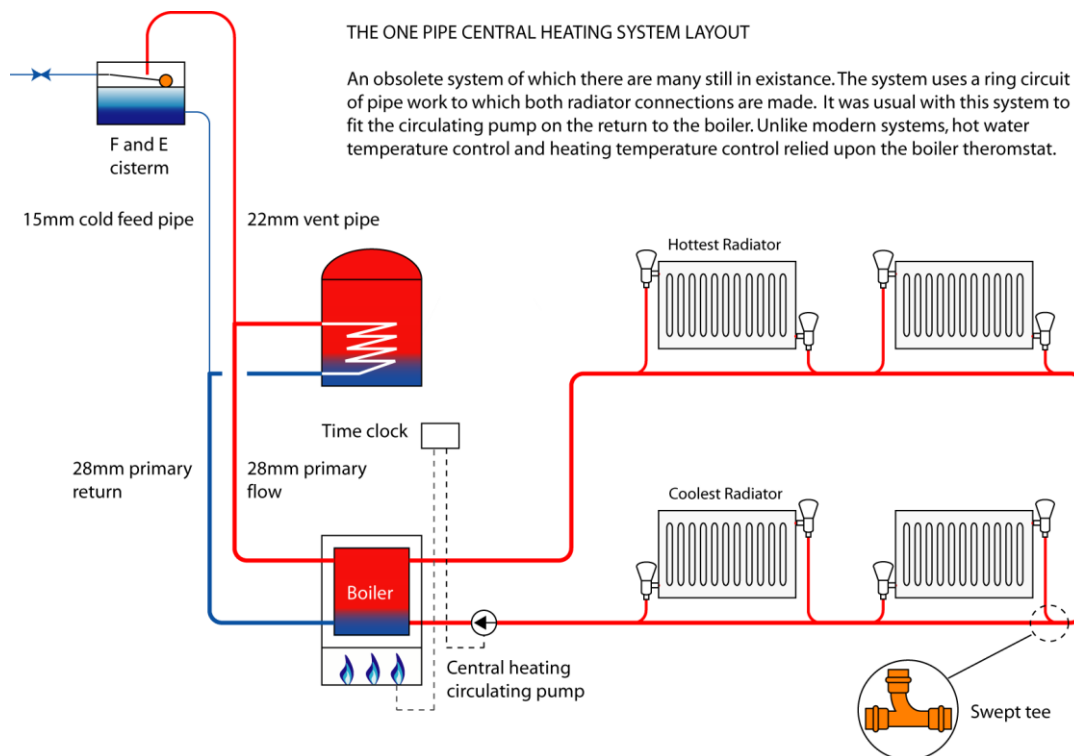

Each radiator is connected to the heating circuit that flows from the boiler and back to the boiler in a single unbroken loop of pipework. The radiators are usually connected via swept tees, as shown in the diagram,

with the flow pipe connected to the top connection on the radiator. The reason for this is that although the water in the circuit is pumped, the water is not actually pumped through the radiators. When water is circulated mechanically, it takes the least line of resistance. Radiators offer too much resistance to flow and so the water in the radiator heats up through gravity. By installing the flow at the top of the radiator, the hot water is circulated directly to the top section of the radiator, where it immediately begins to cool by a few degrees. The cooler water begins to descend through the radiator a lot more quickly than the heated water rises through it, so the radiator heats up more rapidly than if the hot water had entered at the bottom of the radiator. This creates a better gravity circulation.

A detrimental feature of this system was that each successive radiator is fed with water that is around 4°C cooler than the previous radiator. The first radiator on the system will always be the hottest, usually around 70°C, but the cooler water leaving the radiator mixes with the pipework loop, making the loop water somewhat cooler. This cooler water is then circulated through the next radiator, leaving the radiator cooler still and when mixed with the water in the loop, it cooled down further and so on, and so on. If we look at the four radiators on the diagram, the first radiator will be around 70°C but the last radiator, just before the loop enters the boiler, will be considerably cooler at around 56°C. The net effect of this is that a greater surface of heat emitter was required to heat the room. In other words, the radiators got bigger in proportion to the heat output.

Thermostatic control of both the hot water and the heating within this system was solely reliant on the boiler thermostat, which often meant that the hot water in the storage cylinder was excessively hot, especially in cold weather when the heating temperature was increased.

2 Two pipe low pressure (semi gravity) systems

Two pipe systems were a direct development of the one pipe system and gave an immediate improvement both in heat up times and temperature outputs of the heat emitters. Two pipe systems use two circuits; a flow circuit that goes from the boiler to every heat emitter and a return circuit that travels from every radiator back to the boiler. The benefit of this is that every radiator, in effect, has its own circuit to and from the boiler. This ensures that all radiators achieve similar temperatures because each radiator is supplied with water at the same temperature.

a Pumped heating with gravity hot water (semi-gravity)

With this system, the secondary water hot water storage cylinder is heated by the heat exchanger in the cylinder. The primary flow and return are heated by the boiler and the water circulated through the coil heat exchanger by gravity circulation.

The heating circuits are heated with water that is pump circulated from the boiler. The pump is installed on the flow pipe, as this gives better flow rates through the radiators, because the hotter, less dense water is easier to circulate through the system. A simple room thermostat helps to control the room temperatures by switching the pump off when the thermostat is satisfied. It is used in conjunction with thermostatic radiator valves. The main disadvantage with the two pipe system is the lack of secondary hot water

temperature control, as there is no thermostat fitted on to the primary flow and return. This means that the temperature of the secondary hot water in the cylinder will be dictated by the temperature of the heating circuit. Look at the diagrams below:

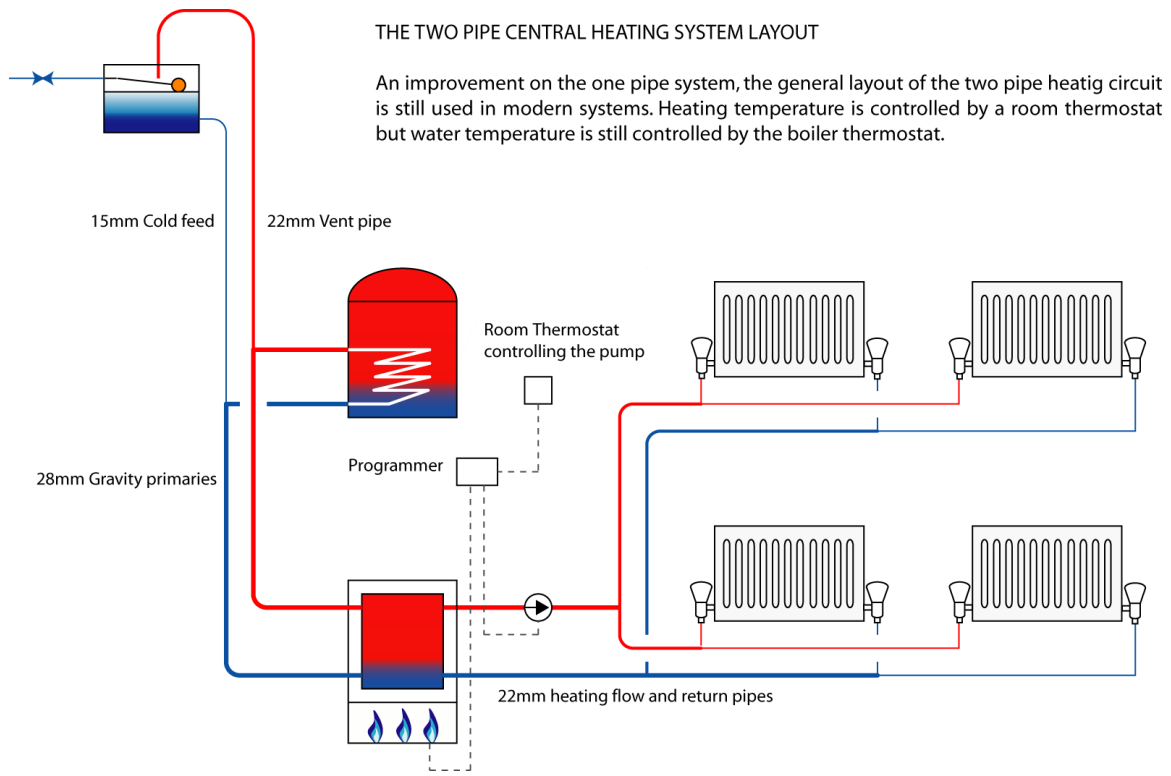

Pumped heating with gravity hot water (semi-gravity) (top) and heat sink radiator for use with a solid fuel boiler (bottom)

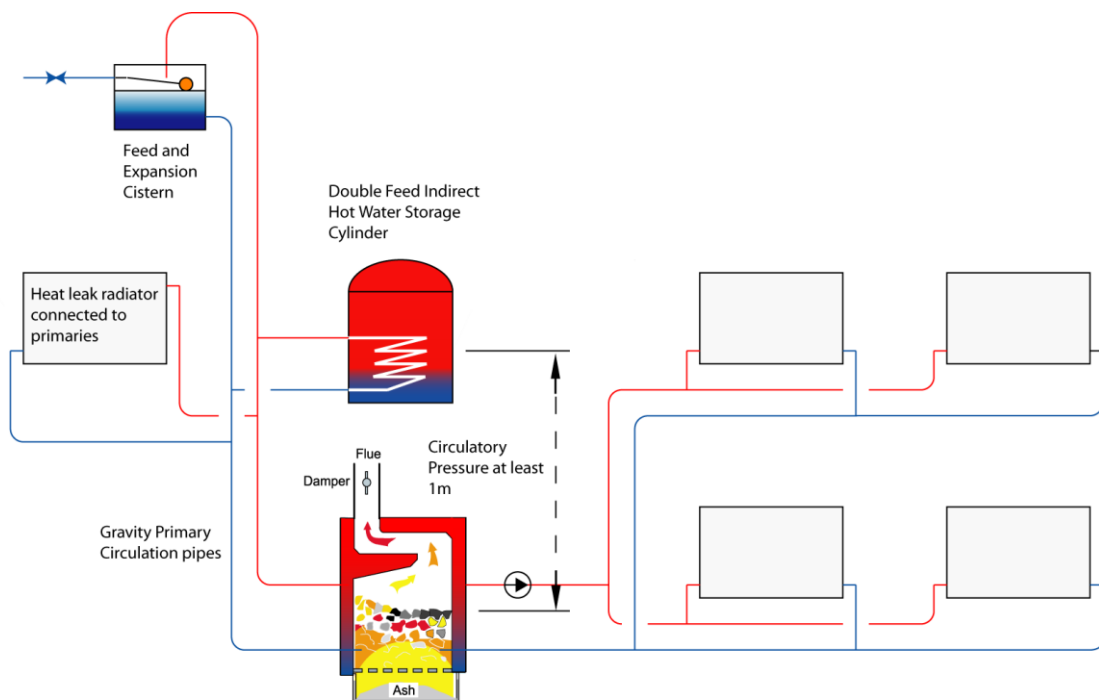

Solid fuel appliances are not as controllable as gas or oil. This makes them exceptionally difficult when it comes to heat control because as long as there is fire in the boiler, heat will be generated. The circulation of water by gravity relies on the fact that heat rises and cool descends. In gravity systems this is achieved by the flow pipe being hotter than the return pipe. Where solid fuel appliances are concerned, the inability to effectively control the heat output from the fuel means that, eventually the return pipe will be almost as hot as the flow. At this point, gravity circulation will cease and the system will boil, sometimes with disastrous consequences. The idea of the heat leak radiator is to allow any excess heat to disperse to the surrounding atmosphere and this will ensure at least a minimum amount of continued gravity circulation through the system. A heat leak radiator MUST be controlled by LOCKSHIELD-TYPE radiator valves at either end of the radiator to prevent tampering.

The basic layout for a system using a solid fuel boiler is very similar to other semi-gravity type systems. There are however, subtle differences:

- Solid fuel appliances use mechanical temperature control to control the heat output from the boiler. Any electrical temperature controls will need to be added to the pipework.
- It is essential that a heat sink loop is installed with solid fuel systems and that only vented systems are used. Sealed system components MUST NOT be installed on solid fuel heating systems.

For this reason, solid fuel systems are usually fitted with the following controls:

- A room thermostat and a single channel time clock to control the circulating pump.
- A pipe thermostat installed on the gravity flow set to 45°C. The pump must not run if the temperature is below this. The pipe thermostat prevents heat from the stored hot water in the cylinder from being 'dumped' around the heat sink if the heat sink cools down. This is a major cause of condensation and corrosion within the system.
- A second pipe thermostat, this time set to 90°C to automatically energise the pump if the temperature exceeds 90°C to dissipate the heat through the heating system. This must be set to override all other controls.
- The system must include a heat leak circuit/radiator fitted with lockshield valves to prevent tampering.
- An 'anti-gravity' valve can be included on the upstairs heating circuit to prevent unwanted gravity heating circulation, especially during the summer months.
- A large capacity hot water storage vessel.

b C Plan (semi gravity) systems

The Honeywell C Plan system is almost identical to the previous system. The only difference here is the inclusion of a two-port motorised zone valve on the primary flow into the cylinder. This is linked to a cylinder thermostat placed on the hot water storage cylinder about ¼ of the way up from the bottom of the cylinder to control the secondary hot water temperature. The system is now fully temperature controlled. The C Plan is recognised as a possible upgrade to the two pipe (semi gravity) system for existing systems only by Approved Document L of the Building Regulations 2013 (with 2016 amendments).

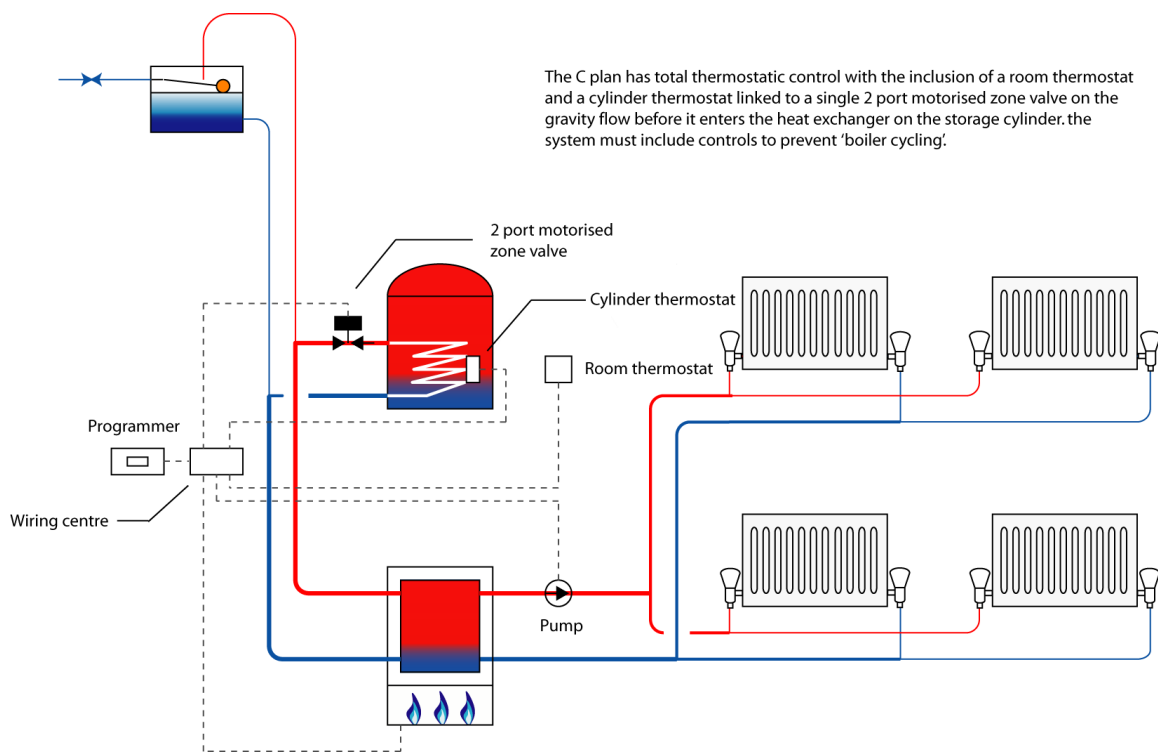
*C Plan system*

3. Fully pumped systems

As Domestic Heating systems developed, the need to eliminate gravity circulation became apparent. Gravity circulation is very wasteful in terms of heat energy and fuel and so, by the inclusion of a motorised valve or a series of motorised valves, heating systems became fully pumped. In other words, the circulating pump now pumped the water around the heat exchanger/coil in the storage cylinder, as well as the heating system itself. Temperature control was maintained by using a room thermostat to control the heating and a cylinder thermostat to control the secondary hot water. Three initial systems were developed:

- The Honeywell Y Plan using a three-port motorised mid-position valve,
- The Honeywell W Plan using a three-port motorised diverter valve, and;
- The Honeywell S Plan using two, two-port motorised zone valves

Fully pumped systems give a greater choice of system design, especially when positioning components such as the hot water storage cylinder. No longer was it necessary to have the cylinder higher than the boiler because gravity circulation had been eliminated. Other benefits are greater choice of boiler position and quicker hot water heating times. These are just a selection of the benefits of the fully pumped system.

a) The Honeywell Y Plan using a three-port motorised mid-position valve

The Y Plan uses a three-port mid-position motorised valve to control the flow of water from the boiler. The valve reacts to the demands of the system. If both heating and hot water are needed, the valve enters a mid-position allowing water to flow around both the heating and hot water circuits. If heating only is required,



3-port mid-position valve

the valve swings to close off the hot water port (Port B on the valve) to allow water to flow around the heating system only. If hot water only is required, then the valve swings to close off the heating port (Port A on the valve). When both hot water and heating are satisfied, the system will shut down completely until heat is required to either of the circuits and the valve returns to the mid-position. Water temperatures are controlled by the room thermostat and the cylinder thermostat, with individual room temperatures controlled by thermostatic radiator valves (TRVs). A system by-pass is fitted to allow water circulation through the boiler to keep the boiler below its high energy cut-out temperature (around 85°C), as this would result in the boiler overheating and the boiler 'locking out'

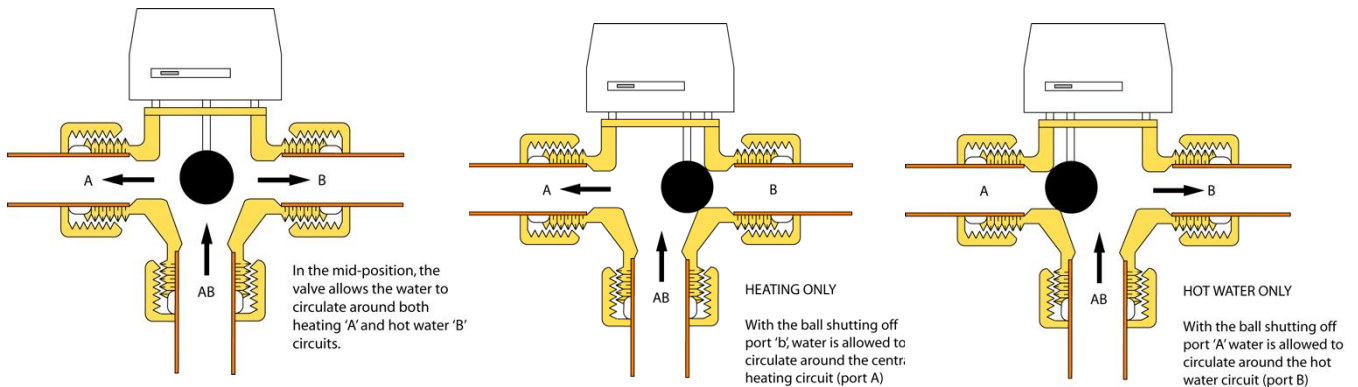

preventing the system from operating

The various positions of the mid-position valve

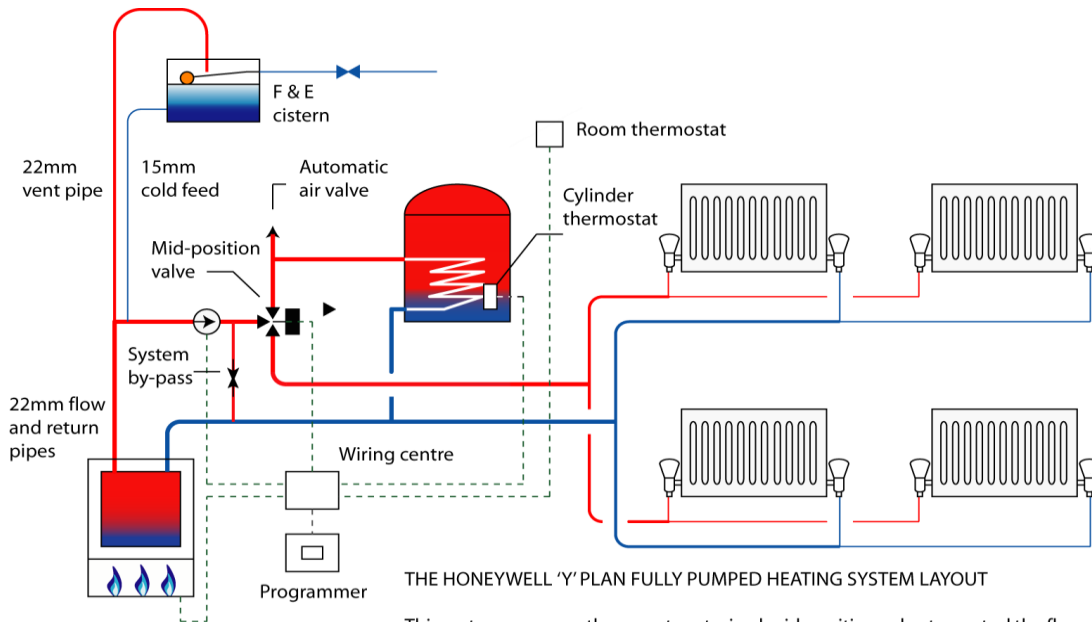

This system uses one, three port motorised mid-position valve to control the flow of water to the central heating circuit and the hot water circuit. It is controlled by a cylinder thermostat and a room thermostat. Individual thermostatic radiator valves (TRV's) independently control the temperature of each room.

b) The Honeywell W Plan using a three-port motorised diverter valve

The W Plan system uses a three-port diverter valve. The three-port valve can either open the heating circuit

or the hot water circuit but not both at the same time. One circuit is closed when the other circuit is open. It is designed to give priority to the hot water circuit, which means if both hot water and heating circuits are calling for heat, the heating circuit will not be opened until the hot water circuit is satisfied and up to the required temperature. This system is not recommended where high hot water demand is likely as it could lead to the space temperature dropping below the normal comfort levels. The system layout is identical to the Y Plan system.

c) The Honeywell S Plan system using two, two-port motorised zone valves

The S Plan system uses two, two-port motorised zone valves to independently control both the heating and hot water circuits. The room thermostat operates the heating zone valve and the cylinder thermostat operates the hot water zone valve. A system by-pass is installed in case the system needs to circulate water through the boiler to maintain the system temperature below the high energy cut-out temperature. TRVs maintain individual room temperatures.



2-port motorised zone valve

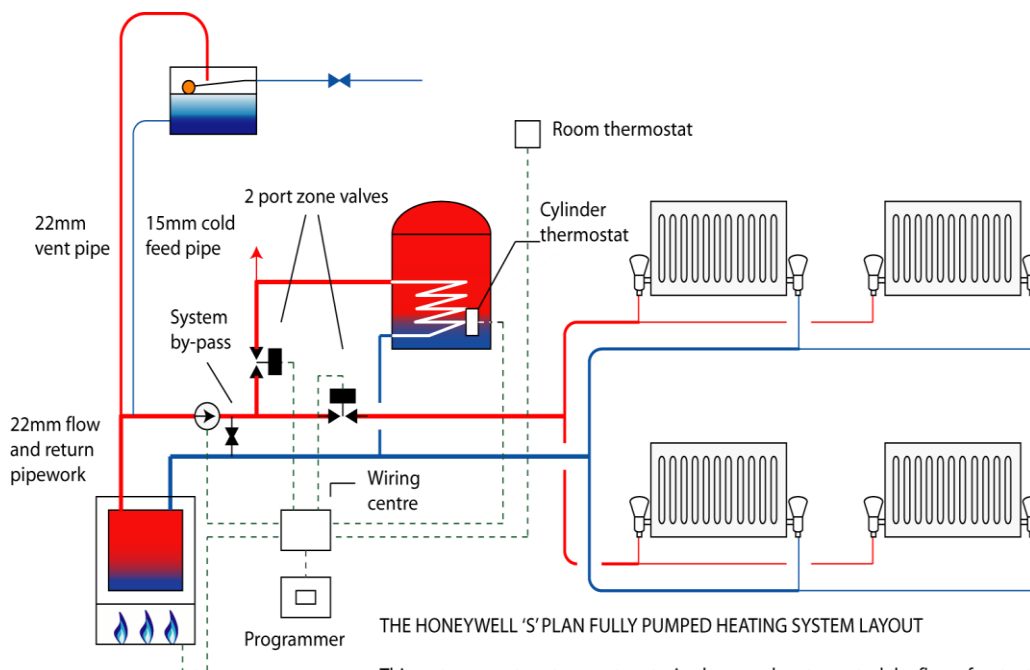

This system uses two, two port motorised zone valves to control the flow of water to the central heating circuit and the hot water circuit. They are controlled by a cylinder thermostat and a room thermostat. Individual thermostatic radiator valves (TRV's) independently control the temperature of each room.

The next development – sealed, fully pumped systems

In the late 1990s, Domestic Heating systems underwent another design change but still based on the two pipe system. Boilers became smaller and more efficient, and feed and expansion cisterns, with the introduction of the expansion vessel, became obsolete overnight. No longer was a second (feed and expansion) cistern needed in the roof space. Systems could be filled direct from the mains cold water supply

through a temporary filling loop. Gone, too, was the open vent pipe that kept the system at atmospheric pressure and safeguarded against the boiler heating the water to excessive, potentially boiling, temperatures. These new systems operated at pressures above atmospheric pressures.

They became known as 'Sealed Heating Systems'.

What is a Sealed Heating System?

A sealed heating system is a system that does not contain an open vent pipe and is, in effect, sealed off from the atmosphere. It does not have a Feed and Expansion cistern to fill the system or take up the expansion of the water when it is heated. Instead, it contains an expansion vessel to accommodate the expansion of water, a pressure/expansion relief valve to relieve excessive pressure created by expansion vessel failure and temporary filling loop to fill the system directly from the mains cold water supply. It is called 'temporary' because once the heating system is full, the filling loop MUST be disconnected to create an air gap between the water main and the heating system. This is because the water in a domestic heating system could contain chemicals to prevent corrosion, called inhibitors. The Water Supply (water fittings) Regulations 1999 classify the water contained in a central heating as fluid category 3. Water from the water main is classified as fluid category 1. The filling loop, in effect, creates a cross connection between water at fluid category 1 and water at fluid category 3, which, under the Water Regulations is not allowed without protection against back pressure or back syphonage. Because of this, the filling loop arrangement must also include an EC/ED back flow prevention device, better known as a double check valve.

Heating the water that is around 1 bar pressure gives benefits that were not present in older systems:

- 1 Air infiltration through the open vent pipe is eliminated.
- 2 Higher water pressure means better flow rate through the system.
- 3 Higher temperatures can be used if required.
- 4 Less pipework required
- 5 No need for pipework in the roof space
- 6 Systems can be fitted in flats and apartments where installing an F&E cistern at high level is problematic.

Initially, the sealed system components were installed externally to the boiler, the expansion vessel and filling loop being fitted to the return pipework, close to the boiler. Later, system boilers were designed where all the necessary components were installed within the boiler casing.

3 Two pipe sealed systems (using system boilers or sealed system components)

a) Fully pumped, 2 x two port valves (S Plan) system using external sealed system components

The S Plan sealed system layout is almost the same as its low-pressure version. The main difference is the absence of a Feed and Expansion cistern, cold feed and open vent pipes. These are replaced by a temporary filling loop, expansion vessel, pressure relief/expansion valve and a pressure gauge to monitor the system pressure. The system cold pressure is 1 bar. This will rise to around 1.5 bar when the system is hot.

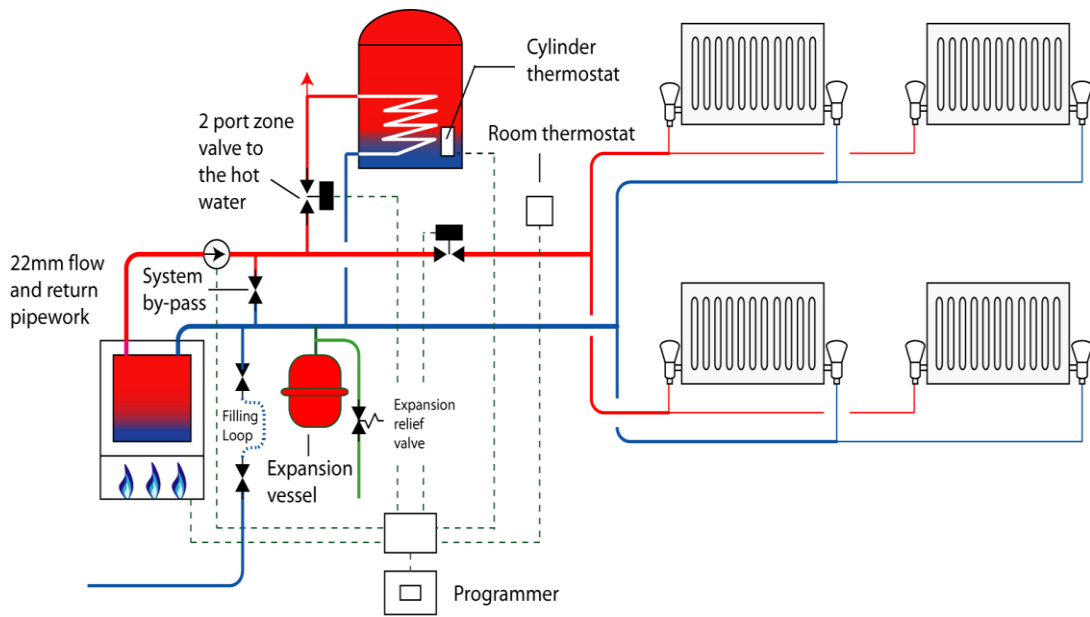

THE HONEYWELL 'S' PLAN SEALED SYSTEM FULLY PUMPED HEATING SYSTEM LAYOUT

This system uses two, two port motorised zone valves to control the flow of water to the upstairs and downstairs heating circuits and the hot water circuit. They are controlled by a cylinder thermostat and room thermostat. Individual thermostatic radiator valves (TRV's) independently control the temperature of each room.

b) Fully pumped, 3 x two port valves (S Plan Plus) system using a sealed system boiler

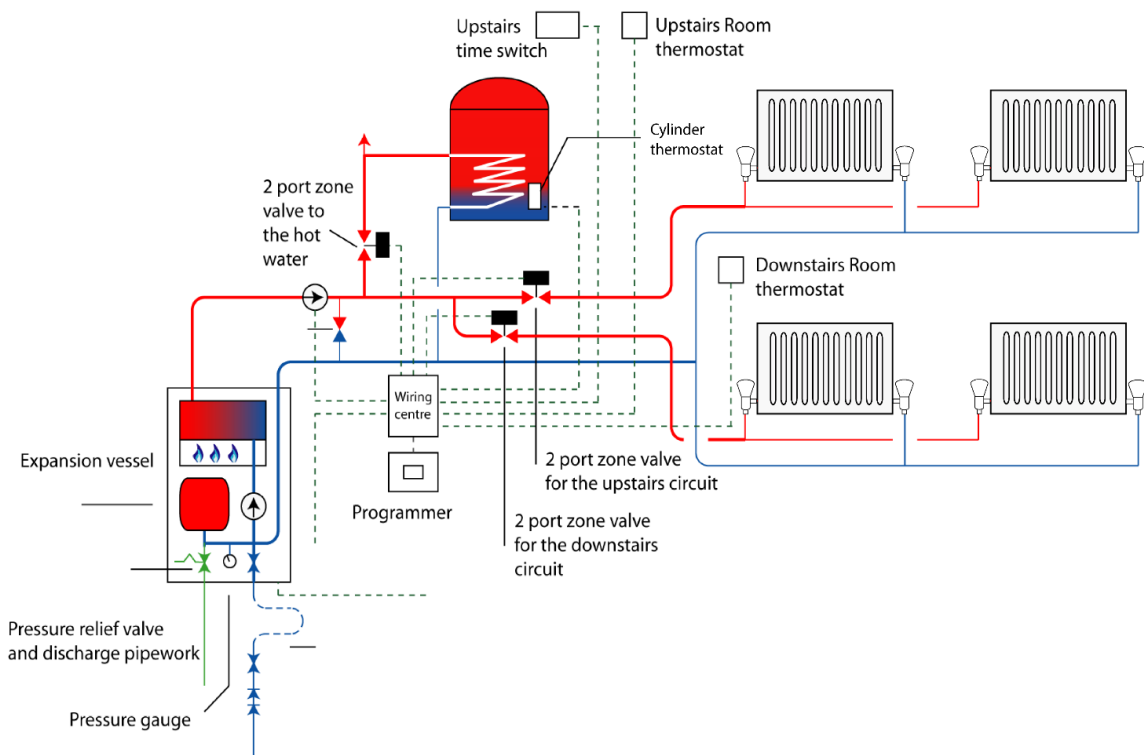

The S Plan Plus with sealed system boiler

The S Plan Plus system was designed as a result of a change in the Building Regulations Approved Document L1, which states that all dwellings must be zoned between the living space and the sleeping space in a dwelling to give individual time and temperature control across these zones. Here, the upstairs heating circuit

can be individually controlled from the downstairs living space by the inclusion of a third 2-port zone valve on the upstairs circuit. The third motorised valve is controlled by its own room thermostat and time control/programmer. The temperature of the individual rooms are controlled by programmable thermostatic radiator valves.

The drawing shows an S Plan Plus system with a sealed heating system boiler, where all components such as the expansion vessel, filling loop and pump are factory installed inside the boiler casing. This has the effect of simplifying the installation and uses less pipework.

Modern boilers must be the energy saving condensing type boiler, which has been designed to extract as much of the generated heat out of the combustion of gas and oil as possible.

c) Heating systems incorporating a combination (combi) boiler

These are probably the easiest of all heating systems in terms of design and installation. Heating systems that incorporate a combination boiler simply require flow and return pipework to and from the boiler. The flow pipe from the boiler must be separated into two separate systems using two, two-port motorised zone valves, one for the living space circuit and one for the sleeping space circuit. These should be separately controlled by individual time clocks/programmers and room thermostats. A circuit to the hot water coil/heat exchanger is not required in this case, since combination boilers use an instantaneous method of hot water supply.

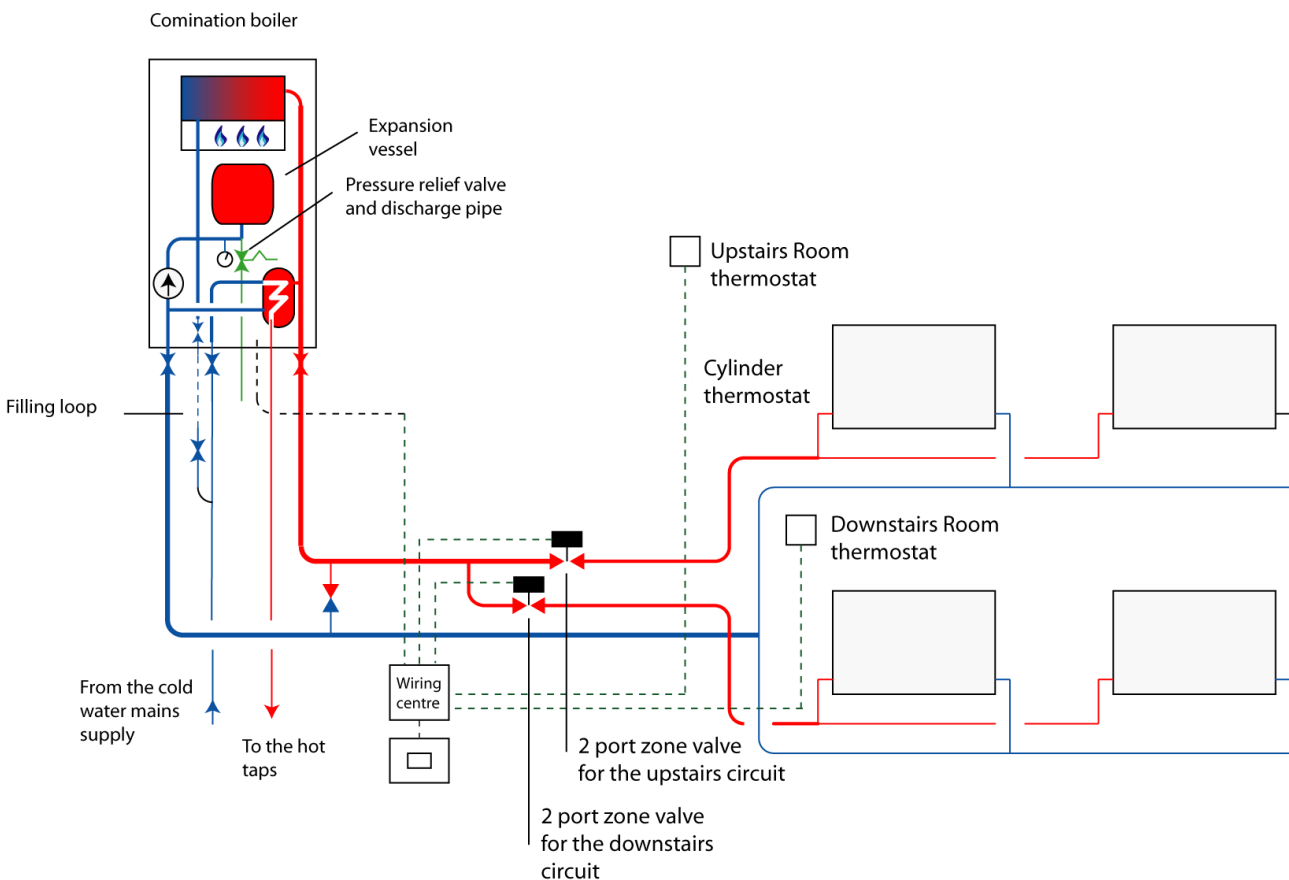

Heating system with combination boiler

AC2.3 State the system layout features for filling and venting systems

The filling and venting requirements for open vented and sealed heating systems are very different. It is important that we know how to fill these systems correctly and how to avoid common filling problems, such as air locks, which can be difficult to clear.

Trapped air is one of the biggest problems in central heating systems. It can cause pump cavitation, leading to pump failure, excessive system noise and system corrosion.

Open Vented Systems

Feed and expansion cistern position

The Feed and Expansion cistern (F&E Cistern) has three roles to play:

- It feeds the heating system with water during filling.
- It allows water to expand into it when the water is heated (some expansion also takes place up the open vent pipe). Water, when heated, expands by 4%. This expansion needs to be accommodated within the system otherwise the system may become over-pressurised raising the temperature of the boiling point of the water. The expansion takes place up the cold feed and back into the F&E cistern, raising the water level inside the cistern. Once the system cools, then the water contracts and the water level in the cistern returns to normal.
- It provides a static head to the system. In other words, it gives the systems a head of pressure i.e. 3m head = 0.3bar pressure.

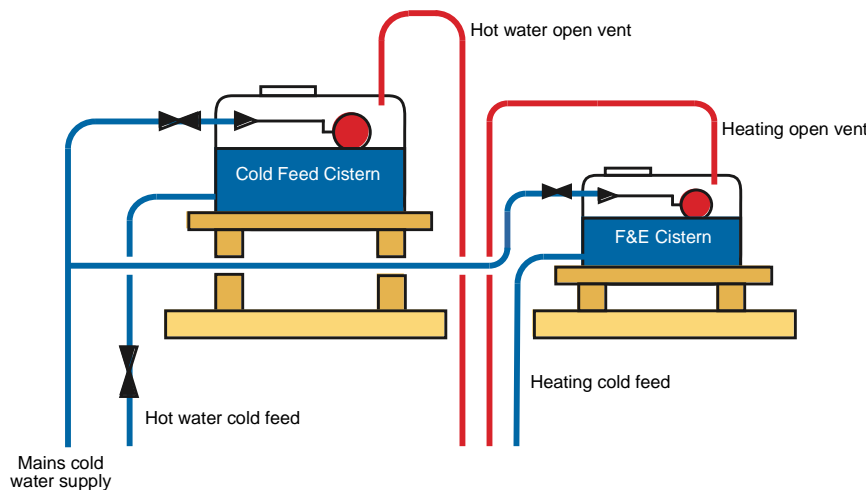

Position of the F&E cistern

The F&E cistern should be ideally placed in the roof space either on the same level or lower than any domestic cold water feed cistern or cold water storage cistern. The reason for this is because should a problem develop with the heat exchanger/coil in the hot water storage cylinder, water will pass through to the heating system raising the water level in the F&E cistern, causing the overflow to run.

This will safeguard against dirty heating water entering the domestic hot water system. There MUST be at least 1.5m head of pressure between the F&E cistern and the central heating circulating pump.

Pump position and Cold feed and open vent pipe connections

In fully pumped, open vented systems, the pump must be positioned on the flow pipe from the boiler with the cold feed and the open vent pipe installed on the suction (-) side of the pump. Take a look at the drawing below:

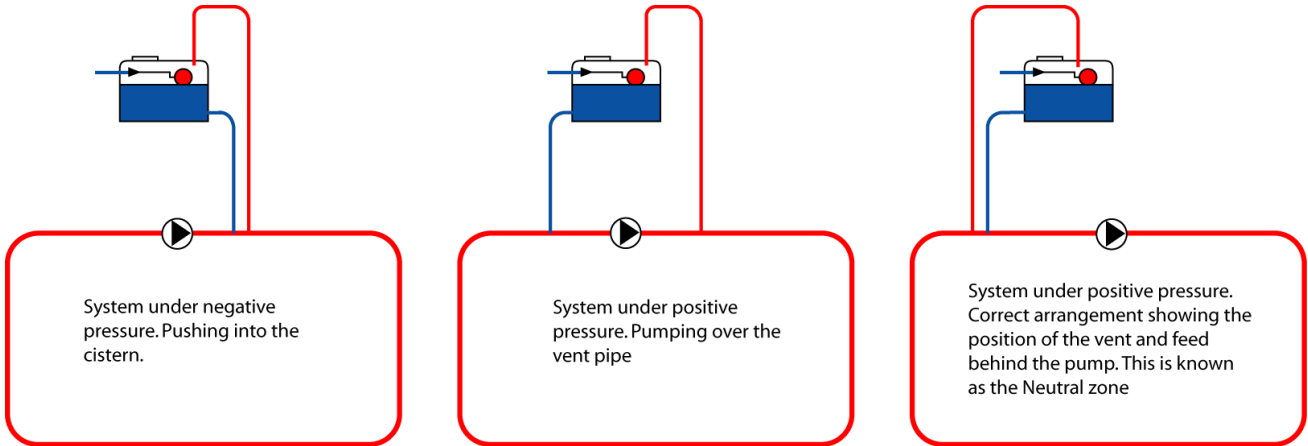

Left hand drawing – this shows the system under negative pressure. Activating the pump in this configuration would literally push water back up the cold feed and over the vent pipe. Circulation around the heat emitters would be almost impossible.

Middle drawing – here the heating feed and the heating vent pipe are installed either side of the pump. This would circulate water to and from the F&E cistern causing aeration of the water, which could lead to system corrosion. Circulation through the heat emitters would not occur.

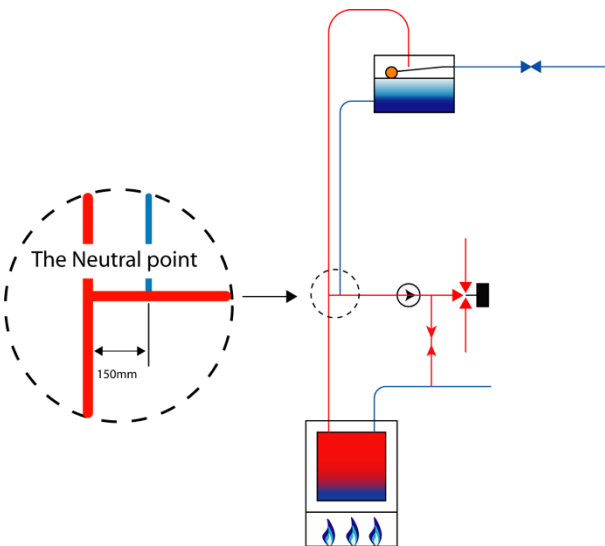

Right hand drawing – in this drawing, the cold feed and the open vent are positioned correctly on the suction side of the pump. Because both cold feed and open vent are positioned in the same place, the suction pressure on the cold feed and the open vent is equal. This means that a state of equilibrium occurs and the connections create a neutral point (see the drawing left). For the neutral point to remain in balance, the distance between the open vent and the cold feed should be no more than 150mm.

An easy way to remember the order is:

Vent, Cold feed, Pump = VCP = Very Correct Position.

The neutral zone

Methods of releasing air from the system

Where heating systems contain motorised zone valves, the valves must be open manually to ensure that the water reaches all parts of the system.

Air is released from open vented heating systems as the system fills. To prevent air locks within the pipe work, it is advisable to release the air from the furthest and lowest radiator first, working back towards the boiler

until all downstairs radiators are full. Then, progress to the upstairs furthest radiator and work back to the boiler once more



Air release key

Air is released from all of the radiators and pipework via air release valves positioned in one of the top radiator connections. A special radiator air release key is used and this is shown in the image left. Do not be tempted to remove the small air release plug from the air release valve. The air release valve should be open enough so that the escaping air can be heard. It is advisable to have a dry cloth handy to wipe up any water that escapes from the valve

Automatic air valves (AAVs) are also used to remove air in heating systems. These are usually positioned at high points in the pipework where trapped air may present a problem.

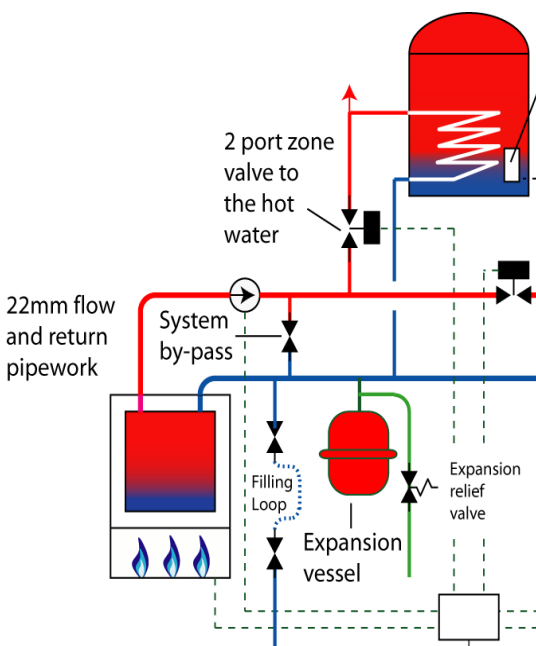

Sealed system components

Sealed systems

Sealed systems are filled with water directly from the water undertakers cold water mains supply via a temporary filling loop. They do not contain a Feed and Expansion Cistern. There are certain components of a sealed system that are unique to the system.

Expansion vessel position

The expansion vessel contains a neoprene rubber diaphragm. One side of the diaphragm is full of air and the other side, which is connected to the heating system, contains the heating system water. The expansion vessel plays a vital role in sealed heating systems.

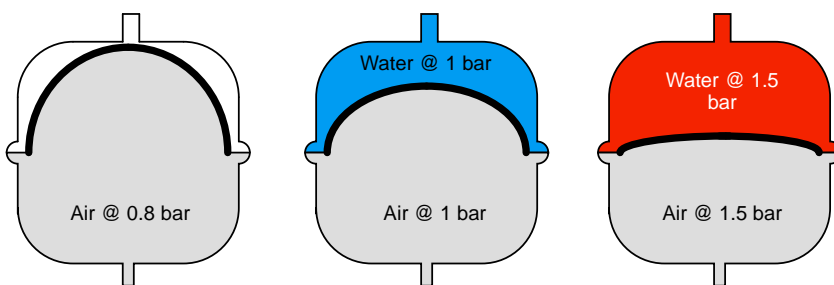

The operation of the expansion vessel

As we have already seen, when water is heated, it expands by 4%. In sealed heating systems that are already subjected to pressurised water, the expansion vessel accommodates the expanded water preventing over-pressurisation of the system. The expansion vessel should be positioned on the return pipework as this is around 20°C cooler than the flow pipework. If this is not

possible, expansion vessels can be positioned on the flow pipe but they must be connected on the suction side of the pump so that the pump does not artificially raise the pressure causing activation of the pressure relief valve.

Pressure gauge, pressure relief valve and filling loop position

The filling loop – should be positioned on the heating return pipe. Once the system is full and has been vented, the filling loop **MUST** be disconnected to comply with the Water Supply (water fittings) Regulations 1999. Filling loops must contain a Type EC Verifiable Double Check Valve to protect the water undertakers cold water main against backflow.

The pressure gauge – this shows the pressure within the system. It should also be installed on the heating return pipe, close to the expansion vessel.

The pressure relief valve – This component (also known as the expansion relief valve) should be installed close to the expansion vessel. It is a spring operated valve that provides a safety release of water and pressure should the expansion vessel malfunction. Most pressure relief valves are set to operate at 3 – 3.5bar.



Pump position

Positioning the pump on sealed systems is not as critical as for the open vented system. The lack of open vent on the system means that there is little chance of pulling air into the system. In general, pumps should be placed on the flow pipe as shown in the diagram above, pulling the heated water from the boiler. In most instances, sealed system boilers, where the pump is included inside the casing, place the pump on the return pipe, pulling the return water back to the boiler.

Methods of releasing air from the system

Air is released in the same manner and order as previously stated. It should be remembered that sealed systems are filled via a filling loop. The system should be filled initially to 1 bar pressure and the filling loop turned off. Fill each radiator until the pressure drops and turn on the filling loop and refill to 1bar. Turn off the filling loop and continue to fill the system. **DO NOT** leave the filling loop turned on whilst filling the system with water. It will fill with water far quicker than the air can be released. It **MUST** be filled in stages. Once the system is full of water, the final cold pressure should be no higher than 1 bar. This will rise to around 1.5 bar when the system is hot. Always remember to remove the filling loop.

AC2.4 State the layout features for the systems that include micro and

minibore pipework.



Microbore systems

Microbore systems are a two pipe heating system that uses very small diameter pipework, usually 8mm or 10mm piping, to feed the heat emitters. The microbore pipework is connected to a manifold, which is installed on the main flow and return pipes. A manifold is a special fitting that allows multiple connections to a single, larger pipe. They

Microbore manifolds

are usually sited centrally in the property to equalise the length of run to each radiator. Two flow and two return manifolds are also required, one flow/return manifold pair to supply the living space and one flow/return manifold pair to supply the sleeping space, so that the system may be zoned in accordance with the Building Regulations Document L1A. The pipework loops to each radiator should not be longer than 15m combined (7.5m flow, 7.5m return).

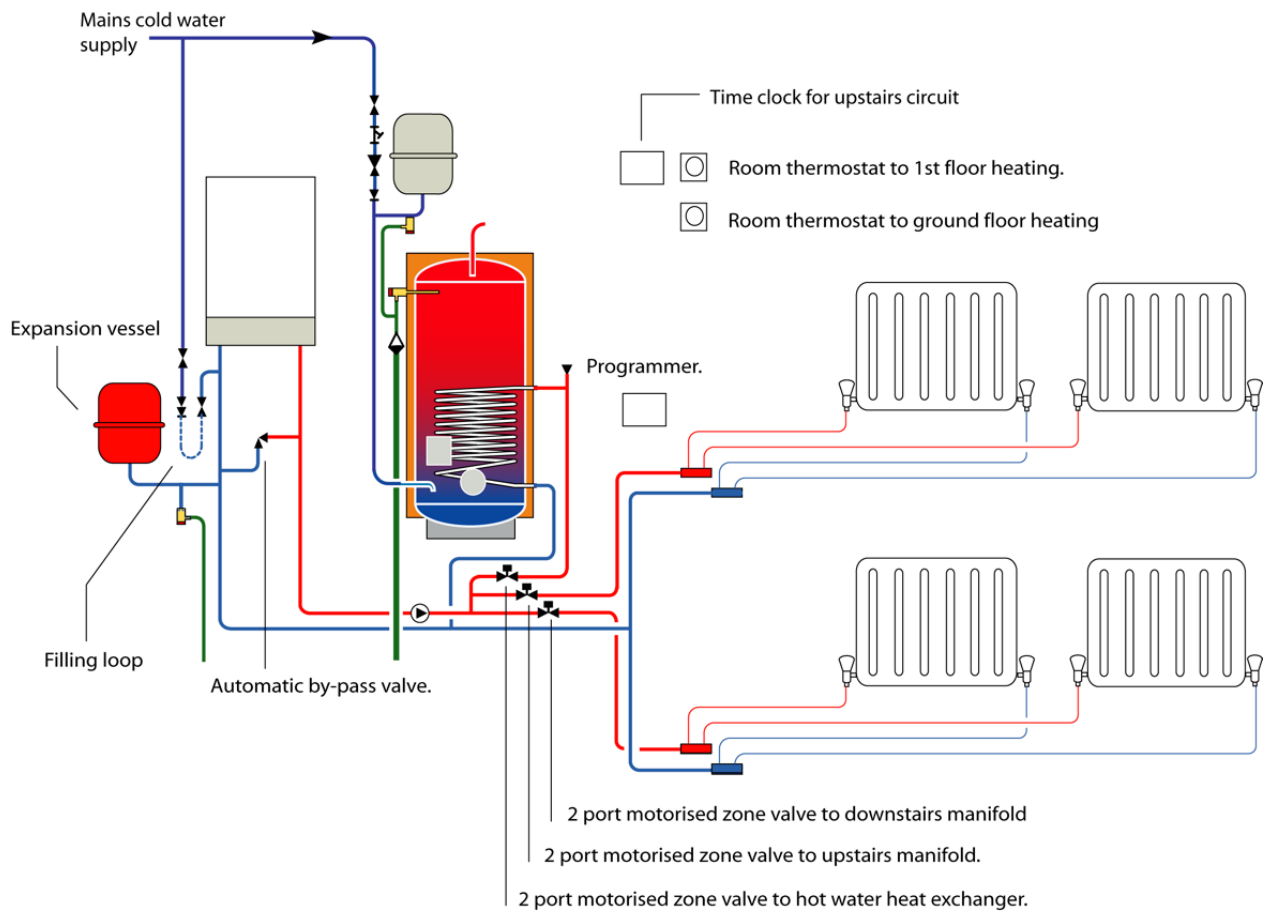

The S Plan Plus microbore system with external sealed heating system components

AC2.5 State the general operating principles of solid fuel fired heat producing appliances

Solid fuel is still used as a heating fuel in some remote areas where there is no access to a piped gas supply. There are several forms of solid fuel, including:

- Coal – high carbon, high sulphur content
- Coke – smokeless, high carbon content
- Anthracite – high calorific value, high carbon content
- Biomass wood chips and pellets – carbon neutral fuel

Each of these fuels require specific solid fuel appliances. The most common solid fuel appliances are:

- Open fires with a high output back boiler
- Room heaters
- Cookers (Aga type)
- Independent boilers

High output back boiler

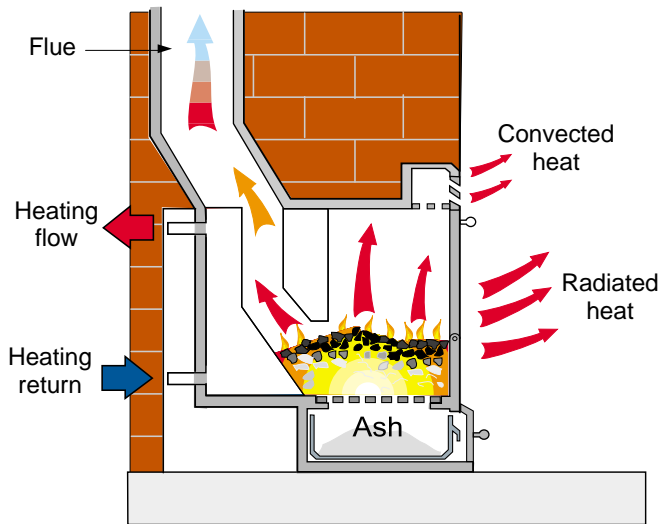

A high output back boiler

High output back boilers are installed behind a solid fuel fire. Many of this type of boiler have glass fronted doors. The heat is distributed into the room by convection and radiation. The back boiler supplies hot water to the heating system and hot water storage cylinder.

The heat is controlled via a damper in the open flue or chimney. The damper controls the flue up-draught (air flow). The less up-draught, the less heat will be produced by the fire bed.

Typical outputs to the heating/hot water range from 6.8 to 10 kW. Radiated heat output is around 2.6kW.



A room heater

Room heaters and log burners

A solid fuel room heater provides heat into the room where it is fitted. Some models may provide hot water via a small hot water heat exchanger. They are not suitable for providing central heating.

Cookers (Aga type)

Solid fuel cookers have been around for many years. Solid fuel cookers rely on the fact that the fire is permanently lit. The boiler is extremely well insulated preventing excessive heat escaping into the kitchen.

The hot plates are covered with insulated cast iron covers that lift up when cooking is required. Many models provide hot water and heating as well as cooking.

Solid fuel cookers are manufactured to burn a variety of solid fuels including logs and all have easy-to-clean ash pans.

Oil fired versions are also available.

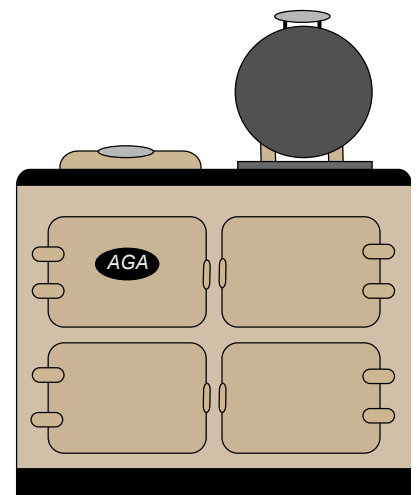

An Aga cooker

Independent boilers

Solid fuel, open flued, freestanding boilers are available in many styles and sizes to suit large and small

heating systems alike. There are two basic types:

Gravity feed solid fuel boilers

Often called 'hopper feed' boilers, gravity feed boilers incorporate a large fuel storage box, called a hopper, positioned above the firebox. Fuel is automatically fed through to the fire bed without the need for constant stoking. The hopper can hold 2 to 3 days' worth of fuel. An in-built fan, which is thermostatically controlled, supplies combustion air for a rapid response if there is an increase in heat demand. The main danger with hopper fed boilers is the risk that the hopper, being situated so close to the combustion chamber, could catch fire and this requires careful monitoring and the fire bed needs to be regulated with care.

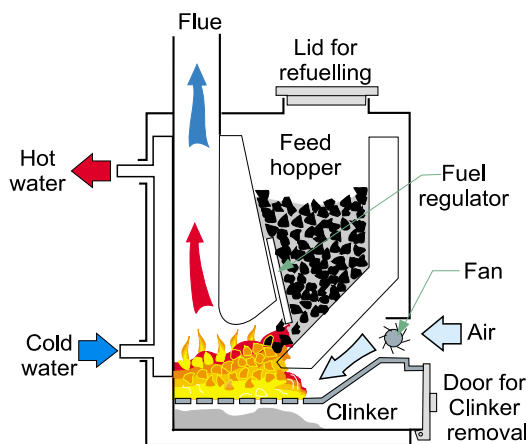

A gravity feed boiler

Batch feed boilers

These are hand fired boilers that require manual stoking.

Although they require more refuelling than gravity feed boilers, they are often cheaper to run and will continue to operate without an electricity supply.

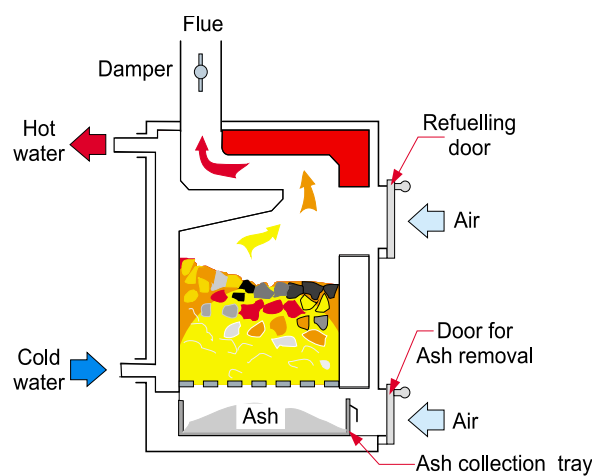

A batch feed boiler

AC2.6 State the general operating principles of oil fired heat producing appliances

Most oil fired appliances for domestic heating systems use C2 Grade 28 second viscosity oil. It is more widely known as kerosene. It is often used in rural areas where access to a mains gas supply is difficult. There are two types of oil burning appliances:

- Those that use the pressure jet (atomising) burner.
- Those that use the vapourising burner.

The principles of the pressure jet (atomising) burner

Pressure jet burners work on the principle that the oil must be atomised and mixed with oxygen before the

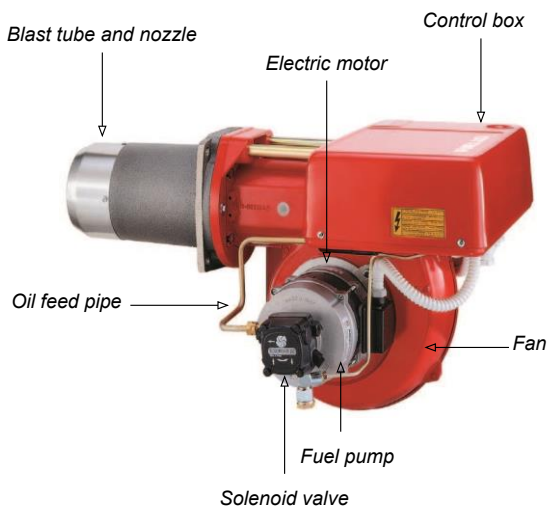

oil will ignite. Atomising burners have an electrical fan to introduce the air and a fuel pump, to push the oil though to the nozzle. The fuel flow is controlled by an electrically operated solenoid valve. At the nozzle, the fuel is atomised in to an aerosol mist and mixed with the air where it is then ignited by a spark ignitor. Once lit, the burner will continue to burn as long as there is fuel and air in the correct ratio.

Pressure jet type burners are installed on all on all oil-fired central heating boilers, including Traditional boilers, Condensing boilers,

Combination boilers, Freestanding and wall mounted types.

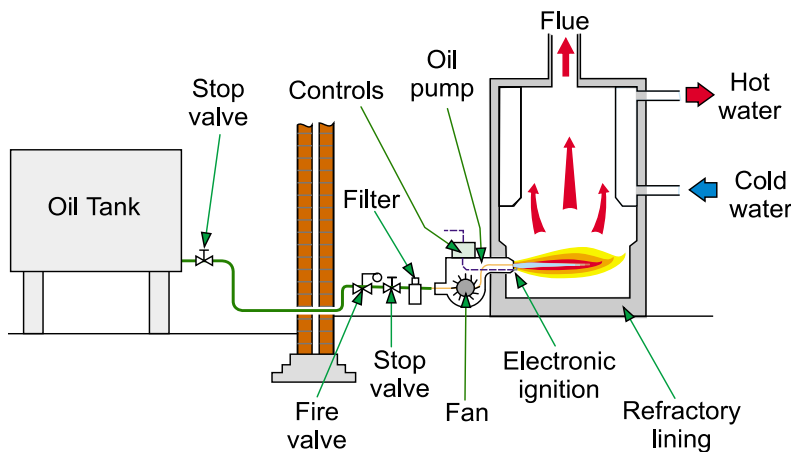

A pressure jet boiler installation

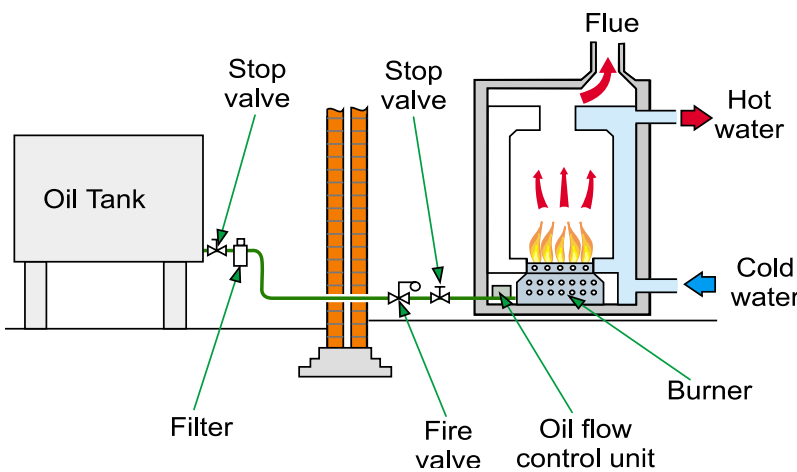

A vapourising burner installation

The principles of the vapourising burner

Vapourising burners work on the principle that the oil feed to the burner is supplied via gravity. The oil flows to the burner box where it is heated by a small heater to encourage the oil to vaporise. The vapour is then ignited by an electrode. Once the oil is ignited, the electrode is no longer required as the heat from the burner ensures continued vaporisation of the fuel.

Vapourising burner are now only found in older oil-fired cookers, such as aga's.

AC2.7 State the general operating principles of gas fired heat producing appliances

Gas fired central heating systems are the most popular form of heating in the United Kingdom. Over the past 100 years there have been many different types of boiler from large cast iron multi-sectional types to modern low water content condensing types. Modern boilers are available as wall mounted or freestanding (floor mounted) models to suit all installations and heat emitters.

Traditional boilers

Often called conventional, regular or heat only boilers, the traditional boiler is best suited as replacements to dwellings that already have a traditional central heating system installed that contains a hot water storage cylinder and a feed and expansion cistern in the roof space. They are very often used where the heating system may not be able to take the water pressure of a modern sealed heating system containing a system boiler or combination boiler. However, modern components, such as expansion vessels and filling loops can be fitted externally, if required.

Generally, traditional boilers have a low water content for quick heating response and all models are condensing type boilers that can take advantage of modern external heating controls such weather compensation or delayed start units.

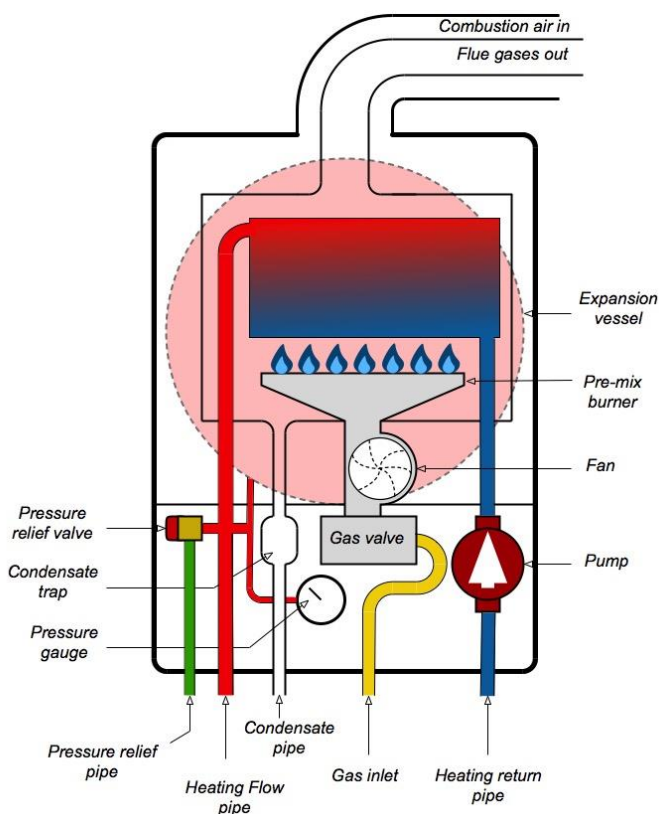

Traditional boilers are compatible with solar hot water heating systems that actively encourage a lower carbon footprint and energy cost savings.

System boilers

A system boiler is a heat only boiler that is used where sealed systems are installed. They contain all major hot water and heating system components built into the boiler casing, including the circulating pump, pressure relief valve, pressure gauge and expansion vessel. They require an external hot water storage cylinder for hot water supply. A separate feed and expansion cistern is not required as these boilers are filled with cold water taken directly from the water undertakers cold mains supply via a temporary filling loop.

System boilers are much easier to install than conventional boilers and require less pipework. Again, system boilers are compatible with modern

A system boiler

environmentally friendly systems such as solar hot water supply and underfloor heating systems. All sealed systems are of the condensing-type.

Condensing boilers

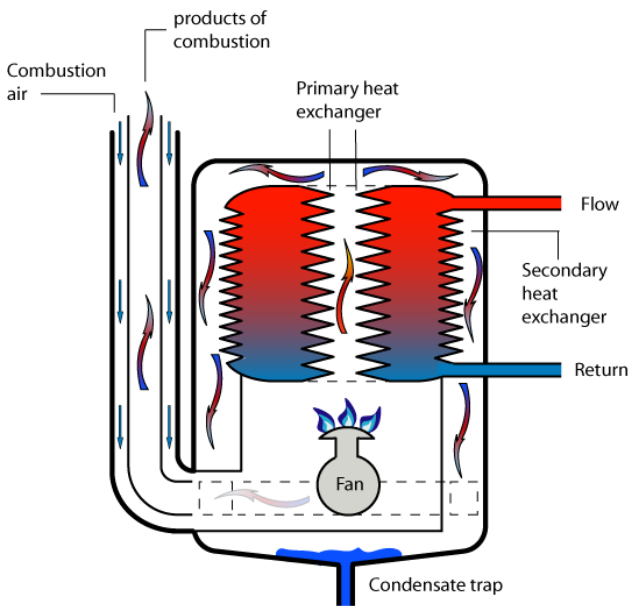

A condensing boiler

When natural gas is combusted, the resulting flue gases contain CO₂ and water vapour. If the gases are cooled to their dew point, the water vapour condenses back into droplets of water. It is this cooling and condensing process that is used in condensing boilers.

Condensing boilers have two heat exchangers. The flue gases first pass over the primary heat exchanger where about 80% of the heat is extracted. The gases then pass over another smaller heat exchanger where a further 14% of heat is extracted. It is at this point that the gases condense to water to form a plume of steam that is evacuated from the flue pipe. Condensate water that is collected inside the boiler is released through a condensate trap to a drain outside of the dwelling. The condensate water is heavily saturated with CO₂ which makes it extremely acidic. For this reason, condensate pipes must be installed in plastic solvent weld pipework.

Condensing boilers are around 94% efficient. This means that only 6% of heat is wasted from the flue. They are compatible with modern environmentally friendly systems such as solar hot water supply and underfloor heating systems.

Combination boilers

A combination boiler combines the benefits of a condensing boiler with instantaneous hot water supply. A hot water storage cylinder is not required because combination boilers heat the water as it is drawn directly from the water undertakers mains cold water supply. The heating system is a sealed system filled usually from an integral filling loop within the boiler.

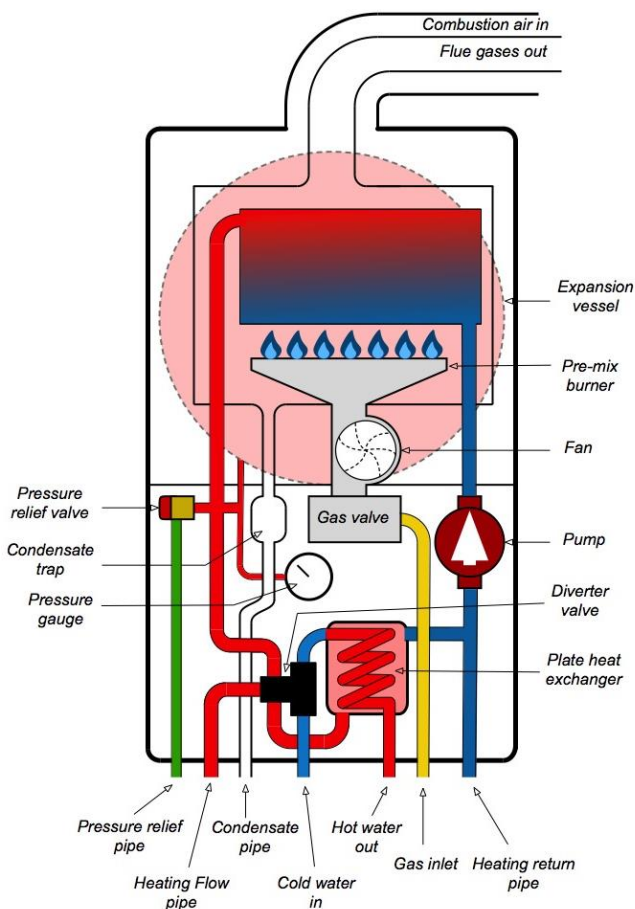

A combination boiler

A combination boiler contains a plate heat exchanger and a diverter valve. The diverter valve diverts the heated water from the boiler heat exchanger to either to the heating system or the plate heat exchanger. The plate heat exchanger heats the cold water as it comes from the cold mains supply before distributing it to the hot taps.

Combination boilers are known as 'hot water priority' appliances. This simply means that when a hot tap is opened, the heating system will go cold, whilst all of the heat energy is put through to the hot water supply. Once the tap is turned off, the diverter valve will then divert the water to the heating system once more.

Modern combination boilers give a much better hot water flow than older types, but it should be remembered that most combination boilers are not suitable where multiple hot taps may be opened or where there is a long run of pipework to the hot taps.

Flue types used with gas and oil fired boilers and appliances

All appliances that burn gas, oil and solid fuels need a flue system to evacuate the products of combustion away from the dwelling. The basic principle is to create an up-draught or a difference in pressure, whether by natural means or whether by the use of a fan, to eject the combustion products safely to atmosphere. There are two basic designs:

- Room sealed flues
- Open flues

Room sealed flues

The principle of a room sealed flue is that at no point should any flue gases escape into the room where the boiler/appliance is installed. The boiler draws its combustion air directly from outside and evacuates the fumes at the same point outside the building. This arrangement makes the appliance much safer, since there is direct path for the fumes to escape into the room. The internal combustion process is effectively 'room sealed'. There are two different methods:

Natural draught room sealed flues

Natural draught room sealed appliances (better known as balanced flues) have been around for many years. Both the products of combustion outlet and fresh combustion air inlet are positioned at the same location on an outside wall of a building. The products of combustion are cleared from the boiler via a duct that runs from the top of the combustion chamber and through the centre of the fresh air inlet duct. Fresh combustion air enters the boiler through the outer duct. The air pressure acting on both ducts is equal and 'balanced', hence the term 'balanced flue'.

Natural draught room sealed appliances are recognisable because of

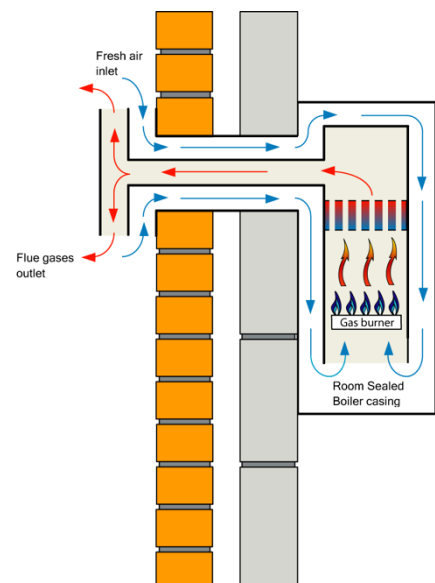

A natural draught room sealed boiler

their rather large, square or rectangular flue terminals, which are positioned so as not to allow fumes to re-enter the buildings through any openings, such as doors or windows..

Forced draught room sealed flues

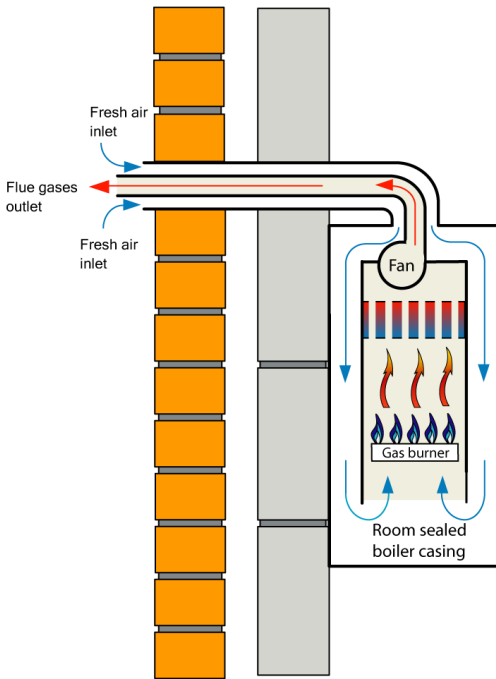

A forced draught room sealed boiler

Forced draught room sealed appliance, better known as ‘fan assisted’, work in exactly the same way as the natural draught room sealed appliances. There are, however, two notable differences:

- The flue outlet is circular in shape and much smaller.
- The products of combustion are evacuated from the appliance with the aid of a fan.

There are two distinct types of forced draught room sealed appliance:

1. Positive pressure – where the fan is positioned before the gas burner. The fan forces gas and air to a pre-mix gas burner where it is combusted. This creates a positive pressure inside the boiler casing. Generally used on condensing-type boilers.

2. Negative pressure – the fan is positioned on the flue gas outlet, where it pushes the products of combustion out of the appliance. This creates a negative pressure inside the boiler casing. Generally, this type of fan arrangement is used on pre-condensing appliances.

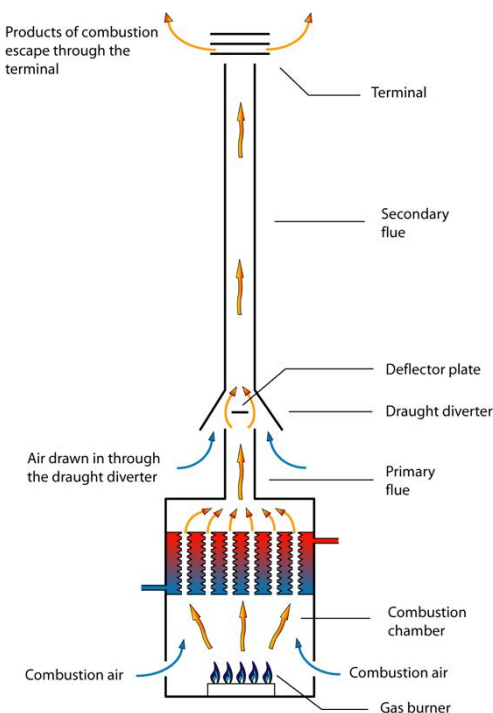

A typical open flue

Open flues

The flue is open to the room where the appliance is installed. Combustion air is drawn from the room where the appliance is installed. The combustion air used must be replaced by air from outside of the property through an air brick, usually (but not always) positioned on an outside wall in the room. There are two types:

- Natural draught open flue
- Forced draught open flue.

Natural draught open flues

Natural draught flues rely on the up-draught of the flue, which is created because the heat from the combustion process rises. Up-draught can be affected by the length of the flue, the height of the flue and the number and angle of any changes of direction. 90° bends should be avoided as these slow the evacuation of the

products of combustion. Natural draught open flues can also be adversely affected by wind and weather conditions and can suffer from the effects of condensation caused by the rapid cooling of the combustion gases inside the flue.

Forced draught open flues

On some appliances, open flues may be forced by the aid of a fan positioned either before the combustion chamber or close to the primary flue. The fan helps to create and maintain a positive up-draught by forcing the products of combustion up the flue and out to the atmosphere.

AC2.8 State the operating principles of heat emitters

In this assessment criteria, we will investigate the common forms of heat emitter that can be used with wet central heating systems.

Panel radiators

Panel radiators are the most popular form of heat emitter used on central heating systems. They have changed very little over the last 40 years but modern panel radiator are much more efficient than their predecessors.

Around 70% of the heat from modern panel radiators is in the form of convection. Almost all modern radiators have fins on the back and it is these fins (or convectors) that provide the majority of the heat. The fins warm the air trapped in them creating upward moving warm convection currents that flow into the room. This substantially raises the heat output of the radiator meaning that smaller radiators in most cases can be used.

Positioning of radiators needs to be considered with care. They should be positioned on walls that are clear of furniture, if possible, as the furniture can prohibit the effect of the radiated heat. If a radiator is to be positioned under a window, then enough space should be provided between the top of the radiator and the window sill to allow the free flow of warm air. When hanging radiators on a wall, a distance of 150mm between the bottom of the radiator and the finished floor level to allow the free circulation of air through the fins.

Manufacturers provide a wide range of radiator heights and lengths with heights from 300mm through to 900mm and lengths from 400mm to 3m.

There are three different panel radiator styles:

- Compact
 - Rolled top
 - Seamed top
 - Flat panel
-

Compact



Compact radiators have factory fitted top grill and side panels and are more aesthetically pleasing than other radiator types. The top grill and side panels can be removed to match seamed top radiators if desired.

Rolled top



Not as popular as compact radiators, these do not have any top grills or side panels. The top of the radiator has a rolled seamless appearance with welds along the sides and across the bottom. Generally, these are more expensive than compact radiators.

Seamed top

The seamed top radiators are made by welding two flat plates of steel together. At one time, these were the most popular radiator installed but have fallen out of popularity due to the introduction of the compact radiator.

Flat panel



These are becoming increasingly popular due to the smooth finish and stylish design that compliments modern living environments. They are very easy to keep clean and have a low profile, maximising the wall space. They can be mounted horizontally and vertically.

Domestic panel radiators have 1/2 inch BSP female threads on all ends for installation of the radiator valves. All radiators have an air release valves and plugs. These are usually supplied by the radiator manufacturer.

The types of panel radiator

There are many types of panel radiator from single panel to double panel with fins. These are shown in the drawing below:

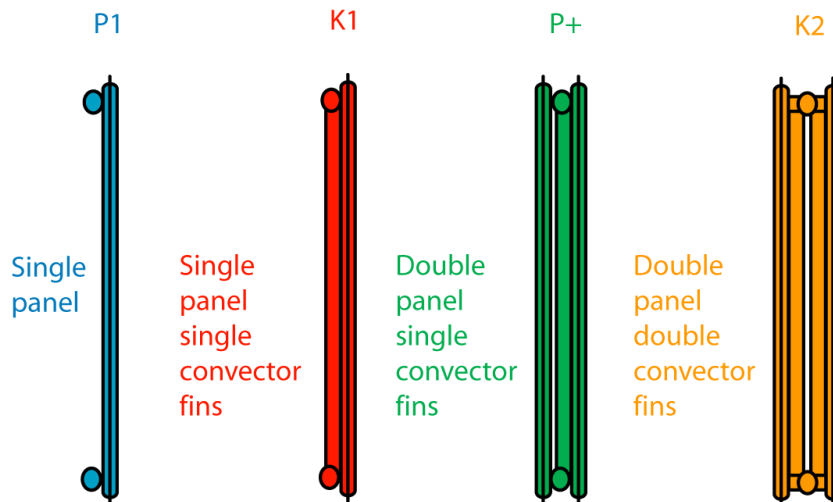

Connections to radiators

Radiator connections are classified by their abbreviations. For example:

- **TBOE** means Top-Bottom-Opposite-End (used on heat sink radiators with solid fuel systems and one pipe systems)
- **BBOE** means Bottom-Bottom-Opposite-End (the usual method of radiator connection)
- **TBSE** means Top-Bottom-Same-End (used occasionally on one pipe systems)

Column radiators



Column radiators are, as the name suggests, made from columns historically made from cast iron. The more columns a radiator has, the greater the output is. Modern column radiators may be made from cast aluminium or steel. They are often called church or hospital radiators because they were designed to withstand being installed in large public spaces. They are increasingly used on refurbishments where an historic 'period-feel' is important.

There are two disadvantages with column radiators:

1. They contain a lot of water, which means that they may take longer to heat up than convention panel radiators.
2. The heat is predominantly radiated heat with very little in the way of convection. This means that the radiators may be on the large side.

Low surface temperature radiators



Designed to comply to an HSE Health Services Information Sheet no.6, which states that:

Contact with surfaces above 43 °C can lead to serious injury. Prolonged contact often occurs because people have fallen and are unable to move, or are trapped by furniture. Incidents often occur in areas where there are low levels of supervision, for example in bedrooms, bathrooms and some communal areas.

This standard has been accepted by many local authorities and NHS establishments to include any place where the general public have access, including residential homes, care homes and schools. Low surface Temperature radiators are also becoming popular in many domestic situations too, especially in children's bedrooms and nurseries, and areas where the elderly or infirm may come into contact with radiators.

Inside each LST is a normal panel radiator. The outer shell is a specific distance away from the direct heat so that it never exceeds the 43°C limit. Bottom grill and top grill allow the passage of cooler air in and heated air out, so that the room is warmed sufficiently.

Fan convectors

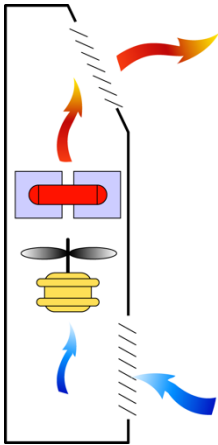

A fan heater

Fan convectors work by using an electrically operated fan blowing warm air into the room. The heat exchanger is usually a coil of copper pipe with aluminium fins attached that is connected to the flow and return pipes of the heating system. The fins trap the air and heat it quickly before the fan forces it out. A thermostat operates the fan by switching off the electricity once the temperature is reached. They are connected to the electricity supply via a switched fuse spur. There are two common types of fan convector:

Wall mounted

These are usually large in size. They can be successfully used on sealed heating systems where the temperatures can be slightly higher than open vented systems. Heat outputs vary with heater size and manufacturer's data should be checked for specific installation requirements.

Kick space heaters

These are specifically designed to fit below kitchen cupboards for use in kitchen areas with limited space for a radiator. They work in the same way as fan convectors.

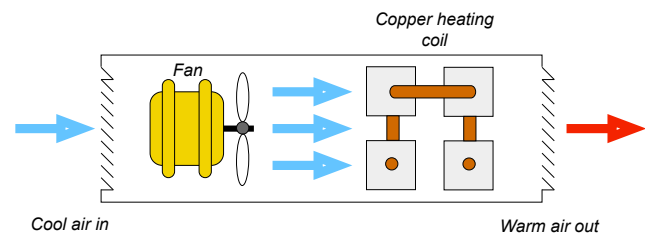

A kick space heater

Tubular towel warmers



Bathroom towel warmers are available in many sizes, styles and finishes and are often referred to as designer towel rails. Many have dual fuel capability, being used with wet central heating in the winter and using a small electrical element to heat them during the summer when the heating system is not used. They are usually vertically mounted

Towel warmers with integral panel radiators

Not as popular as tubular towel warmers, these combine a towel warmer with a radiator. The idea is to warm the towel but not affect the convection currents warming the bathroom. They are usually used in period bathrooms, where modern heating efficiency meets classic styling.



AC2.9 State the operating principles of central heating control components

Modern central heating components can be divided into two main groups:

- Those components that are mechanical in nature
- Those components that are electrical

Mechanical central heating components

Mechanical central heating components do not require an electricity supply to operate but still provide an important function in the efficient running of the system

Thermostatic Radiator valves



A trv

These control the temperature of the room by controlling water flow. TRVs contain heat sensitive head workings that reacts to air temperature. The head is usually filled with wax or a heat sensitive liquid that expands and contracts with heat. When the room heats up, the wax/liquid in the head of the valve expands, which pushes down on a central pin. The pin opens/closes the valve in response to the expansion/contraction of the wax/liquid. Each TRV has a range of temperature settings to allow different temperatures as required by the end user. Most TRVs can be installed on either the flow or the return.

Building Regulations Approved Document L1A/B requires that TRVs be fitted in all rooms except where a room thermostat is sited.

Manual Radiator valves

There are two types of manual radiator valve. These are the wheel head and the lockshield type. Radiator valves do not contain a washer. Instead the water flow is shut off by a metal to metal seating that is carefully designed stop the flow of water through the radiator. Wheel head valves can be controlled by the end user by turning clockwise to turn off and anti-clockwise to turn on. Lockshield type valves do not have an operating wheel head as they are designed to be set by the plumber during the balancing operation at the commissioning stage of the heating installation. They have a cover designed to prevent tampering with the valve once it has been set.



A wheel head radiator valve

Automatic air valves

Automatic air valves are used to automatically release the air from the system. They are usually placed in positions where air is expected to collect, usually at high points in the system pipework. They operate by allowing the air to escape and then resealing themselves when water arrives at the air release point.

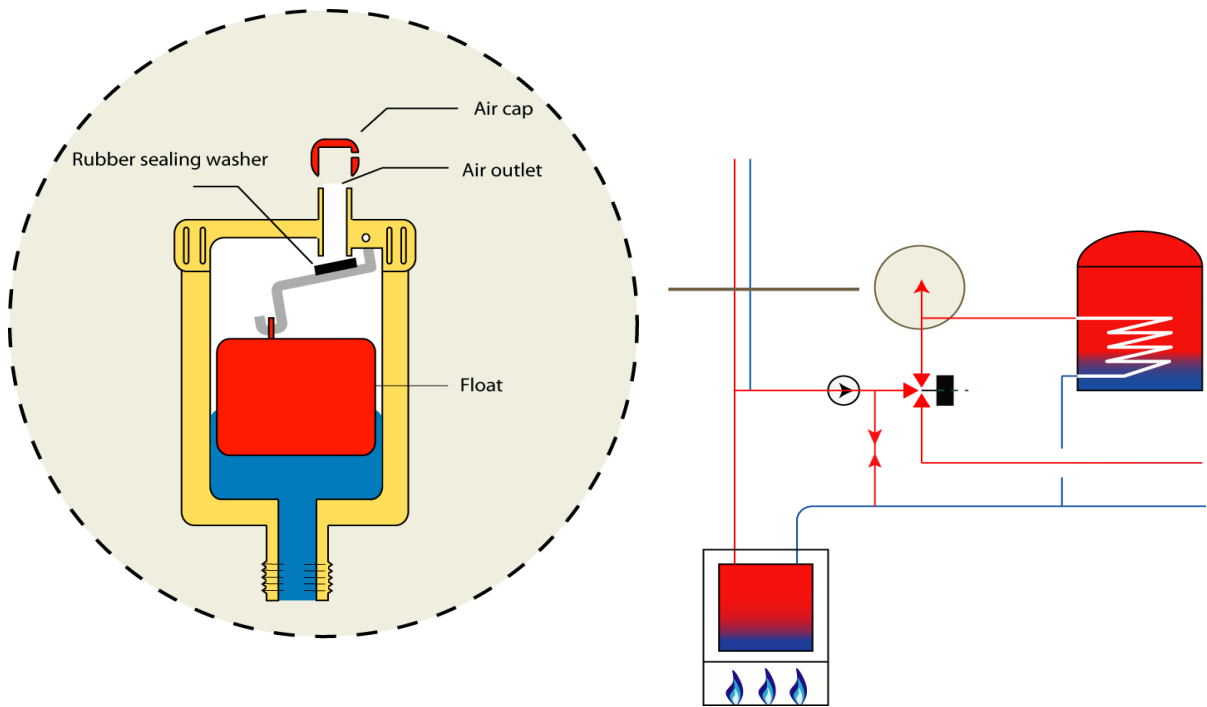

How do AAVs work?

When the water reaches the AAV, the float and the float arm inside the valve rises as the water enters the valve until the valve closes. As more air arrives at the valve, the float momentarily drops and the valve opens releasing the air from the system. They are often used in conjunction with a single check valve as this would prevent air from being drawn into the system through the AAV.

Automatic bypass valves



The automatic by-pass valve

The automatic by-pass valve is a spring operated valve that controls the flow of water across the flow and return circuits in situations where no flow is possible due to motorised valve and thermostatic radiator valve closure. This condition can occur in S Plan and S Plan Plus systems, especially when the hot water circuit is closed and the TRVs on the heating circuit begin to close one by one when all thermostatic heads have been satisfied. As the TRVs close, the by-pass valve will gradually open in response, maintaining minimum circulation through the boiler. This prevents boiler over heat and the operation of the high-limit thermostat on the boiler.

By-pass valves can be set to respond to the flow rate of the system. They are marked in litres/second (l/s) through the valve.

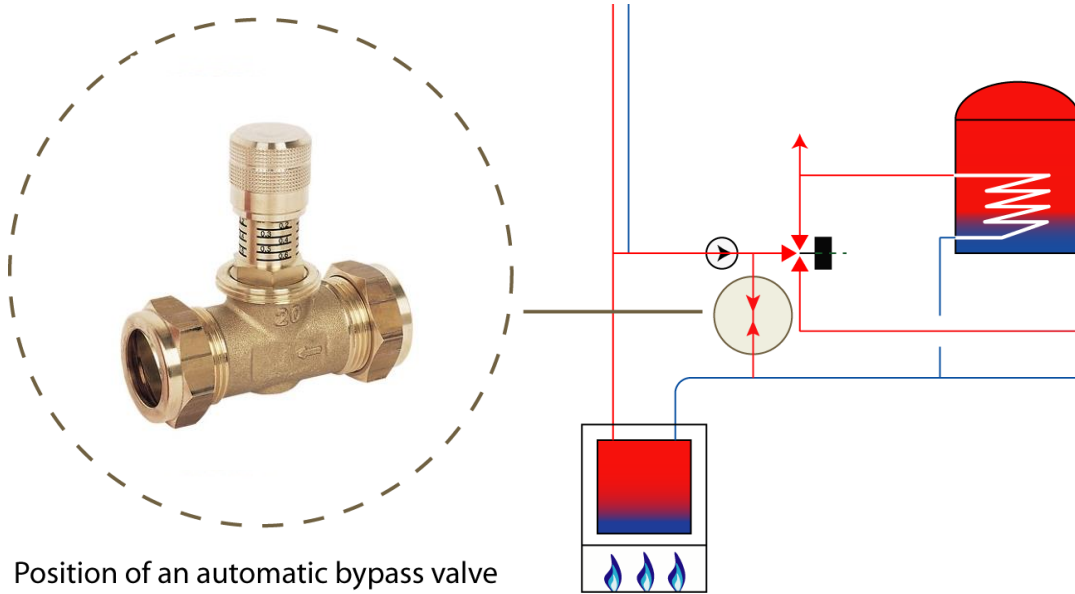

Position of an automatic bypass valve

Thermo-mechanical cylinder control valves



A thermo-mechanical cylinder control valve

These are non-electrical valves that are used in existing semi-gravity systems to control the temperature of the hot water. They are positioned on either the primary flow or the return with the temperature sensing capillary fastened to the wall of the hot water storage cylinder.

According to the Domestic Heating Compliance Guide they are:

'For replacement systems where only the hot water cylinder is being replaced and where hot water is on a gravity circulation system, a thermo-mechanical cylinder thermostat should be installed as a minimum provision.'

Thermo-mechanical valves operate on the same principle as thermostatic radiator valves in that the flow of water is controlled by a thermostatic head. In this instance, the head is controlled by the temperature of the water inside the hot water storage cylinder via the temperature sensing capillary.

The temperature sensing capillary should be positioned about $\frac{1}{4}$ to $\frac{1}{3}$ of the way up from the bottom of the storage cylinder.

Anti-gravity valves

Anti-gravity valves work in the same way as a single check valve by only allowing water flow in one direction.

Anti-gravity valves stop unwanted gravity circulation of heat to the upstairs radiators of semi-gravity heating systems when the system is on hot water only. They are particularly important on systems fuelled by solid fuel and, since they do not contain a spring, should be positioned on the vertical flow pipe to the upstairs heating circuit so that the valve drops to the closed position when the pump is off and is forced open when the pump is operating.



Radiator valve with drain-off

Drain valves

Drain valves should be positioned at all low points in the heating system to allow total draining of the system water. If the radiators are connected via pipe drops from above, then every radiator should have its own drain-off valve to facilitate draining. Radiator valves with built-in drain-off valves are available.

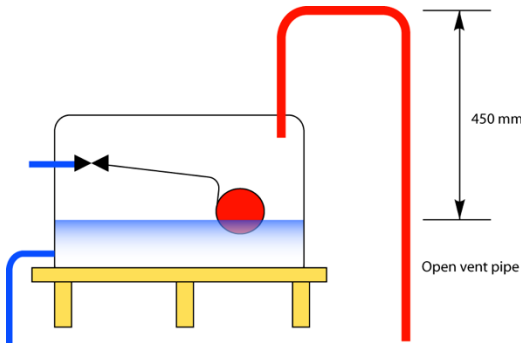

An F&E cistern

Feed and expansion cisterns

These small cisterns that are designed for use with vented hot water heating systems. They supply cold feed water to a heating system, and they accommodate any expansion of the water due to the water being heated. The cistern must be large enough accommodate any expanded water and must be sized accordingly. See Unit **H/602/2697 - Understand and apply domestic cold water system installation and maintenance techniques.**

Feed and expansion cisterns should be installed so that the cold water content when the system is full is only about 100mm from the bottom of the cistern to the water line. This is so that there is enough room for the water to expand without it causing the cistern overflow pipe to run when the system is hot.

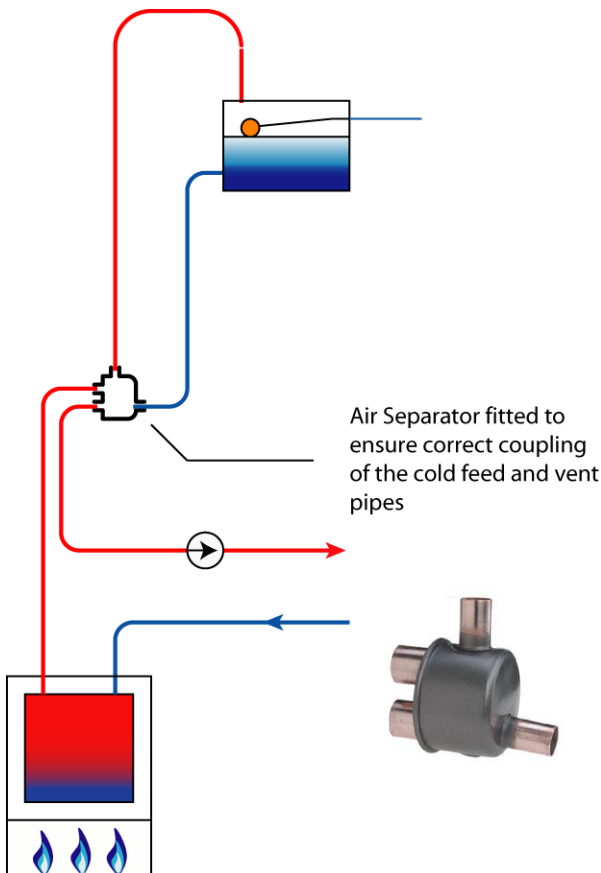

Use and position of an air separator

Air Separators

An air separator is designed to help with the positioning of the feed and open vent connections to the system pipework. When positioned correctly, the air separator creates a turbulent flow of water within the air separator itself and this helps to eject any unwanted air from the system.

Electrical central heating components

Modern, energy efficient central heating controls are necessary to provide the functional, efficiency and safety requirements of Building Regulations Approved Document L1A/B Conservation of Fuel and Power.

Before we investigate the various controls and their functions, it is worth considering what the requirements of Document L1A/B actually are:

The following information is quoted verbatim from the TACMA-guide-to-Part-L1A/B.	
CONTROLS FOR NEW DWELLINGS	CONTROLS FOR EXISTING DWELLINGS
Part L1A, England and Wales:	Part L 1B, England and Wales.
<ol style="list-style-type: none"> 1. Provide installations that are fully pumped. 2. Provide independent time & temperature control to both the heating and hot water circuits. Part J, Scotland requires the installation of 7-day timing. 3. Provide control systems with a boiler interlock. Note 1 4. Install an automatic by-pass valve if a bypass is fitted. Note 2 5. Split the heating circuit into zones using either: <ol style="list-style-type: none"> a. room thermostats or programmable room thermostats in all zones. b. a room thermostat or programmable room thermostat in the main zone and Thermostatic c. Radiator Valves (TRV's) on all radiators in the other zones. 6. Ensure installation of a cylinder thermostat and a zone valve to control stored hot water. Note 3 7. Provide time control by the use of either: <ol style="list-style-type: none"> a. a full programmer with separate timing to each circuit. b. two or more separate timers providing timing control to each circuit c. programmable room thermostat(s) to the heating circuit(s), with separate timing of the hot water. 8. For dwellings with a total usable floor space greater than 150m², then: <ol style="list-style-type: none"> a. the heating circuit should be split into a minimum of two zones plus a hot water service zone and: b. each zone should be separately timed by the use of a multi-channel programmer or multiple heating programmers or programmable room thermostats 9. Any Boiler Management Control System that meets the specified zoning, timing & temperature requirements is a wholly acceptable alternative. 	<p>When a new installation is fitted, the controls should be as for a new dwelling. When replacing the boiler and/or the hot water vessel, the opportunity to improve the controls should be considered. To be confident that the requirements of the Building Regulations are met this would entail the following:</p> <ol style="list-style-type: none"> 1) Provide fully pumped installations with a boiler interlock. Note 1 2) Install an automatic by-pass valve, if a bypass is fitted. Note 2 3) Provide time and temperature control to both the heating & hot water circuits, for fully pumped installations. <p>4.1) Separate the space heating system into zones and:</p> <ol style="list-style-type: none"> a. if a room thermostat is already fitted fit TRV's on at least all radiators in the sleeping areas and check if a new room thermostat or programmable room thermostat should be fitted. b. if there is no room thermostat, install either a room thermostat or programmable room thermostat and fit TRV's on at least all radiators in the sleeping areas. <p>4.2) Provide time control by the use of either:</p> <ol style="list-style-type: none"> a) a full, standard or mini programmer, or b) one or more separate time switches, or c) programmable room thermostat(s). <p>5) For semi-gravity installations, the recommended option is to convert it to fully pumped. The controls should then be as detailed above.</p> <p>5.1) If either the new boiler or hot water storage vessel can only be used on a pumped circuit, the installation must be converted to fully pumped. Install controls as detailed above.</p> <p>5.2) If the new boiler or storage vessel is designed for gravity hot water, or it is impractical to convert to a fully pumped installation, provide the following controls:</p> <ol style="list-style-type: none"> a. a cylinder thermostat & zone valve to control the hot water and provide a boiler interlock. Note 3 b. a room or programmable room thermostat. c. a programmer or time switch.

- d. TRV's on at least all radiators in the bedrooms.
- 6) Any Boiler Management Control System that meets the specified zoning, timing & temperature requirements, is a wholly acceptable alternative.

Note 1: Boiler interlock is achieved by the correct use of the room thermostat(s) or programmable room thermostat(s), the cylinder thermostat and zone valve(s) in conjunction with the timing device(s). These should be wired such that when there is no demand from the heating or hot water both the pump and boiler are switched off. The use of TRV's alone does not provide interlock.

Note 2: Although the regulations may not always require a bypass to be fitted, the performance of any installation with multi-zoning or TRV's is improved by the use of an automatic by-pass valve.

Note 3: The use of non-electric hot water controllers does not meet this requirement.

Central Heating Circulating Pump

The circulating pump operates by circulating the water around the system. It is not a pump in the true sense of the word, since it needs water both sides of the impeller to operate correctly.

Domestic circulating pumps have either a 6m or 10m head of pressure capability meaning that they will lift the water vertically either 6m or 10m. This is normally sufficient for most domestic systems.

Timeclocks and programmers



A typical programmer

Timeclocks provide a simple way of activating a central heating system. They are only suitable for switching on or off one circuit, such as the heating circuit. This makes them ideal for systems that incorporate a combination boiler. Mechanical and digital types are available.

Programmers are two-way timeclocks, able to switch two circuits at multiple times throughout the day. There are three types:

- **Mini programmers** – these allow the heating and hot water circuits to be on together, hot water independently but not heating independently.
- **Standard programmers** – these use the same time settings for all circuits.
- **Full programmers** – these allow multiple independent settings for both circuits. Each circuit can be used on its own or together.

Room thermostats



A hive room thermostat

A room thermostat controls the air temperature of the room. It is basically a thermostatically controlled switch that either makes or breaks an electrical connection controlling the heating circuit.

Some room thermostats are programmable, allowing different temperatures at different times of the day and on different days of the week and many provide a 'night setback' facility where a minimum temperature can be maintained throughout the night. This is particularly useful during the winter months.



Cylinder thermostats

These control the temperature of the hot water that is stored in the hot water storage cylinder. They are strapped to the cylinder about ¼ of the way up from the bottom of the storage vessel. They are used in close conjunction with a motorised zone valve or diverter/mid position valve to provide accurate temperature control.

Frost and pipe thermostats

Frost thermostats and pipe thermostats work together to provide protection for the vulnerable parts of the system that may be affected by freezing temperatures:

- The **frost thermostat** is wired to the boiler and any other vulnerable components and is designed to override all other controls and programmers/timelocks. They should be set to around 3°C and should be positioned in places where frost and freezing temperatures are likely to affect the system such as boilers installed in room spaces and unheated garages.



Frost thermostat

- **Pipe thermostats** should be wired in series to the frost thermostat. A pipe stat is fastened to vulnerable pipework near, say, to a boiler installed in a garage. The pipe stat senses the temperature of the water in the system and will only activate if this approaches 0°C.

When both frost and pipe thermostat are activated, then the system will fire up, protecting the system from freezing.



Pipe thermostat

Motorised valves

There are three motorised valves that can be used to control domestic heating systems:

- The two port motorised zone valve
- The three port motorised mid-position valve

- The three port motorised diverter valve

The two port motorised zone valve

These are used primarily on S Plan and S Plan Plus heating systems but may also be used on C Plan Plus systems. Each valve is wired to control either a room thermostat or a hot water cylinder thermostat. They are mostly used to 'zone' parts of heating systems for better thermostatic and energy efficiency control of heating systems.



The three port motorised mid-position valve

These are used exclusively on Y Plan domestic heating systems. The valve is linked to both room and cylinder thermostats and operates by opening or closing the heating or hot water circuits. With the mid position valve, at least one circuit is open all of the time. It is not possible to close both hot water and heating circuits simultaneously. When both circuits are required, the valve swings to the mid-position allowing hot water to flow to both circuits.

The three-port motorised diverter valve

These are very similar in appearance to the three port mid-position valve but they will only open one circuit at a time. There is no mid-position function. They are specifically designed for the W Plan fully pumped system.



AC2.10 State the operating principles of devices used in central heating systems to minimise the build-up of

sediment

The effects of dissimilar metals used on central heating systems

Corrosion in central heating systems occurs because of the different metals that the system contains. Electrolytic corrosion takes place where dissimilar metals are placed in close proximity with each other in the presence of an electrolyte – in this case the electrolyte is water (see unit **J/602/2496** Understand how to apply scientific principles within MES). This leads to the formation of magnetic black oxide sludge and sediment that settles in low spots in the system, around the magnetised impeller in the pump and at the bottom of radiators and heat emitters.



Corrosion can attack systems extremely quickly and begins almost as soon as the system is filled with fresh oxygenated water from the mains cold water supply. The problem then accelerates once the water gets hot.

Corrosion can be prevented by using the correct flushing procedures to remove excess flux residues and swarf and then adding corrosion inhibitors and descaling additives to the system water when the system is still new. For existing systems, magnetic filters prove effective at removing sludge and sediment as it circulates through the system in the system water.

It should be remembered, however, that not all corrosion in central heating systems is magnetic. Black oxide sludge is magnetic because it is derived from the ferrous steel used in the manufacture of the radiators but corrosion of non-ferrous metals, such as copper and aluminium also takes place, and this cannot be removed by the use of magnetic filters. Protection of central heating systems is a combination of the following:

- System flushing to remove residues
- Adding corrosion inhibitors and scale preventers
- The use of magnetic filters

These three points, together with regular servicing and maintenance will protect the system and ensure its continued efficient service throughout its life.

Magnetic central heating filters



The concept of magnetic central heating filters is to remove the magnetic sludge and sediment by the use of a very powerful magnet that attracts the sediment as it circulates through the central heating system. The magnetic filter should be installed on the return pipe, close to the boiler and should be regularly inspected and cleaned to prevent sediment build-up.

A NOTE OF CAUTION: It is recommended that people with heart pacemakers etc should not handle the magnet inside the magnetic filter. When the filter is correctly installed and inside its water tight compartment, the strength of the magnetic field is around $\frac{1}{10}$ of that of the average fridge magnet and so poses very little risk. Always follow the manufacturer's installation and servicing instructions.

Learning Outcome 3

Know the site preparation techniques for central heating systems and components

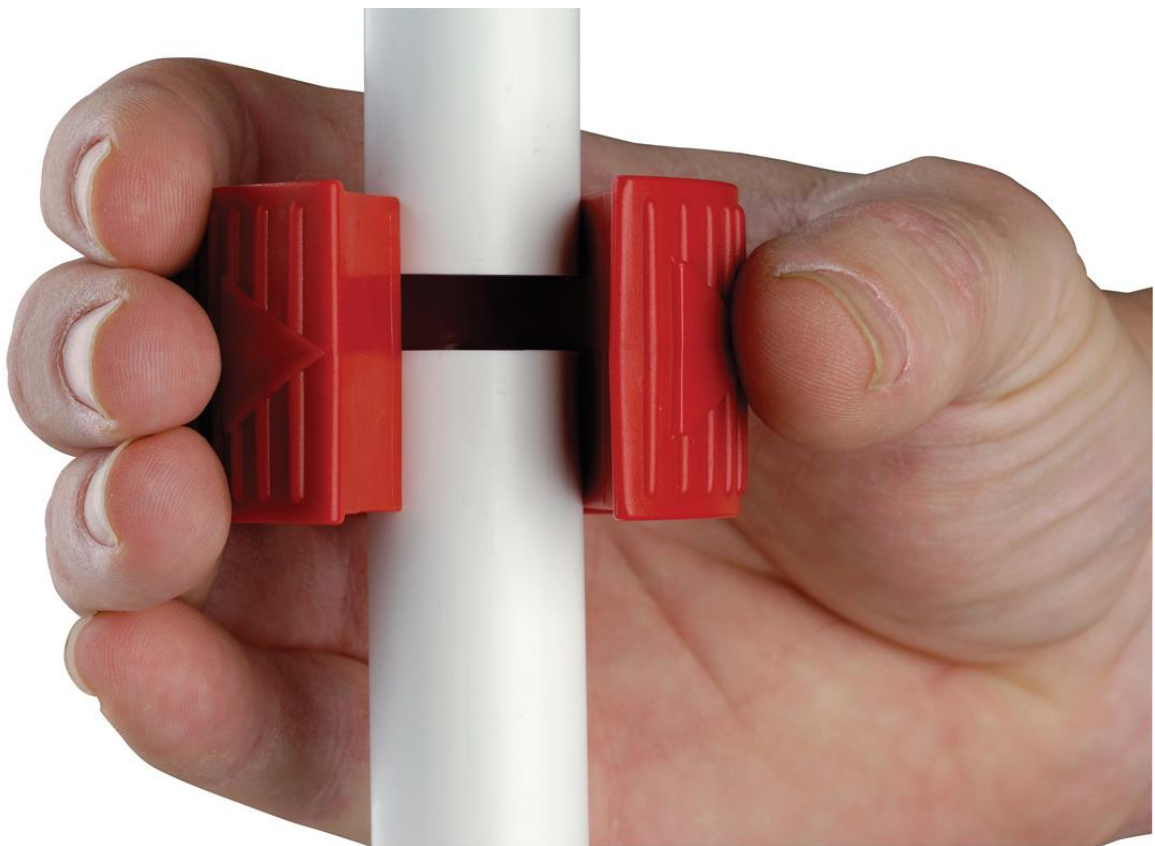

There are five Assessment Criteria in this Learning Outcome:

- AC3.1.** Identify the sources of information required when undertaking work on central heating systems:
- AC3.2.** Identify the preparatory work required to be carried out to the building fabric in order to install, decommission or maintain central heating systems.
- AC3.3.** Identify the protection measures required to the building fabric or customer property, during and on completion of work on central heating systems and components.
- AC3.4.** Identify the pipework materials and fittings required to complete work on central heating systems ensuring that they are not damaged.
- AC3.5.** State the range of hand and power tools required to complete work on central heating systems.

Much of the information in Learning Outcome 2 has previously been covered in detail in other Units and specifically in Unit **H/602/2697 - Understand and apply domestic cold water system installation and maintenance techniques**, and where possible, you will be directed to the relevant headings and Assessment Criteria within those units.

AC3.1 Identify the sources of information required when undertaking work on central heating systems

Regulations

The Regulations required when designing, installing and maintaining hot water systems are almost the same as for the installation of cold water systems. As such, they are covered in detail in Unit **H/602/2697 - Understand and apply domestic cold water system installation and maintenance techniques**. Where there are differences, they are listed below:

- The Water Supply (water fittings) Regulations 1999
- The Private Water Supply Regulations 2016
- Building Regulations Approved Document L1A/B – Conservation of fuel and power
- Building Regulations Approved Document J – Combustion appliances and fuel storage systems

The British Standards

- **BS EN 12828:2012+A1:2014:** Heating systems in buildings. Design for water-based heating systems.
 - **BS EN 12831-1:2017:** Energy performance of buildings. Method for calculation of the design heat load. Space heating load, Module M3-3
 - **BS EN 14336:2004:** Heating systems in buildings. Installation and commissioning of water based heating systems
 - **BS EN 1264-1:2011:** Water based surface embedded heating and cooling systems. Definitions and
-

symbols

- **BS EN 1264-3:2009:** Water based surface embedded heating and cooling systems. Dimensioning.
- **BSEN 1264-4:2009:** Water based surface embedded heating and cooling systems. Installation.
- **BS EN 442-1:2014:** Radiators and convectors. Technical specifications and requirements
- **BS EN 442-2:2014:** Radiators and convectors. Test methods and rating
- **BS 7593: 2006:** Code of practice for treatment of water in domestic hot water central heating systems

Recommendation and advice documents

- **The Domestic Building Services Compliance Guide 2018** – A free document that can be downloaded from :
https://logiccertification.com/media/72302/domestic-building-control-compliance-guide_2018.pdf
This document offers practical assistance when designing and installing to the Building Regulations requirements for space heating and hot water systems. It also includes advice on mechanical ventilation, comfort cooling, fixed internal and external lighting, and renewable energy systems.
- **The Central Heating System Specifications (CHeSS) 2008** – this publication offers advice for compliance with good practice and best practice for the installation of central heating systems.
- **Chartered Institute of Building Services Engineers (CIBSE) Heating Guide B1 2016** – this was produced to assist heating engineers to specify and design wet central heating systems.

Manufacturer technical instructions

The manufacturer's instructions are probably the most important document to read and consult when installing, servicing and maintaining appliances, components and equipment, because they instruct us on the best methods to use whilst keeping to current legislation and regulations. In some cases, it may appear that these instructions contradict the regulations. This occurs because regulations and codes of practice are only updated periodically, whereas manufacturers are constantly reviewing and updating their literature in line with modifications and current good practice. Where a conflict exists, manufacturer's literature should always be followed. If not:

- The warranty of the equipment may be void.
- Regulations may be inadvertently broken
- The installation may be dangerous.

AC3.2 Identify the preparatory work required to be undertaken to the building fabric in order to install, decommission or maintain central heating systems

This topic was covered in Unit **D/602/2682 - Understand and carry out site preparation, and pipework fabrication techniques for domestic plumbing and heating systems**, Learning Outcome 3, AC3.1: Define the

typical range of activities to be carried out when working on plumbing and heating systems and AC3.8: State the work methods for preparing building construction features for installation work

AC3.3 Identify the protection measures required to the building fabric or customer property, during and on completion of work on central heating systems and components

This topic was covered in Unit **D/602/2682 - Understand and carry out site preparation, and pipework fabrication techniques for domestic plumbing and heating systems**, Learning Outcome 3, AC3.4: Identify how to protect the building fabric or customer property before the work commences.

AC3.4 Identify the pipework materials and fittings required to complete work on central heating systems ensuring they are not damaged

This topic was covered in Unit **D/602/2682 - Understand and carry out site preparation, and pipework fabrication techniques for domestic plumbing and heating systems**, Learning Outcome 2, in the following Assessment Criteria:

- AC2.1.** Identify pipe work materials used in domestic plumbing and heating work
- AC2.2.** State the range of typical pipe material sizes available for use in dwellings.
- AC2.3.** State the acceptable methods of jointing new hot and cold water pipe to existing lead pipe work.
- AC2.4.** Identify the general fitting types used in dwellings.

AC3.5 State the range of hand and power tools required to complete work on central heating systems

This topic was covered in Unit **D/602/2682 - Understand and carry out site preparation, and pipework fabrication techniques for domestic plumbing and heating systems**, Learning Outcome 1, in the following Assessment Criteria:

- AC1.1.** State the purpose of hand and power tools used to carry out work on plumbing and heating systems.
 - AC1.2.** Identify the different types of hand and power tools used to carry out work on plumbing and heating systems.
-

Advert



BRAND NEW Plumbing Textbooks

Level 3 Plumbing and Domestic Heating
Phase 1 Textbook now available!



Created specifically to support learners studying
plumbing and domestic heating qualifications

Learning Outcome 5

Know the installation requirements of central heating systems and components



There are ten Assessment Criteria in this Learning Outcome:

- AC5.1.** State the procedures required to assemble valves to radiators and mount radiators on wall surfaces.
- AC5.2.** State the positioning and fixing requirements of central heating pipework and components
- AC5.3.** Identify how expansion and contraction may be catered for in central heating pipework containing
- AC5.4.** State how to select clips and brackets appropriate to the hot water system pipework and the industry recommended spacings
- AC5.5.** Identify how to select joints for use in central heating system pipework
- AC5.6.** State the positioning and fixing requirements of components in central heating systems
- AC5.7.** Identify suitable methods for making new central heating pipework connections to components
- AC5.8.** State how to position, fix and connect new central heating pipework to components
- AC5.9.** Identify suitable methods for making new central heating pipework connections into existing central heating circuits
- AC5.10.** Identify the insulation requirements of central heating system components

Much of the information in Learning Outcome 5 has previously been covered in detail in other Units and specifically in Unit **H/602/2697 - Understand and apply domestic cold water system installation and maintenance techniques**, Unit **F/602/2884 Understand and apply domestic hot water system installation and maintenance techniques** and Unit **D/602/2682 Understand and carry out site preparation, and pipework fabrication techniques for domestic plumbing and heating systems**, and where possible, you will be directed to the relevant headings and Assessment Criteria within those units.

AC5.1 State the procedures required to assemble valves to radiators and mount radiators on wall surfaces

Before the radiator is hung on the wall – dressing a radiator

Dressing a radiator involves preparing the radiator ready for hanging by positioning the valves, the air release valve and the blanking plug. The process is:

1. Remove the radiator from its packaging. Inside the packaging are the radiator brackets, the air release valve and the blanking plug.
 2. Take out the factory fitted plugs. Care must be taken when working in a furnished property as the radiator may contain a small amount of water from when the radiator was factory tested.
-

3. Split the valves at the valve unions and wrap PTFE tape around the valve tail. 10 to 15 wraps of PTFE around the tail will ensure that the joint between tail and radiator does not leak. Jointing compound may also be used if necessary.
4. Make the tail into the radiator using a radiator spanner and re-assemble the valve.
5. Screw in and tighten the air release valve and blanking plug using an adjustable spanner. Do not use water pump pliers as most air release valves are finished in chrome and these may become damaged if water pump pliers are used. Alternatively a ratchet-type ring spanner of the correct size may also be used

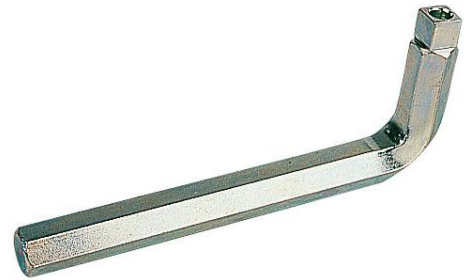

Hanging the radiator on the wall

1. Consult with the customer and decide on the position of the radiator.
2. Mark the centre of the radiator and the position of the hangers on the radiator itself.
3. Mark the centre of where the radiator is to be hung on the wall and place the radiator centre against that mark.
4. Mark the position of both brackets on the wall. Using a spirit level draw two vertical lines where the radiator brackets are going to be positioned

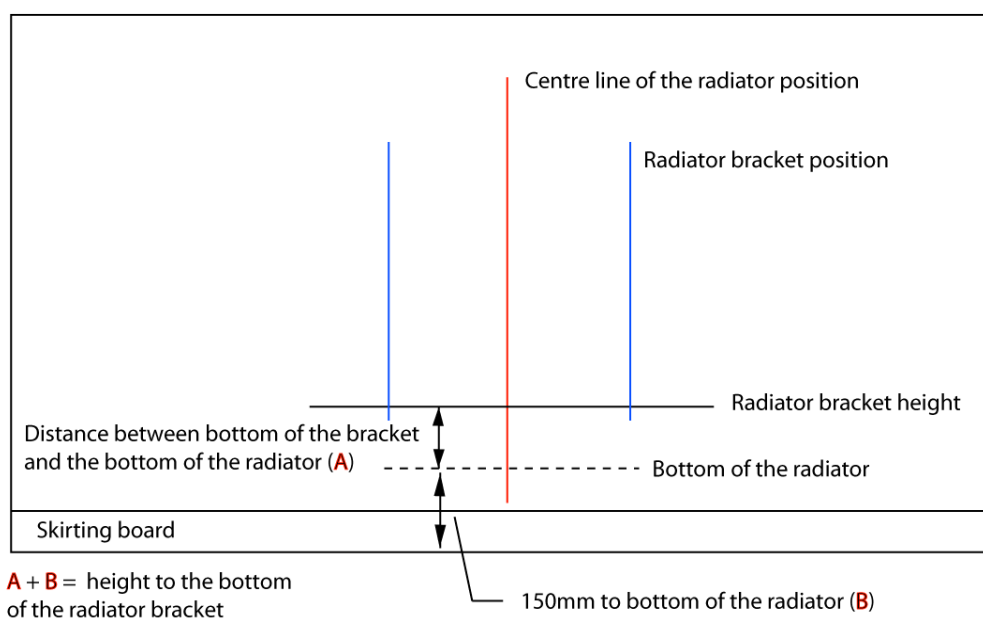
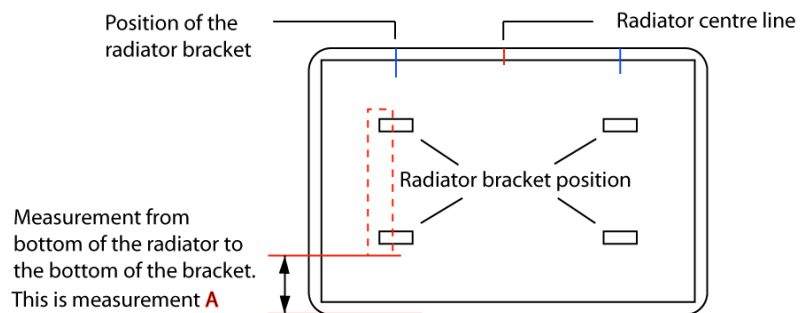

5. Place the radiator bracket in position on the radiator and measure from the bottom of the bracket to the bottom of the radiator.

6. Add 150mm (A) and the distance from the bottom of the radiator to the bracket (B) together. This will be the position of the radiator brackets on the wall. Draw a horizontal line at that distance on the wall using a spirit level. Make sure it connects with the vertical bracket position lines. This will ensure that the bottom of the radiator is the recommended distance of 150mm from finished floor level.
7. Radiator brackets usually have two positions a) one that will make the radiator close to the wall, and b) one that will leave a gap behind the radiator. Decide which way the brackets are to be fixed and position the bracket so that it touches both the bottom line and the vertical upright line (see diagram below).

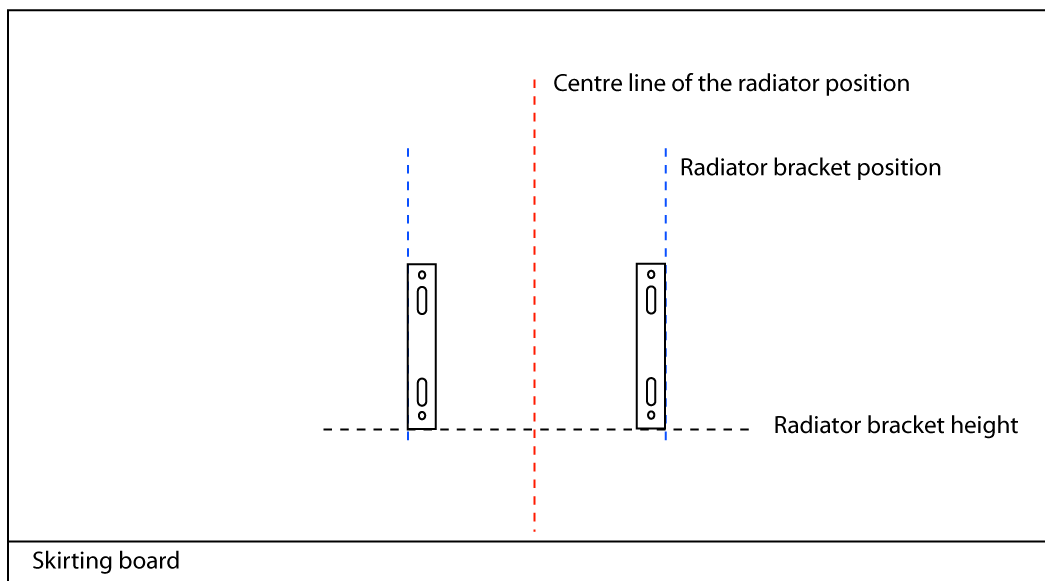

8. Mark the radiator brackets fixing holes on the wall.
9. The wall can now be drilled to fix the brackets.
 - a. If the wall is made of masonry/brick etc. drill the four holes using a 110V or cordless drill using a masonry bit. A 7mm bit with brown wall plugs is normally suitable. Use the appropriate PPE, goggles etc. 50mm x 10 gauge screws are usually adequate but this will depend on the wall structure.
 - b. For plasterboard walls use suitable wall fixings that will carry the weight of the radiator and the water inside.
10. Hang the radiator on the brackets and check for level using a spirit level.

AC5.2 State the positioning and fixing requirements of central heating pipework and components

The positioning and fixing of pipework and components was discussed in detail in Unit **H/602/2697 - Understand and apply domestic cold water system installation and maintenance techniques**, Learning Outcome 5, AC5.6 State the positioning and fixing requirements for cold water system pipework and

components:

- a) In suspended timber floors
- b) In solid floors
- c) Embedded in walls
- d) In areas of the building subject to frost
- e) That may be exposed to warming.

Please refer to Learning Outcome 5, AC5.6 of Unit **H/602/2697**.

AC5.3 Identify how expansion and contraction may be catered for in central heating pipework

This subject was dealt with in Unit **F/602/2884 Understand and apply domestic hot water system installation and maintenance techniques**, Learning Outcome 4, AC4.3 Identify how expansion and contraction may be catered for in hot water pipework containing plastics and copper.

AC5.4 State how to select clips and brackets appropriate to the hot water system pipework and the industry recommended spacings

The types of clips and clip spacings were dealt with in Unit **D/602/2682 Understand and carry out site preparation, and pipework fabrication techniques for domestic plumbing and heating systems**, LO5, AC5.4 Identify clip and bracket types for domestic plumbing and heating work.

AC5.5 Identify how to select joints for use in central heating system pipework

This topic was covered in Unit **D/602/2682 - Understand and carry out site preparation, and pipework fabrication techniques for domestic plumbing and heating systems**, Learning Outcome 2, in the following Assessment Criteria:

- AC2.1.** Identify pipe work materials used in domestic plumbing and heating work
 - AC2.2.** State the range of typical pipe material sizes available for use in dwellings.
 - AC2.3.** State the acceptable methods of jointing new hot and cold water pipe to existing lead pipe work.
 - AC2.4.** Identify the general fitting types used in dwellings.
-

AC5.6 State the positioning and fixing requirements of components in central heating systems

Radiator valves – thermostatic and manual valves

Each radiator in the property will require radiator valves. These should have a TRV and a lockshield valve for every radiator except the radiator in the room where the room thermostat is situated. This radiator should have standard wheel head and lockshield radiator valves.

Automatic air vents

Automatic Air Valves can be installed in parts of the system that are susceptible to airlocks, such as high spots in the pipework. These should be fitted with single check valves to prevent air being drawn in to the system when the system is running.

Hot water storage cylinders

This subject was dealt with in Unit **F/602/2884 Understand and apply domestic hot water system installation and maintenance techniques**, Learning Outcome 4, AC4.5 State the positioning requirements of components in hot water systems.

Feed and expansion cisterns

Please see **AC2.3 State the system layout features for filling and venting systems** in this unit.

Motorised valves – two port and three port mid position and diverter

For the position of motorised valves in central heating systems, please refer to Learning Outcome 2 of this unit:

- **AC2.1** Identify the working principles of central heating systems
- **AC2.2** Identify the type of central heating system from layout diagrams

Circulating pumps

The position of circulating pumps often depends on the age of the system and the system type. Many older one pipe systems have the pump positioned on the return., pulling the cooler return water back towards the boiler. Modern thinking, however, suggests that it is better to push the lighter, less dense, hot water away from the boiler by positioning the pump on the flow. This prevents:

- Excessive wear and tear on the pump, and;
- Sludge and other sediment from collecting in the pump.

Modern fully pumped systems would not work properly if the pump was positioned on the return and the vent cold feed arrangement on open vented systems dictates the position on the flow pipe. Please see diagram on page 566 – **AC2.3 State the system layout features for filling and venting systems**.

Automatic bypass valves

Please see **AC2.9 State the operating principles of central heating control components**, in this unit

Thermo-mechanical cylinder control valve

Please see **AC2.9 State the operating principles of central heating control components**, in this unit

Anti-gravity valve

Please see **AC2.9 State the operating principles of central heating control components**, in this unit

Drain valves

Please see **AC2.9 State the operating principles of central heating control components**, in this unit

Timing devices – clocks and programmers

Timeclocks and programmers are usually sited in a position of convenience for the end user. In most instances, this is the kitchen or utility area of the property. However, such is the nature of programmers that they can be positioned almost anywhere. Consideration should be given to the position of the boiler, since many boilers are now available with integrated timing devices on the boiler front facia. This would prove inadequate should the boiler be installed in a roof space or garage. In these instances, a separate timeclock/programmer positioned inside the property at a convenient location would be required.

Room thermostats

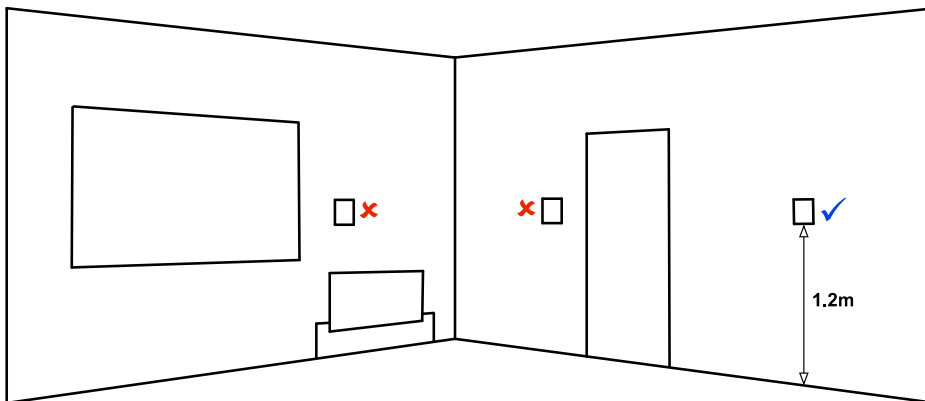

The performance of room thermostats is affected by airflow in the room. If a room thermostat is positioned incorrectly, then the airflow across it will not be representative of the airflow in the room in general and, therefore, the

temperature control effectiveness will be lost.

It is difficult to suggest the 'perfect' place for a room thermostat since all dwellings and heating systems are different, but there are definite places to avoid:

- ✗ In a room with another heat source other than a radiator, such as a cooker, gas fire or open fire etc.
- ✗ An unheated room
- ✗ A room with a radiator fitted with TRVs
- ✗ In direct sunlight
- ✗ Behind curtains
- ✗ A warm or cold draught

- ✘ Directly above or opposite a heat source or radiator
- ✘ Near electrical appliances such as TV, DVD player, PC etc.
- ✘ In the corner of two walls or the junction between wall and ceiling
- ✘ Near a door or window

In general, it is best to position a room thermostat in a heated room in the zone being controlled, where it has a free flow of air around it, preferably on an internal wall, about 1.2m above finished floor level.

Cylinder thermostats and overheat protection devices

Please see **AC2.9 State the operating principles of central heating control components**, in this unit

Frost and pipe combined thermostat

Please see **AC2.9 State the operating principles of central heating control components**, in this unit

AC5.7 Identify suitable methods for making new central heating pipework connections to components

Pipework connections to heating components and appliances are usually dictated by the manufacturer and in most cases involve either male/female screwed joints or compression fittings.

- a) **Boilers** – these generally require that copper tubes are installed from the boiler for at least 1m before any changes i.e. to plastic pressure pipe – are considered. Modern boilers have dedicated compression fittings that are designed and made by the manufacturer.
- b) **Central heating control system components** – again, like boilers, controls such as zone and diverter valves have manufacturer designed compression fittings. In some instances male or female threaded joints are needed and these can be suitably made with the correct conversion fitting and PTFE tape.
- c) **Heat emitters** – there are many forms of central heating heat emitter from radiators to underfloor heating and many have specialist connections dictated by the manufacturer. In general, radiators have ½ " female connections at all ends of the radiator. Radiator valve connections are via a male tapered thread that requires a jointing medium, usually PTFE tape or linseed oil jointing compound and hemp wrapped in a clockwise direction around the thread. A special radiator spanner or allen key is then used to wind the valve tail into the radiator. Connection to the pipework is by compression fitting method.
- d) **Hot water storage cylinders** – cylinder connections vary from manufacturer to manufacturer and this can often be regional. For example, a hot water cylinder purchased in the east midlands area of the UK will have 1" female connections for the cold feed and hot water draw-off with 1" male connections for the heat exchanger coil. A cylinder purchased in the north of the UK will probably have all connections 1" male thread.

Because of these variations, making the copper pipe on to the hot water storage cylinder will vary. For those cylinders that have all male thread connections, a straight union adapter can be used.

Where the connections are female thread, then a male thread to copper adapter will be required.

- e) **Feed and expansion cisterns** – these are supplied without any connections at all and so each F&E cistern installation will require the holes for the connections correctly positioning and cutting out using a hole saw. Cold feed connections may be made with compression-type tank connectors. The Float Operated Valve and overflow connections are made via a ½ “ tap connector and 21mm pushfit or compression overflow pipe connector respectively.

AC5.8 State how to position, fix and connect new central heating pipework to components

- a) **Panel radiators** – please refer to AC5.1 above
- b) **Boilers** - positioning, fixing and connecting to boilers is dictated by the boiler manufacturer instructions. These should be followed at all times.
- c) **Control components** – positioning, fixing and connecting to control components is dictated by the system design. Control components should be accessible in all cases for repair and/or replacement. Again, the manufacturer’s instructions will show the best position/orientation for their components and these should be followed at all times.
- d) **Hot water storage cylinders** – The siting of hot water storage cylinders is usually dependent on the property design. Cylinders are usually sited in a centrally placed airing cupboard and positioned on a small platform, raised slightly of the finished floor level. Connections to the hot water heating coil/heat exchanger are often made using straight female iron to copper straight unions.
- e) **Filling and venting components:**
 - a. **Open vented systems** – the F&E cistern should be installed in the roof space, alongside any cold water storage cistern installed. The F&E cistern should be positioned slightly lower the cold water storage cistern as shown in Learning Outcome 2, AC2.3.
 - b. **Sealed systems** – as stated earlier in the unit, the expansion vessel and temporary filling loop should be connected to the return pipe to the boiler. The pressure relief valve and gauge should be installed close to the expansion vessel. The pressure relief pipework should run directly to outside the property via a tundish.
 - c. **Automatic Air Valves** – these should be positioned at high points in the system or where there is the likelihood of air being trapped. These were discussed in Learning Outcome 2, AC2.9.

AC5.9 Identify suitable methods for making new central heating pipework connections into existing central heating circuits

The method of connecting to existing heating systems will depend entirely from what type of system it is and

the material that the pipework is made from. Existing systems can be notoriously difficult to work on, especially if the pipework is more than 40 years old. Before 1973, the imperial system of measurement was used in the UK. This meant that all pipe sizes were in inches rather than millimetres and in most cases, the sizes were not compatible with the SI system sizes. Heating systems have used a variety of materials and each one brings its own unique problems when trying to make connections to existing systems.

Existing one and two pipe systems installed in copper tubes and fittings

- **BS659 Copper tube** – Introduced in the 1950's, '659 copper tube had a much thicker wall than modern copper tube. The jointing techniques were very similar to today, with both compression and capillary fittings used extensively. Again, the sizes were imperial and so making a joint requires a special adapter fitting in most cases. ½ inch tube will fit modern 15mm tube, although it's a tight fit. ¾ inch is smaller than modern 22mm tube and so an adapter is necessary. Both capillary and compression converter fittings are available.
- **BS2871 Copper tube** – There are no problems connecting to BS2871 copper tube as all sizes are compatible with BSEN1057.

Existing one and two pipe systems installed in Low Carbon Steel

Making a connection to an existing low carbon steel pipework system is extremely difficult and may require the use of hand held, portable threading equipment. In almost all cases, it will require the installation of new unions to remove the problem having two fixed ends of pipe with little or no lateral movement in any direction, especially when teeing in to existing pipe runs for extra radiator branches. Pipe sizes are the same irrespective of age and modern pipe will fit old BS21:1985 pipe threads.

Existing microbore systems

Modern microbore systems use either 8mm or 10mm copper tubing or, if the system is installed in polybutylene plastic, 10mm plastic pressure pipe. The manifolds are usually 22mm or 28mm. These pipe sizes are easy to work with because they are current sizes still in use. Many modern systems have blanked off connections on the manifold for easy connection of new pipe runs and radiators.

With existing microbore systems, the age of the system is a good indication of the pipe sizes that were originally used. The imperial microbore pipe was 3/8 " and this is not compatible with modern microbore sizes. It is slightly smaller than 10mm. The manifolds were usually imperial ¾ " pipe. Fortunately, adapters are available to convert imperial to metric in sizes ½ " to 15mm, ¾ " to 22mm and 1" to 28mm, and so conversion from one size to the other is a simple task. However, the 3/8 " microbore pipe itself has no imperial to metric adapter, as these were discontinued many years ago. In these cases, replacement of the pipe is usually the only option available.

AC5.10 Identify the insulation requirements of central heating system components

- **Pipework** – all pipework in the roof space should be insulated in accordance with the Water Supply (water fittings) Regulations 1999 to guard against freezing. Exposed pipework in the airing cupboard should be insulated to the requirements of the Domestic Building Services Design Guide:
 - Primary circulation pipes and secondary hot water circuits should be insulated whenever they pass outside the heated living space or through voids that communicate with unheated spaces. Extra provision may be required to guard against freezing.
 - All pipework including the vent pipe, that connects to hot water storage cylinders should be insulated for at least 1m beyond its connection with the cylinder or up to the point where they become concealed i.e. under the floor or in the roof space.
 - **Cisterns** – F&E cisterns should be insulated with an insulation jacket in accordance with schedule 2 of the Water Supply (water fittings) Regulations 1999.
-

Learning Outcome 7

Know the service and maintenance requirements of central heating systems and components



There are four Assessment Criteria in this Learning Outcome:

- AC7.1.** Identify how to use manufacturer instructions and job maintenance schedules to establish the periodic servicing requirements of system components.
- AC7.2.** Identify how to carry out routine checks on central heating components and pipework systems as part of a periodic maintenance programme
- AC7.3.** State the procedures for dealing with defects in central heating components and pipework:
- AC7.4.** Identify the types of information to be provided on a maintenance record for central heating systems.

AC7.1 Identify how to use manufacturer instructions and job maintenance schedules to establish the periodic servicing requirements of system components.

The use of manufacturer's instructions was discussed in Unit **H/602/2697 - Understand and apply domestic cold water system installation and maintenance techniques**, Learning Outcome 7, AC7.1 Identify how to use manufacturer instructions and job maintenance schedules to establish the periodic servicing requirements of cold water system components.

AC7.2 Identify how to carry out routine checks on central heating components and pipework systems as part of a periodic maintenance programme

The method of carrying out checks on pipework and components was discussed in Unit **H/602/2697 - Understand and apply domestic cold water system installation and maintenance techniques**, Learning Outcome 7, AC7.2 Identify how to carry out routine checks on cold water system components as part of a periodic maintenance programme.

There are, however, components that require periodic maintenance that are specific to central heating systems and these will be discussed in turn.

- 1) Poor circulation in heat emitters/poor flow rate through the heating system** – There are a number of issues associated with poor circulation through heat emitters in heating systems and most are centred around corrosion. There are checks that can be made to diagnose the problem:
 - i) Check that the radiator valves are open. This may seem like an obvious solution but if the system has been balanced and the lockshield valve is only partially open, the valve can become blocked with debris.
-

- ii) Take a sample of water from the radiator and examine it for suspended solids or discolouration as this could indicate corrosion:
 - (1) A reddish tint to the water suggests red oxide sludge (or rust). This suggests that the system is drawing in air.
 - (2) A blackish tint to the water or suspended black particles suggests that electrolytic corrosion is taking place. These black particles are known as 'magnetite' and are small flakes of corroded steel from the radiators caused by the corrosion.
 - (3) If the water is clear, this suggests that the system is free of corrosion. However, corrosion could have taken place in the past or that the system flow rate is so poor that the water movement is not enough to keep the particles in suspension and they are settling elsewhere in the system.
 - iii) If the system is an open vented system, check that air is not being drawn down the vent pipe or that water is not being pumped over the vent. Both of these scenarios would lead to corrosion.
 - iv) Check the pump. Is it installed correctly and circulating in the correct direction?
 - v) Open all of the radiator valves and vent the radiators. Note if the problem is general or localised. Are all emitters suffering from poor circulation? It is important to check whether any radiators fail to heat up at all as this positively indicates blockage.
 - vi) Increased the pump speed to see if this improves circulation.
 - vii) Check all TRVs and motorised valves to see that they are free and are not sticking.
 - viii) Do any of the radiators have cold spots? If so, where? Cold spots on radiators indicates sludge build up.
 - ix) Do any of the radiators need regular bleeding to prevent the radiator going cold? This would indicate a build-up of hydrogen due to the corrosion process, hydrogen sulphide (due to bacterial corrosion see point 2) or a build-up of infiltrated air.
- 2) Venting of gas build up within heat emitters** – Gas build-up can be from either of two points noted above. Take care when venting radiators on existing systems, especially if the gas build-up is caused by hydrogen as it is highly flammable.
- 3) Operation of control components** – Control components such as motorised valves, timeclocks and programmers should be checked to ensure that they operating as the end user requires.
- 4) Effective operation of thermostats** – thermostats should be checked to ensure that they are operating accurately. The system should be run and temperatures checked with a digital thermometer to ensure that they shut off when the required temperature has been reached.
- 5) Operation/adjustment – system filling and venting components:**
- i) With open vented systems, check that the float operated valve is working correctly and shutting off at the required water level. Often, FOVs stick in the up (closed) position. These should be re-washed as necessary.
-

ii) With sealed systems, check that the isolation valves on the temporary filling loop are operating correctly. Also check that the EC backflow prevention device (verifiable double check valve) is operating correctly by removing the test point and checking for water.:

(1) Ensure that the system is cold and pressurised to 1 bar.

(2) Ensure that the temporary filling loop is disconnected.

(3) Remove the test point and check for water. If water is detected then the double check valve has failed and needs replacing. No water present indicates that valve is working correctly.

When these checks have been completed, ensure that the temporary filling loop is removed.

AC7.3 State the procedures for dealing with defects in central heating components and pipework

1) **Failure of control components** – most control components use electricity. Do not attempt any repairs or replacement of motorised valves, thermostats or programmers/timeclocks. These should be checked by a qualified, experienced operative.

2) **Leakage in system pipework** – Leakage in pipework will require repairing as a matter of urgency. The type of repair will depend upon the pipework material. The system must be isolated and drained before any repair can take place:

a. Isolate the electricity supply to the heating system and check for safe isolation.

b. Place a notice at the point of isolation warning that the system is off and drained and should not be turned on.

c. Turn off the water supply to the F&E cistern (open vented system) or ensure that the temporary filling loop is disconnected (sealed system).

d. Attach a hose pipe to the lowest drain point, place the open end of the hose into a suitable drain and open the drain off valve.

e. Open the upstairs air release valves on the radiators to release the water in the radiators.

f. Open the downstairs air release valves on the radiators to release the water in the radiators.

g. Once the system is drained, then the repair can be completed.

3) **Leakage from heat emitters** – Heat emitters can leak from 4 places:

a. The radiator itself, usually due to corrosion – this will require that the radiator is replaced.

b. The radiator valve – check to see where the valve is leaking from:

i. If it is the union, try tightening it up. If it is tight, then turn off the radiator, release the water, break the union and apply jointing compound or PTFE to the union face.

- ii. If it is the packing gland on the valve spindle, then carefully tighten with an adjustable spanner. Care should be exercised. Do not overtighten the packing gland or the valve will not operate.
 - c. The joints between the radiator and the valve or the radiator and the air release valve/blanking plug. These will require removing and re-sealing with PTFE tape.
 - d. The air release valve – this will require replacement. Do not overtighten or the air release pin will snap inside the valve.
 - 4) **Replacement of control valves** – electrical control valves should only be replaced by qualified experienced operatives. Remember! Electricity can kill!
 - 5) **Replacement of heat emitters** – the following points assume that the leaking radiator is being replaced by the same sized radiator. It is desirable when replacing a radiator that the radiator valves be replaced also. If this is the case then the system should be first isolated and drained as described in **point 2: Leakage from system pipework**. If the existing valves are going to be reused then follow the points below:
 - a. Sheet down the immediate area with dust sheets. This is important because old radiators often have black water and black sludge in them. This is impossible to remove if it gets on to fixtures, fittings and carpets. Protection of property is vital.
 - b. Turn off the radiator valves. If a TRV is fitted, the screwdown top to shut off the valve that came with the TRV will be required.
 - c. Release the air from the radiator. Use a cloth to catch any water.
 - d. Place a bowl under one of the radiator valve unions. Break the union and catch the water with the bowl. Have a bucket handy so that the bowl can be emptied as necessary.
 - e. Once the radiator is drained, break the other union and disconnect both radiator valves from the radiator.
 - f. Close the air release valve, remove the radiator and turn it upside down so that any remaining water falls to the bottom. Take the radiator outside where the residue water in the radiator can no longer be a problem.
 - g. Remove both radiator tails from the old radiator.
 - h. Remove the old radiator brackets from the wall, taking care not to damage any decorating/wall paper etc.
 - i. Unpack and dress the new radiator. Make sure that the old radiator tails are placed in the same position on the new radiator i.e. left radiator valve with left hand tail.
 - j. Mark the position of the new brackets on the new radiator and place the radiator in position between the radiator valves.
 - k. Transfer the bracket positions from the radiator to the wall.
-

- l. Using a spirit level, draw two vertical lines at these marks.
 - m. Turn the radiator over, place one of the new brackets in position on the radiator and measure the distance from the bottom of the bracket to the centre of the radiator tails. This is the distance that the new brackets will be fixed to the wall.
 - n. Now, measure from the centre of the union on the radiator valve the same distance on the wall and mark it.
 - o. Using a spirit level, mark a line on the wall.
 - p. Offer the radiator brackets to the wall, mark the holes and drill and fix the brackets.
 - q. If necessary, put joint compound or PTFE tape on the radiator unions and hang the new radiator on the new brackets.
 - r. Retighten both radiator valve unions.
 - s. Ensure that the air release valve is closed.
 - t. Turn on both radiator valves, open the air release valve and bleed the radiator of air. Once water is detected, close the air release valve.
 - u. Run the heating system and check that the radiator gets hot.
 - v. Recheck the whole system, re-balancing the system as required.
- 6) **Replacement of hot water storage cylinders** – This was dealt with in Unit **F/602/2884 - Understand and apply domestic hot water system installation and maintenance techniques**, Learning Outcome 6, AC6.3 State the procedures for dealing with defects in hot water components and pipework.

AC7.4 Identify the types of information to be provided on a maintenance record for central heating systems

For central heating systems, it is advisable to keep a record of all maintenance and repairs for future reference. The types of information noted should be:

- The name of the maintenance engineer
 - The date and time the maintenance/repairs were carried out
 - The type of system being maintained
 - The type, model and make of boiler installed
 - The number and position of heat emitters installed
 - The date of the last boiler service
 - Any faults with the boiler recorded
 - The type of maintenance/repairs undertaken
 - Their location
 - The materials/components or replacement parts used
-

- The location of manufacturer's instructions/maintenance data.
 - The temperature of the heat emitters
 - Any corrosion witnessed and where.
-

Advert

Now Available!

from



**Award in the Requirements
for Electrical Installations
BS7671:2018 (18th Edition)
(Level 3)**

<http://bpec.org.uk/qualification/18th-edition/>

 Find us on LinkedIn

 Follow us at @bpec1

 View us at flickr.com/bpec1

 Join us at facebook.com/bpecpage

 Watch us at youtube.com/bpec123

T: 01332 376000

E: info@bpec.org.uk

W: www.bpec.org.uk

BPEC, 1-2 Mallard Way, Pride Park, Derby, DE24 8GX

Learning Outcome 9

Know the decommissioning requirements of central heating systems and components



**System turned off.
Plumber working on the system
Do not turn on!**

There are six Assessment Criteria in this Learning Outcome:

- AC9.1.** Identify working methods that reduce the periods during which central heating systems are not available to building users.
- AC9.2.** State the information that needs to be provided to other persons before decommissioning work takes place.
- AC9.3.** State how to temporarily decommission central heating and connecting pipework systems.
- AC9.4.** Identify the work sequences for permanently decommissioning central heating and pipework systems.
- AC9.5.** Identify the procedures for safely draining and disposing of central heating system contents.
- AC9.6.** Identify the methods used during the decommissioning process to prevent the end-user from operating the appliance or system

AC9.1 Identify working methods that reduce the periods during which central heating systems are not available to building users

AC9.2 State the information that needs to be provided to other persons before decommissioning work takes place

There are instances where central heating systems must be temporarily de-commissioned to allow essential works, such as repairs, servicing and replacement of components, to be conducted. The impact of isolation means that some parts, and in a worst-case scenario, all of the system will need to be isolated. Also, ensure that all electrical components, heaters, thermostats, motorised valves etc. are correctly isolated before work begins.

There are methods we can employ to lessen the impact of isolation on the customer:

- 1)** Do as much preparation beforehand as possible. If, for instance, you are connecting an extension to the heating system or replacing an appliance or component, make the final connection to the existing pipework the last operation, so that the system is off the minimum amount of time.
- 2)** Be frank with the customer and tell them how long the system will be off. Point out that this is an estimated time and the heating will be turned back on as soon as is possible.
- 3)** Tell the customer which parts of the system you will be working on and where in the building you will be working.
- 4)** Ask the customer to collect water for drinks in saucepans and jugs and water for ablutions in a bucket. They may not be needed but at least the customer will have some water for those essential things.

Isolating heating systems can be very annoying and inconvenient to a customer, especially in winter, but most cases you will find that the customer is very understanding of the situation.

AC9.3 State how to temporarily decommission central heating and connecting pipework systems

This is where a heating system or part of a heating system is isolated and drained down so that work may be performed on it. Once the work is completed, the water will be re-filled and the system put back into operation.

The customer must be the focus when isolating heating systems. Therefore, keeping them informed of the sequence of operations allows them to make informed choices about alternative forms of heating, should they be necessary. Below is a suggested sequence of events:

- 1) Inform the customer that the water supply is going to be isolated and inform them as to how long the supply is expected to be off.
- 2) Suggest that they might like to collect some water for drinking etc, if necessary.
- 3) Isolate the electricity supply to the heating system and check for safe isolation.
- 4) Place a notice at the point of isolation warning that the system is off and drained and should not be turned on.
- 5) Turn off the water supply to the F&E cistern (open vented system) or ensure that the temporary filling loop is disconnected (sealed system).
- 6) Attach a hose pipe to the lowest drain point, place the open end of the hose into a suitable drain and open the drain off valve.
- 7) Open the upstairs air release valves on the radiators to release the water in the radiators.
- 8) Open the downstairs air release valves on the radiators to release the water in the radiators.
- 9) Once the system is drained, then the repair can be completed.

AC9.4 Identify the work sequences for permanently decommissioning central heating and pipework systems

Unlike temporary de-commissioning, permanent de-commissioning of a system literally means that the system will not be re-instated. In most instances, this will mean the complete removal of all pipework, components and appliances. The pipework should be cut back to the nearest live connection and capped to prevent stagnation of the water supply:

- 1) Isolate the water supply at the point where the system is to be decommissioned. For heating systems, this will usually be the mains cold water isolation valve connected to the Float Operated Valve to the feed and expansion cistern in the roof space or the mains cold water connection to the filling loop
 - 2) Isolate and disconnect any electrical supply at the switched fused spur and remove the 3amp fuse.
 - 3) Drain the system as discussed earlier in the unit.
 - 4) Remove all appliances, components and heat emitters and carefully remove the pipework and clips.
 - 5) Cut the pipework back to the stop valve or nearest live connection and cap the pipe off.
-

- 6) Any holes left in the building structure due to the removal of the boiler and flue should be made good.
- 7) If necessary, a notice can be left by the stop valve informing that the heating system has been permanently de-commissioned and all pipe work, appliances and controls removed.

AC9.5 Identify the procedures for safely draining and disposing of central heating system contents

Central heating water is considered to be a low risk in terms of toxicity and, as such may be discharged directly to a foul water drain. Central heating water **MUST NOT** be discharged into a surface water or top water drain as these discharge directly to a water course and the water may cause unacceptable pollution levels because of inhibitors, de-scalers or de-sludging agents that the water contains. The water authorities allow heating water to discharge into foul water drains provided the following conditions are met:

- The water must not contain glycol
- The water must discharge to a foul water drain
- The water must not contain flammable materials such as petrol, poisonous substances or any solid material that is likely to block the drain
- The flow is such that any discharge will not cause flooding.

It should be remembered that these are concessions given by the water undertakers and that section 111 of the water industry act 1991 considers it an offence to discharge anything to a sewer which will adversely affect the sewer network or water recycling centre treatment processes.

AC9.6 Identify the methods used during the decommissioning process to prevent the end-user from operating the appliance or system

This subject was covered in depth in AC9.1 to AC9.4. Please see above.

Learning Outcome 11

Know the inspection and soundness testing requirements of central heating systems and components



There are four Assessment Criteria in this Learning Outcome:

- AC11.1.** State the checks to be carried out during a visual inspection of a central heating system to confirm that it is ready to be filled with water.
- AC11.2.** State how to fill central heating systems with water at normal operating pressure and check for leakage.
- AC11.3.** Identify how to carry out a soundness test to industry requirements on central heating systems pipework and components.
- AC11.4.** Identify the actions that must be taken when inspection and testing reveals defects in central heating systems

AC11.1 State the checks to be carried out during a visual inspection of a central heating system to confirm that it is ready to be filled with water

The checks to be carried out on central systems are almost identical to the checks carried out on cold water systems and these were covered in Unit **H/602/2697 - Understand and apply domestic cold water system installation and maintenance techniques**, Learning Outcome 11, AC11.1 State the checks to be carried out during a visual inspection of a cold water system to confirm that it is ready to be filled with water. However, there are some additional checks that should be made when dealing with central heating systems:

- Check that all open ends have been capped and/or all valves and radiator valves have been isolated.
 - Check that any drain valves are closed.
 - Isolate any service valves and gate valves.
 - Check all visible joints to ensure that they have been properly made. Check that capillary joints have been wiped clean of any excess flux as this can cause corrosion in later life.
 - Check that all radiator valve unions and compression joints are tight.
 - Check that enough pipe clips have been installed and that the pipework is secure.
 - Ensure that any automatic air valves are open.
 - Ensure that a provisional fill level has been set in the F&E cistern (vented systems only).
 - Check that the F&E cistern have been installed correctly and are well supported (vented systems only).
 - Ensure that any filling loop has been connected (sealed systems only)
 - Check that cistern lids are left in place.
 - Check that the hot water storage vessel well supported and stable.
 - Ensure that the electric switched fuse spur is isolated and the fuse has been removed
 - Ensure that motorised zone valves are manually open.
 - Ensure that all radiator air release valves are closed.
-

- Check that the pump has been removed and temporarily replaced with a short piece of tubing while initial filling takes place.

AC11.2 State how to fill central heating systems with water at normal operating pressure and check for leakage

There are two filling procedures for heating systems depending on the type of system installed.

Open vented systems:

- a. Close all radiator valves and radiator air release valves before filling begins.
- b. Check the F&E cistern. Make sure that the FOV shut off level has been provisionally set and that all joints are tight.
- c. Replace the pump with a short piece of tubing. This will prevent debris from entering the pump.
- d. Open manually all motorised valves and zone valves.
- e. Check that all radiator valve unions are tight.
- f. Turn on the service valve to the F&E cistern and allow the system to fill.
- g. Filling the system should begin at the furthest radiator on the downstairs circuit. Open the radiator valves and then the air release valve until water is detected. Work backwards towards the boiler filling each downstairs radiator in turn. Filling the downstairs circuit first helps to eliminate pockets of air, which can prevent efficient circulation of the heating water. When the downstairs circuit is full, proceed to the upstairs circuit and follow the same procedure, starting with the furthest upstairs radiator.
- h. Once the system is full, allow it to stand for a few minutes.
- i. Visually check for leaks across the system. Visit each radiator and all exposed pipework.
- j. Check the water level in the F&E cistern and adjust if necessary.
- k. Drain down the entire system at each downstairs radiator. This is called the cold flush and will remove any flux residues, steel wool and swarf that entered the system during installation.
- l. Refit the pump and turn on the pump valves.
- m. Refill the system.

2. Sealed systems:

- a. Close all radiator valves and radiator air release valves before filling begins.
 - b. Connect the temporary filling loop to the system pipework.
 - c. Check the pressure in the expansion vessel at the Schrader valve to ensure it matches the manufacturers data plate.
 - d. Replace the pump with a short piece of tubing. This will prevent debris from entering the pump.
 - e. Open manually all motorised valves and zone valves.
 - f. Turn on the service valve to the Filling loop and allow the system to fill to 1bar pressure and
-

- then turn off the service valve.
- g. Filling the system should begin at the furthest radiator on the downstairs circuit. Open the radiator valves and then the air release valve until water is detected. Work backwards towards the boiler filling each downstairs radiator in turn. Filling the downstairs circuit first helps to eliminate pockets of air, which can prevent efficient circulation of the heating water. When the downstairs circuit is full, proceed to the upstairs circuit and follow the same procedure, starting with the furthest upstairs radiator. As filling progresses, the pressure in the system will fall towards zero pressure. When this happens, go back to the filling loop each time the pressure drops and fill back up to 1 bar pressure.
 - h. Visually check for leaks across the system. Visit each radiator and all exposed pipework.
 - i. Check the system water pressure at the pressure gauge.
 - j. Open the pressure relief valve to ensure that water discharges from the valve.
 - k. Drain down the entire system at each downstairs radiator. This is called the cold flush and will remove any flux residues, steel wool and swarf that entered the system during installation.
 - l. Refit the pump and turn on the pump valves.
 - m. Refill the system.

AC11.3 Identify how to carry out a soundness test to industry requirements on central heating systems pipework and components

In domestic heating installations, the pressure testing procedure of domestic heating systems closely follows that recommended in the Water Supply (water fittings) Regulations 1999 and BSEN806. These documents suggest that the method of testing is directly related to the pipework material that has been used in its installation. These tests were covered in Unit **H/602/2697 - Understand and apply domestic cold water system installation and maintenance techniques**, Learning Outcome 11, AC11.1 State the checks to be carried out during a visual inspection of a cold water system to confirm that it is ready to be filled with water.

However, central heating systems do not form part of any potable water supply or system and as such the test pressures stated do not apply.

British Standard BSEN14336: 2004: *Heating systems in buildings — Installation and commissioning of water based heating systems* is very specific with regard to the test pressures and duration used on wet central heating systems. it states:

‘The heating system shall be pressure tested to a pressure at least 30% greater than the working pressure for an adequate period, as a minimum of 2 hours duration.’

When preparing a hydraulic pressure testing, the following procedure should be applied:

- a) Blank, plug or seal off all open ends
- b) Remove vulnerable items such as the heating circulation pump
- c) Open all valves in the pipework subjected to the test

- d) Check that all high points have vents, and that these vents are closed
- e) Check that the hydraulic test bucket is functioning, has the correct range and has been recently calibrated
- f) Check that there are adequate drain cocks, a hose is available and that it will reach from the cocks to the drain

For a hydraulic pressure testing, the following procedure should be applied:

- a) When filling the system with water, 'walk' the system continuously checking for leaks by the noise of escaping air or signs of liquid leakage
- b) Release air from high points systematically up through the system
- c) When the system is full of water, raise the pressure to test pressure
- d) Should the pressure fall, check that any valves are not passing water and then 'walk' the system again checking for leaks

AC11.4 Identify the actions that must be taken when inspection and testing reveals defects in central heating systems

Inspection and testing of central heating systems can sometimes reveal problems that need rectification before the system is filled and brought into operation. Problems are always best remedied before the system is 'wetted', especially if it involves altering pipework and making leak free joints.

- a. **Dealing with systems that do not meet correct installation requirements** – this can often be the result of poor working practices or failure to understand instructions. Common problems include incorrect positioning of components such as pump, motorised zone valves and feed/vent installation problems. Where these are discovered, they must be corrected before the system is put into operation.
- b. **Remedial work associated with defective pipework bracketing** – brackets and clips do two very important jobs:
 - a. They prevent pipework movement and noise
 - b. They contribute to the overall aesthetics and job neatness.

Installing extra clips may mean the temporary movement or even removal of pipework to facilitate the clips being correctly positioned.

- c. **Remedial work associated with defective control valves** – in most instances, problems of this nature will not be found until the system is up and running. Whilst manufacturers try to ensure the quality of their components, occasionally defective parts are supplied. Where this is discovered, first contact the supplier and tell them of the problem. In most cases, they will tell you to return it and get a replacement. Sometimes it may mean contacting the manufacturers technical help line by telephone. These telephone numbers are usually included in any manufacturers literature.

- d. **Remedial work associated with leakage from pipework systems** – leakage occurs because of defective materials, fittings and poor installation practices. Where leaks are discovered, they must be rectified immediately before continuing with any tests and inspections.
-