

AUV Range-only Localization and Mapping: Observer Design and Experimental Results

Mohammadreza Bayat¹ and A. Pedro Aguiar^{1,2}

Abstract—This paper addresses the localization problem of an Autonomous Underwater Vehicle using relative range measurements to stationary beacons whose locations are also unknown. We propose an observer that under observability-like assumptions drives the estimation errors to a small neighborhood of zero (whose size depends on the noise and disturbances). The observer is designed by combining the concepts of minimum energy estimators applied to continuous processes with discrete measurements (not necessarily with a fixed sampling time), adaptive multiple models estimators, and simultaneous localization and mapping techniques. We also combine the proposed solution with a projection filter that significantly improves the performance. Experimental results with the Medusa robotic vehicle are presented and discussed.

I. INTRODUCTION

Underwater localization using acoustic signals is one of the key components in a navigation system of an autonomous underwater vehicle (AUV). Among the localization techniques based on the idea of multiple beacons/transponders, a not so conventional one but potentially interesting is to use only one beacon for localization, which is a challenging problem. One of the first works on single beacon acoustic navigation was reported in [1] for an AUV moving in horizontal plane and affected by unknown constant ocean current. Later in [2], a Synthetic Long Base-Line (SLBL) navigation algorithm was described, which makes use of a single LBL in combination with a high performance dead-reckoning navigation system. See also [3] that design an extended Kalman filter (EKF) for localization of an AUV using a single beacon. In [4], by combining the dead-reckoning information with multiple range measurements taken at different instants of time, a proved robust estimator algorithm for AUV localization in the presence of constant unknown ocean currents is presented.

The authors in [5], [6] propose and design a range only sub-sea Simultaneous Localization and Mapping (SLAM) system without prior knowledge of beacons' locations.

One of the very first results in observability of single beacon system is described in [7], where a necessary and sufficient condition for local system observability is presented. The authors in [8], [9] have investigated the observability

of the linearized single beacon navigation system. Another important study that reformulates the problem to a linear time varying (LTV) system is reported in [10], [11] where necessary and sufficient conditions on the observability are provided. Lately in [12], the authors exploited the nonlinear observability concepts of a nonlinear inter-vehicle ranging system using observability rank conditions and the results obtained are validated experimentally in an equivalent single beacon navigation scenario.

In a previous work [13], we addressed the single/multiple beacon observability analysis of the SLAM for AUV navigation using range measurements to stationary beacons. We investigated for the case that the motion of the AUV corresponds to constant linear and angular velocities expressed in the body-frame, under which conditions it is possible to reconstruct the initial state of the resulting SLAM system. We showed that the unobservable subspace \mathcal{UO} restricted to the assumption that the position of one of the beacons or the initial position of the AUV is known, contains only the zero vector with exception of a particular case where the \mathcal{UO} is composed by a finite set of isolated points.

In this paper, motivated by the above properties, we design a minimum energy observer to solve the localization problem of an AUV using relative range measurements to stationary beacons whose locations are also unknown. We show that, due to the design method, state vector of the resulting SLAM process satisfies quadratic constraints. To deal with this, we introduce a projection filter that improves significantly the performance of the proposed observer. Convergence properties of the designed observer are presented. Experimental results with the Medusa robotic vehicle are presented and discussed.

II. PROCESS MODEL

This section describes the process model of the problem of computing in real-time an estimate of the position of an AUV while simultaneously constructing a map of its surrounding. The map contains an estimate of the location of stationary acoustic modems (beacons) that provide ranging measurements to the AUV based on acoustic signal travel time. we consider two coordinate frames to formulate the process model : fixed earth or inertial coordinate frame $\{\mathcal{I}\}$, and body fixed coordinate frame $\{\mathcal{B}\}$ that is attached to the AUV and moves with respect to the coordinate frame $\{\mathcal{I}\}$. Let $({}^{\mathcal{I}}\mathbf{p}_{\mathcal{B}}, {}^{\mathcal{I}}\mathbf{R}) \in \text{SE}(3)$ be the configuration of the frame $\{\mathcal{B}\}$ with respect to $\{\mathcal{I}\}$, where ${}^{\mathcal{I}}\mathbf{p}_{\mathcal{B}}$ indicates the position of the AUV in frame $\{\mathcal{I}\}$, and ${}^{\mathcal{I}}\mathbf{R}$ its rotation matrix from

This work was supported in part by projects MORPH (EU FP7 under grant agreement No. 288704), CONAV/FCT-PT (PTDC/EEA-CRO/113820/2009), and the FCT [PEst-OE/EEI/LA0009/2011]. The first author benefited from a PhD scholarship of the Foundation for Science and Technology (FCT), Portugal.

¹Institute for Systems and Robotics (ISR), Instituto Superior Técnico (IST), Lisbon, Portugal. mabayat@isr.ist.utl.pt

²Faculty of Engineering, University of Porto (FEUP), Porto, Portugal. pedro.aguiar@fe.up.pt

$\{\mathcal{B}\}$ to $\{\mathcal{I}\}$. The equations of motion are

$$\dot{\mathcal{I}}\mathbf{p}_B = \mathcal{I}_B\mathcal{R}\boldsymbol{\nu}, \quad \dot{\mathcal{I}}\dot{\mathcal{R}} = \mathcal{I}_B\mathcal{R}S(\boldsymbol{\omega}) \quad (1)$$

where the linear and angular velocities $(\boldsymbol{\nu}, \boldsymbol{\omega} : [0, \infty) \rightarrow \mathbb{R}^3)$ are viewed as input signals to the system (1). In what follows we will use the Euler angles $\boldsymbol{\eta} = [\phi, \theta, \psi]$ to parametrize the rotation matrix. In (1), $S(\cdot)$ is a function from \mathbb{R}^3 to the space of skew-symmetric matrices $\mathbb{S} := \{M \in \mathbb{R}^{3 \times 3} : M = -M'\}$ defined for a given $\mathbf{a} \in \mathbb{R}^3$.

$$S(\mathbf{a}) := \begin{bmatrix} 0 & -a_3 & a_2 \\ a_3 & 0 & -a_1 \\ -a_2 & a_1 & 0 \end{bmatrix}$$

Consider now n stationary beacons located at unknown positions $\mathcal{I}\mathbf{q}_i$, that is,

$$\mathcal{I}\dot{\mathbf{q}}_i = 0 \quad (2)$$

For each $i \in \{1, 2, \dots, n\}$, let $r_i(t)$ be an acoustic ranging measurement acquired at time t from the i^{th} beacon. The measurement/output model is given by

$$r_i = \|\mathcal{I}\mathbf{q}_i - \mathcal{I}\mathbf{p}_B\| \quad (3)$$

$$z_i = [0, 0, 1]^T \mathcal{I}\mathbf{q}_i, \quad z_0 = [0, 0, 1]^T \mathcal{I}\mathbf{p}_B \quad (4)$$

where z_0 is the depth of the AUV that is assumed to be available (we consider the practical situation that the AUV is equipped with a depth sensor). We also consider that the location of the beacons q_i are only unknown in the horizontal plane, that is, we assume that we know the depth z_i . This is a reasonable assumption if each beacon is attached to a buoy that is at the surface or utilizes a depth cell.

Equations (1)-(4) represent the nonlinear process model of SLAM problem for the AUV-beacon configuration. From the nonlinear system (1)-(4) we will construct a new linear time varying system (LTV) with an additional algebraic condition. Next, a constrained minimum energy observer for this *equivalent* LTV system is derived.

The strategy to obtain an LTV system does not follow the ones described in [14], [15] but it is specifically tailored for our application. The idea is to view the beacons \mathbf{q}_i in body frame $\{\mathcal{B}\}$ and introduce a *virtual* beacon \mathbf{q}_0 , located at the origin of $\{\mathcal{I}\}$. Following this strategy and resorting to some of the ideas in [16], we first express \mathbf{q}_0 in $\{\mathcal{B}\}$ as

$${}^B\mathbf{q}_0 = \mathcal{I}_B\mathcal{R}'\mathcal{I}\mathbf{q}_0 - \mathcal{I}_B\mathcal{R}'\mathcal{I}\mathbf{p}_B$$

whose dynamical equation is given by

$${}^B\dot{\mathbf{q}}_0 = -S(\boldsymbol{\omega}){}^B\mathbf{q}_0 - \boldsymbol{\nu}$$

where we have used (2). To obtain the dynamics of the position of the other beacons ${}^B\mathbf{q}_i$, we introduce the vector \mathbf{p}_i that connects the virtual beacon \mathbf{q}_0 to \mathbf{q}_i . Note that $\mathcal{I}\mathbf{p}_i$ is a stationary vector, while ${}^B\mathbf{p}_i$ is in general a time dependent vector (with same magnitude of $\mathcal{I}\mathbf{p}_i$ but rotated by $\mathcal{I}_B\mathcal{R}'$). Therefore,

$${}^B\mathbf{p}_i = {}^B\mathbf{q}_i - {}^B\mathbf{q}_0, \quad {}^B\dot{\mathbf{p}}_i = -S(\boldsymbol{\omega}){}^B\mathbf{p}_i \quad (5)$$

From (3), (5), and using the fact that $\mathcal{I}\mathbf{q}_i = \mathcal{I}\mathbf{p}_B + \mathcal{I}_B\mathcal{R}'{}^B\mathbf{q}_i$, the measurement model can be written as

$$r_i = \|\mathcal{I}\mathbf{q}_i - \mathcal{I}\mathbf{p}_B\| = \|\mathcal{I}_B\mathcal{R}'{}^B\mathbf{q}_i\| = \|\mathcal{I}_B\mathbf{p}_i + \mathcal{I}_B\mathbf{q}_0\|$$

where we have used the fact that \mathcal{R} is an orthogonal matrix. Introducing the scalar state variable $\chi_i = \|\mathcal{I}_B\mathbf{p}_i + \mathcal{I}_B\mathbf{q}_0\|$, the output equation (3) becomes $r_i = \chi_i$, and the state χ_i satisfies

$$\dot{\chi}_i = \frac{-\boldsymbol{\nu}'(\mathcal{I}_B\mathbf{p}_i + \mathcal{I}_B\mathbf{q}_0)}{r_i}$$

Using the equalities, $\mathcal{I}\mathbf{q}_i = \mathcal{I}_B\mathcal{R}'{}^B\mathbf{p}_i$, and $\mathcal{I}\mathbf{p}_B = -\mathcal{I}_B\mathcal{R}'{}^B\mathbf{q}_0$ we can rewrite the output equations (4) as

$$z_i = [0, 0, 1]^T \mathcal{I}_B\mathcal{R}'{}^B\mathbf{p}_i, \quad z_0 = -[0, 0, 1]^T \mathcal{I}_B\mathcal{R}'{}^B\mathbf{q}_0$$

In summary we obtain an LTV system described by

$$\begin{cases} \dot{\mathbf{x}}(t) = A(\mathbf{u}(t), \mathbf{y}(t)) \mathbf{x}(t) + \mathbf{b}(\mathbf{u}(t)) \\ \mathbf{y}(t) = C(\mathbf{u}(t)) \mathbf{x}(t) \end{cases} \quad (6)$$

where

$$\begin{aligned} \mathbf{x} &:= [{}^B\mathbf{q}'_0, {}^B\mathbf{p}'_1, {}^B\mathbf{p}'_2, \dots, {}^B\mathbf{p}'_n, \chi_1, \chi_2, \dots, \chi_n] \\ \mathbf{y} &:= [r_1, \dots, r_n, z_0, z_1, \dots, z_n] \\ \mathbf{u} &:= [\boldsymbol{\nu}', \boldsymbol{\omega}', \boldsymbol{\eta}'] \\ \mathbf{s} &:= [1/r_1, 1/r_2, \dots, 1/r_n]' \\ A(\mathbf{u}, \mathbf{y}) &:= \begin{bmatrix} -S(\boldsymbol{\omega}) & \mathbf{0} & \mathbf{0} \\ \mathbf{0} & -I_n \otimes S(\boldsymbol{\omega}) & \mathbf{0} \\ -\mathbf{s} \otimes \boldsymbol{\nu}' & -I_n \otimes (\mathbf{s} \otimes \boldsymbol{\nu}') & \mathbf{0} \end{bmatrix} \\ \mathbf{b}(\mathbf{u}) &:= [-\boldsymbol{\nu}' \quad \mathbf{0} \quad \mathbf{0}]' \\ C(\mathbf{u}) &:= \begin{bmatrix} \mathbf{0} & \mathbf{0} & \mathbf{0} & I_n \\ -[0, 0, 1]^T \mathcal{I}_B\mathcal{R}'(\boldsymbol{\eta}) & \mathbf{0} & \mathbf{0} & \mathbf{0} \\ \mathbf{0} & I_n \otimes ([0, 0, 1]^T \mathcal{I}_B\mathcal{R}'(\boldsymbol{\eta})) & \mathbf{0} & \mathbf{0} \end{bmatrix} \end{aligned}$$

with $\boldsymbol{\omega} = [\omega_1, \omega_2, \omega_3]'$, $\boldsymbol{\nu} = [\nu, 0, 0]'$. Here, given two matrices $M_i \in \mathbb{R}^{m_i \times n_i}$, $i \in \{1, 2\}$, we denote by $M_1 \otimes M_2 \in \mathbb{R}^{m_1 n_1 \times m_2 n_2}$ the Kronecker product of M_1 by M_2 . We remark that (6) is not defined when $r_i = 0$, which corresponds to the particular case that the position of the AUV coincides with the location of the i^{th} beacon.

The observability analysis of the described system is investigated in a previous work by the authors in [13]. In summary, for constant linear and angular velocities, system (6) is observable with only range measurements if $\omega_1 \neq 0$ and $(\omega_2 \neq 0$ or $\omega_3 \neq 0)$. Combining the depth and range measurements we obtain a less conservative condition: $\omega_3 \neq -\omega_2 \tan(\phi)$. If none of these conditions are satisfied then the system is only locally observable. Notice that, due to the constraints

$$\chi_i^2 = \|\mathcal{I}_B\mathbf{p}_i + \mathcal{I}_B\mathbf{q}_0\|^2 \quad (7)$$

it can be concluded that the initial position of each beacon (assuming a prior knowledge about initial location of AUV) can be any of the elements of the unobservable subspace

$$\begin{aligned} \mathcal{UO} &= \{ {}^B\mathbf{p}_i(0) + \alpha_i [0, c\phi_0, s\phi_0]' \\ &\quad : \alpha \in \{0, -2(\bar{y}_i c\phi_0 + \bar{z}_i s\phi_0)\} \} \end{aligned} \quad (8)$$

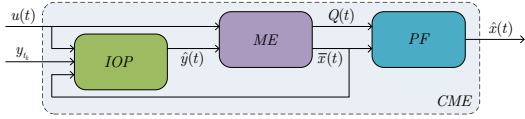

Fig. 1. Block diagram of the designed CME

where $[\bar{x}_i, \bar{y}_i, \bar{z}_i]' = \mathcal{B}\mathbf{q}_0(0) + \mathcal{B}\mathbf{p}_i(0)$ and ϕ_0 denotes the initial heading angle. For convenience, we let $s(\cdot)$, $c(\cdot)$, and $t(\cdot)$ denote $\sin(\cdot)$, $\cos(\cdot)$, and $\tan(\cdot)$ respectively.

III. OBSERVER DESIGN

Consider the continuous time system (6) corrupted with additive state disturbance $\mathbf{d}(t)$ and measurement noise $\mathbf{n}(t)$. Notice that due to practical limitations only discrete samples of observations are available.

$$\begin{cases} \dot{\mathbf{x}}(t) = A(\mathbf{u}(t), \mathbf{y}(t))\mathbf{x}(t) + B(\mathbf{u}(t)) + G(\mathbf{u}(t))\mathbf{d}(t) \\ \mathbf{y}(t_k) = C(\mathbf{u}(t_k))\mathbf{x}(t_k) + \mathbf{n}(t_k) \end{cases} \quad (9)$$

Given an initial estimate $\bar{\mathbf{x}}_0$ and the past control inputs $\{\mathbf{u}(\tau) : 0 \leq \tau \leq t\}$ and observations $\{\mathbf{y}(t_k) : t_k \in \{t_1, \dots, t_{k^*}\}\}$, where t_{k^*} is the maximum discrete time which is strictly less than t , the goal is to obtain an estimate of the state vector $\mathbf{x}(t)$ while satisfying the equality algebraic constraint (7). To this end, we propose the observer architecture depicted in Fig. 1, which will be denominated as Constrained Minimum Energy Estimator (CME). The CME is composed of the following sub-systems:

- A Minimum Energy Estimator (ME) which its role is to solve an unconstrained optimization problem (will be defined in the next subsection).
- A Projection filter (PF) which maps the unconstrained solution $\bar{\mathbf{x}}(t)$ to the constrained solution $\hat{\mathbf{x}}(t)$.
- An Inter-sample Output Predictor (IOP) which provides a continuous estimate of range data to be used by the ME estimator.

We will combine SLAM based approach in the CME design to deal with the problem of multiple but unknown number of beacons. Moreover, by taking into account the isolated elements of unobservable subspace presented in (8), we include the concept of multiple models to improve the convergence time of the proposed observer.

A. Minimum Energy Estimator (ME)

The ME estimator is formulated as an unconstrained optimization problem in a deterministic \mathcal{H}_2 filtering setting by computing the value of the state that minimizes the induced \mathcal{L}_2 -gain from the disturbances and noise to estimation error. More precisely, the state estimate $\bar{\mathbf{x}} \in \mathbb{R}^{n_s}$ is obtained from the solution of the unconstrained optimization problem

$$\bar{\mathbf{x}}(t) = \arg \min_{\mathbf{z} \in \mathbb{R}^{n_s}} J(\mathbf{z}, t)$$

where the cost function $J(\mathbf{z}, t)$ is given by

$$\begin{aligned} J(\mathbf{z}, t) = & \min_{\substack{\mathbf{d}: [0, t], \mathbf{n}(t_k) \\ k=1, 2, \dots, k^*}} \{(\mathbf{x}(0) - \hat{\mathbf{x}}_0)' Q_0 (\mathbf{x}(0) - \hat{\mathbf{x}}_0) \\ & + \int_0^t \|\mathbf{d}(\tau)\|_{R_d}^2 d\tau + \sum_{k=1}^{k^*} \|\mathbf{n}(t_k)\|_{R_n}^2 : \\ & \mathbf{x}(t) = \mathbf{z}, \dot{\mathbf{x}} = A(\mathbf{u}, \mathbf{y})\mathbf{x} + G(\mathbf{u})\mathbf{d}, \\ & \mathbf{y}(t_k) = C(\mathbf{u})\mathbf{x}(t_k) + \mathbf{n}(t_k)\} \end{aligned} \quad (10)$$

with $R_d > 0$ and $R_n > 0$ being weighting parameters on disturbance and measurement noises. Using the results of [16], [17], it can be concluded that the formulated unconstrained state estimation problem has the following exact solution

- For $t_{k-1} \leq t < t_k$, $k = 1, \dots, k^*$

$$\begin{aligned} \dot{Q}(t) = & -A(\mathbf{u}, \mathbf{y})' Q(t) - Q(t) A(\mathbf{u}, \mathbf{y}) \\ & - Q(t) G(\mathbf{u}) R_d G(\mathbf{u})' Q(t) \end{aligned} \quad (11)$$

$$\dot{\bar{\mathbf{x}}}(t) = A(\mathbf{u}, \mathbf{y})\bar{\mathbf{x}}(t) + B(\mathbf{u}) \quad (12)$$

- At $t = t_k$, $k = 1, \dots, k^*$

$$Q(t_k) = Q(t_k^-) + C(\mathbf{u})' R_n^{-1} C(\mathbf{u})$$

$$\bar{\mathbf{x}}(t_k) = \bar{\mathbf{x}}(t_k^-) - Q(t_k)^{-1} C(\mathbf{u})' R_n^{-1} (C(\mathbf{u})\bar{\mathbf{x}}(t_k^-) - y(t_k))$$

while satisfying initial conditions $Q(0) = Q_0 > 0$, $\bar{\mathbf{x}}(0) = \bar{\mathbf{x}}_0$.

B. Projection Filter (PF)

The solution obtained from the unconstrained state estimation problem, $\bar{\mathbf{x}}(t)$, does not necessarily satisfy the equality algebraic constraint (7). Notice that (7) can be rewritten in a quadratic constraint form $\mathbf{z}' S_i \mathbf{z} = 0$. Thus, the idea is to compute $\hat{\mathbf{x}}$ such that

$$\hat{\mathbf{x}}(t) = \arg \min_{\substack{\mathbf{z} \in \mathbb{R}^{n_s} \\ \forall i \in \{1, \dots, n\}}} (\mathbf{z} - \bar{\mathbf{x}})' Q (\mathbf{z} - \bar{\mathbf{x}}) \quad (13)$$

Since (13) does not have a closed-form expression, following the ideas in [17], [18] we propose to solve the related sufficient Karush-Kuhn-Tucker (KKT) conditions asymptotically. More precisely, consider the corresponding Lagrangian function

$$\mathcal{L}(\hat{\mathbf{x}}, \boldsymbol{\lambda}) = (\hat{\mathbf{x}} - \bar{\mathbf{x}})' Q (\hat{\mathbf{x}} - \bar{\mathbf{x}}) + \sum_{i=1}^n \lambda_i \hat{\mathbf{x}}' S_i \hat{\mathbf{x}}$$

where $\boldsymbol{\lambda} \in \mathbb{R}^n$ is the Lagrange multiplier vector. This leads to the following sufficient KKT conditions for optimality

$$\mathbf{e}_2(t) = \bar{Q}\hat{\mathbf{x}} - Q\bar{\mathbf{x}} = 0, \quad \mathbf{e}_3(t) = \bar{S}(\hat{\mathbf{x}})' \hat{\mathbf{x}} = 0 \quad (14)$$

where $\bar{Q} = Q + \sum_{i=1}^n \lambda_i S_i$ and $\bar{S}(\hat{\mathbf{x}}) = [S_1 \hat{\mathbf{x}}, \dots, S_n \hat{\mathbf{x}}]$. Now defining a positive scalar constant μ , given initial condition $\hat{\mathbf{x}}(0) = \bar{\mathbf{x}}_0$, and suppose that along trajectories of the system we have $\bar{Q} > 0$ and $\bar{S}(\hat{\mathbf{x}})$ remains full column rank, the following proposed solution guaranties that the sufficient KKT conditions (14) would hold at sampling times $t = t_k$ and asymptotically in $[t_{k-1}, t_k)$, (i.e., $\mathbf{e}_2, \mathbf{e}_3 \rightarrow 0$ as $t_k \rightarrow \infty$).

- For $t_{k-1} \leq t < t_k$, $j = 1, \dots, k^*$

$$\begin{bmatrix} \dot{\hat{\mathbf{x}}} \\ \dot{\boldsymbol{\lambda}} \end{bmatrix} = \begin{bmatrix} \bar{Q} & \bar{S}(\hat{\mathbf{x}}) \\ \bar{S}(\hat{\mathbf{x}})' & 0 \end{bmatrix}^{-1} \left(\begin{bmatrix} -\dot{Q}\hat{\mathbf{x}} + Q\dot{\hat{\mathbf{x}}} + \dot{Q}\bar{\mathbf{x}} \\ 0 \end{bmatrix} - \mu \begin{bmatrix} Q(\hat{\mathbf{x}} - \bar{\mathbf{x}}) + \bar{S}(\hat{\mathbf{x}})\boldsymbol{\lambda} \\ \frac{1}{2}\bar{S}(\hat{\mathbf{x}})'\hat{\mathbf{x}} \end{bmatrix} \right)$$

- At $t = t_k$, $k = 1, \dots, k^*$

$$\begin{bmatrix} \hat{\mathbf{x}}(t_k) \\ \boldsymbol{\lambda}(t_k) \end{bmatrix} = \begin{bmatrix} \bar{Q}^{-1}(t_k)Q(t_k)\bar{\mathbf{x}}(t_k) \\ \boldsymbol{\lambda}^*(t_k) \end{bmatrix}$$

where $\boldsymbol{\lambda}^*(t_k)$ is given by solving $\mathbf{f}(\boldsymbol{\lambda}, t_k) = 0$ using iterative generalized Newton's method, with

$$f_i(\boldsymbol{\lambda}, t_k) = \bar{\mathbf{x}}'Q\bar{Q}^{-1}S_i\bar{Q}^{-1}Q\bar{\mathbf{x}}, \quad i \in \{1, 2, \dots, n\}$$

C. Inter-sample Output Predictor (IOP)

The observation $\mathbf{y}(t)$ used in (11)-(12) requires the assumption that the output of the system is a piecewise continuous signal in time, which is not (it is a discrete signal). To solve this, we could just hold $\mathbf{y}(t)$ between the two consecutive sample times (t_{k-1}, t_k) , however, it may introduce significant model mismatch if the inter-arrival time $t_{k+1} - t_k$ is not small enough. To minimize this model mismatch, we suggest the use of an inter-sample output predictor, *e.g.*, as the one pointed out in [19], where for a general nonlinear system

$$\dot{\mathbf{x}} = f(\mathbf{x}, \mathbf{u}), \quad \mathbf{y} = h(\mathbf{x}, \mathbf{u})$$

the idea consists of using the predicted output given by

$$\dot{\hat{\mathbf{y}}}(t) = L_f h(\hat{\mathbf{x}}(t), \mathbf{u}) \quad \forall t \in [t_{j-1}, t_j], \quad \hat{\mathbf{y}}(t_j) = \mathbf{y}(t_j)$$

Here, the signals $r_i(t)$ in $A(\mathbf{u}, \mathbf{y})$ will be replaced by $\hat{r}_i(t)$ (shown in Fig. 1), which according to (9) is governed by

$$\dot{\hat{r}}_i(t) = -\frac{\boldsymbol{\nu}'(\mathcal{B}\mathbf{p}_i + \mathcal{B}\mathbf{q}_0)}{\hat{r}_i(t)} \quad \forall t \in [t_{k-1}, t_k], \quad \hat{r}_i(t_k) = r_i(t_k)$$

D. SLAM Adaption

In the standard ME formulation, it is considered that the size of the state \mathbf{x} is fixed. This is not the case in SLAM where new state estimates $\hat{\mathbf{x}}$ (and corresponding Q matrix) are augmented as new features (beacons here) are discovered. Standard procedure of a SLAM algorithm can be decomposed in the following steps:

- 1) Predict the state estimate $\hat{\mathbf{x}}$ and corresponding Q matrix using the process model, the input signal \mathbf{u} , and the predicted ranges \hat{r} .
- 2) Augment new beacons' states to the state vector followed by augmenting new terms to the Q matrix.
- 3) Update current state estimate and Q matrix using measurements available from features (beacons here).

At initial time, the states $\bar{\mathbf{x}}$, $\hat{\mathbf{x}}$ are initialized by $\hat{\mathbf{x}}(t_0) = \bar{\mathbf{x}}(t_0) = [0, 0, 0]'$, which is the local initial position of the AUV if we assume that we set an anchor based on initial location of the AUV. As soon as a new beacon $\mathbf{q}_i \in \mathbb{R}^3$ at time t_k is detected, a new pair of state variables $(\mathcal{B}\hat{\mathbf{p}}_i(t_k), \bar{\chi}_i(t_k))$ is constructed as follows

$$\mathcal{B}\hat{\mathbf{p}}_i(t_k) = -\mathcal{B}\hat{\mathbf{q}}_0(t_k) + \mathcal{R}(0, \alpha_2, \alpha_3)[r_i(t_k), 0, 0]' \quad (15)$$

$$\bar{\chi}_i(t_k) = r_i(t_k) \quad (16)$$

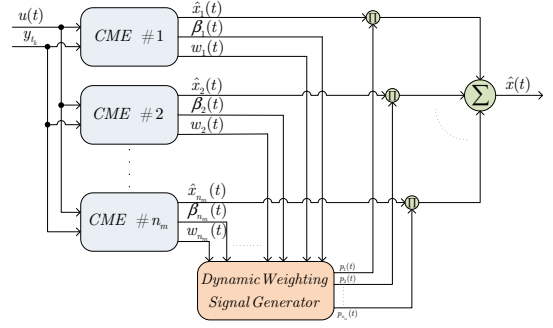

Fig. 2. Block diagram of the designed MMAE.

where $\alpha_2 \in [-\frac{\pi}{2}, \frac{\pi}{2}]$ and $\alpha_3 \in [-\pi, \pi]$ are unknown parameters rotating the vector $[r_i(t_k), 0, 0]'$, and at this stage they can be chosen arbitrarily. The new pair of state variables (15)-(16) is then augmented into the state vectors $\bar{\mathbf{x}}$ and $\hat{\mathbf{x}}$. The matrix Q is updated with new terms according to

$$Q(t_k) := \begin{bmatrix} Q(t_k) & \mathbf{0} & \mathbf{0} \\ \mathbf{0} & (r_i^2(t_k)I_3 + Q_v^{-1}(t_k))^{-1} & \mathbf{0} \\ \mathbf{0} & \mathbf{0} & \sigma_{r_i}^{-2} \end{bmatrix}$$

where the term $Q_v(t_k)$ can be interpreted as the information matrix (if the problem was stochastic) of the position $\mathcal{B}\hat{\mathbf{q}}_0(t_k)$ and $\sigma_{r_i}^2$ describes the uncertainty of range measurement of beacon i . Notice that if the system (9) is observable in $[t_0, t_f]$ then initializing the CME with arbitrary chosen α, β will result in the solution $\hat{\mathbf{x}}(t)$ that converges to $\mathbf{x}(t)$.

E. Multiple Model Aided SLAM

The process model (6) constrained by (7) is locally observable in $[t_0, t_f]$ for some classes of inputs [13]. In this case, the proposed CME initialized with $\bar{\mathbf{x}}(0)$ converges to the closest element of \mathcal{UO} (8). This motivates the need to use a multiple model approach. The fact is that as long as the system is locally observable, both elements of (8) are valid solutions. However, as soon as the system becomes observable, the set of possible solutions shrinks to only one of them. This means that the observer initialized with any initial condition converges (as will be shown in the next section) to the true solution, but notice that the time of convergence depends on how far is the initial condition from the true solution ($\|\hat{\mathbf{x}}(0) - \mathbf{x}(0)\|$). In this case, to reduce the convergence time we propose to use a Multiple Model Adaptive Estimator (MMAE) scheme as shown in Fig. 2. Each CME is an observer initialized with a different initial condition and a weight signal $p_s(t)$ assigned to it. The weights are evaluated and updated according to

$$p_s(t_k) = \frac{p_s(t_{k-1})\beta_s(t_k)e^{-\frac{1}{2}w_s(t_k)}}{\sum_{l=1}^{n_m} p_l(t_{k-1})\beta_l(t_k)e^{-\frac{1}{2}w_l(t_k)}}, \quad s \in \{1, \dots, n_m\}$$

where $p_s(t_k)$ is weight of the s^{th} model at time t_k , and

$$\begin{aligned}\beta_s(t_k) &= \det(\mathcal{S}_s(t_k))^{-\frac{1}{2}} \\ w_s(t_k) &= \|\hat{\mathbf{y}}_s(t_k^-) - \mathbf{y}(t_k)\|_{\mathcal{S}_s(t_k)}^{-1} \\ \mathcal{S}_s(t_k) &= C(\mathbf{u}(t_k))Q^{-1}(t_k)C'(\mathbf{u}(t_k)) + R_n\end{aligned}$$

Given the range measurement from newly observed beacon i at time t_k , we generate two initial conditions ${}^B\bar{\mathbf{p}}_i(t_k)$ which satisfy constraint (7), using (8) and an arbitrary chosen $[\bar{x}_i, \bar{y}_i, \bar{z}_i]'$ (typically set to $[0, r_i(t_k), 0]'$ + ${}^B\bar{\mathbf{q}}_0(t_k)$). Two new sets of models are created and each initial condition is augmented to the states vector of the model. Then, we apply a MMAE scheme with n_m models with the weights $p_s(\cdot) \geq 0$ initialized equally, such that the sum of all equals to 1 [20]. Whenever one of the models' weights p_s has reached some threshold near 1, the corresponding model will be kept and all the other models are discarded.

IV. OBSERVER CONVERGENCE

In what follows we present required conditions for the convergence of the designed observer's estimation error to a neighborhood around zero (or zero without presence of the noise and disturbances). Due to space limitations, the proofs are omitted. Consider the following assumptions:

Assumption 1: The matrix \bar{Q} introduced in (14) is positive definite along trajectories of the CME and $\bar{S}(\hat{\mathbf{x}})$ remains full column rank. \square

Assumption 2: Let $Num(t, \sigma)$, $0 \leq \sigma < t$ denote the number of time instants at which measurement arrive in the open interval (σ, t) . There exist finite positive constants τ_D and N_0 , for which $Num(t, \sigma) \leq N_0 + \frac{t-\sigma}{\tau_D}$ holds. The constant τ_D is called the average dwell-time and N_0 the chatter bound. \square

Notice that Q is always positive definite but it is bounded below (implying $\lambda_{min}(Q) > 0$) only as long as the system is observable, that is, at least one of the observability conditions in [13] must hold. This implies that for λ sufficiently small $\bar{Q} > 0$. Also, the rank condition on $\bar{S}(\hat{\mathbf{x}})$ is the standard condition in Lagrange multiplier theory for constraints independence which is true here since each constraint is imposed on a different beacon. Assumption 2 guarantees that the summation of $\|\mathbf{n}\|^2$ in (10) will not grow unbounded due to too frequent measurements. This assumption is purely technical and is need to simplify the analysis. In practice it always holds.

The next result shows the convergence properties of the proposed CME observer.

Theorem 1: Suppose that Assumptions 1-2 hold, then given input/output pair $\mathbf{u}(t)/\mathbf{y}(t_k)$ of the system (9), there exist a class \mathcal{KL} function β and class \mathcal{K} functions γ_d, γ_n such that

$$\begin{aligned}\sum_{l=1}^3 \|\mathbf{e}_l(t)\| &\leq \sum_{l=1}^3 \beta_l(\|\mathbf{e}_l(0)\|, t) + \\ &\gamma_d\left(\sup_{\tau \in [0, t]} \|\mathbf{d}(\tau)\|\right) + \gamma_n\left(\sup_{\tau \in [0, t]} \|\mathbf{n}(\tau)\|\right)\end{aligned}$$

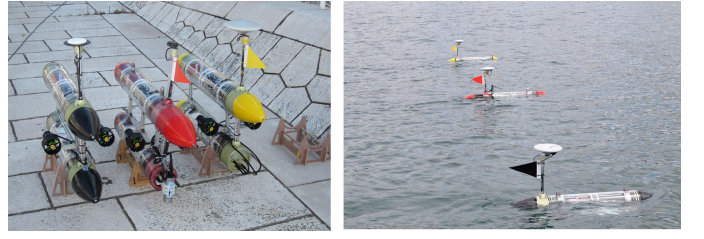

Fig. 3. The three Medusa marine robotic vehicles.

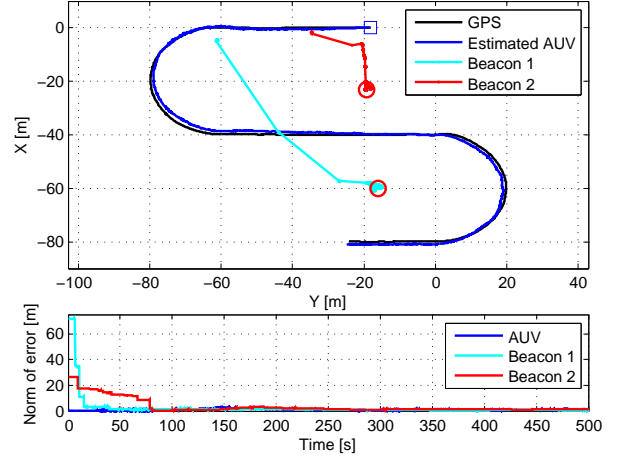

Fig. 4. Trajectory of AUV, beacons locations and corresponding estimation errors.

holds with $\mathbf{e}_1(t) = \bar{\mathbf{x}}(t) - \mathbf{x}(t)$ and $\mathbf{e}_2, \mathbf{e}_3$ defined in (14). Moreover the sufficient KKT conditions (14) hold pointwise at t_k and asymptotically in $[t_{k-1}, t_k)$ (in the sense that they hold when $t_k \rightarrow \infty$), which implies that $\hat{\mathbf{x}}(t)$ satisfies the equality algebraic constraint (7). \square

Remark 1: Consider system (9) without disturbance $\mathbf{d}(t)$ and noise $\mathbf{n}(t)$. In this case it can be concluded that as $t \rightarrow \infty$ the functions $V_1(t), V_2(t) \rightarrow 0$ implying that $\bar{\mathbf{x}}(t) \rightarrow \mathbf{x}(t)$, $\bar{S}(\hat{\mathbf{x}}(t))' \hat{\mathbf{x}}(t) \rightarrow 0$ and it follows that $\|\hat{\mathbf{x}} - \bar{\mathbf{x}}\|_Q^2 \rightarrow 0$. Since Q is a positive definite matrix, this implies that $\hat{\mathbf{x}}(t) \rightarrow \bar{\mathbf{x}}(t)$ which concludes that $\hat{\mathbf{x}}(t) \rightarrow \mathbf{x}(t)$. \square

V. EXPERIMENTAL RESULTS

In this section we describe experimental results that were done with the three autonomous surface vehicles (Medusas) which are developed at the Laboratory of Robotics and Systems in Engineering and Science (LARSyS) of the Instituto Superior Técnico (IST), Lisbon (see Fig. 3). Each vehicle has two side thrusters that can be independently controlled, equipped with IMU, GPS, and compass. The communications with other devices are done via wifi or an underwater acoustic modem (Tritech Micron Data Modem). In this scenario, two of the Medusa vehicles have been in hold position mode to act only as stationary beacons and third one was required to follow a lawn mowing type trajectory where the condition $\omega_3 = -\omega_2 \tan(\phi)$ holds except when the AUV is turning. The inter-arrival time of range/depth measurements from each beacon was fixed to 4 seconds. Notice that the proposed observer requires $\bar{Q} > 0$

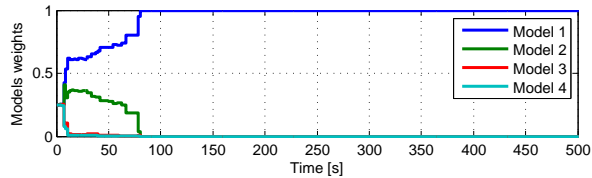

Fig. 5. Time evolution of the models' weights.

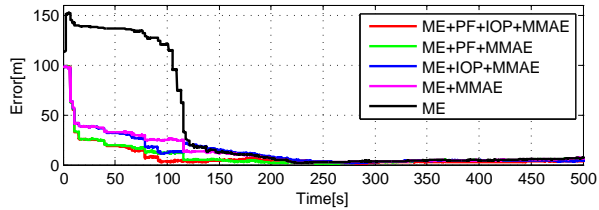

Fig. 6. Comparison of different methods using the data shown in Fig. 4.

in Assumption 1. Since each CME is initialized such that equality constraints (7) hold, this assumption is satisfied initially and verified along time.

Fig. 4 shows the constrained estimate $\hat{x}(t)$ and the true trajectory of the moving Medusa obtained by GPS. The location of the beacons are shown by (o). The moving Medusa starts from the initial position (□) on a straight line. As soon as the Medusa turns, the observability condition holds and the estimation errors converge to a small neighborhood of zero. Models' weights p_s are shown in Fig. 5 where the weight corresponding to the observer with the closest initial condition converges to 1 as soon as the required observability condition is met.

In Fig. 6 we compare the affect of disabling one or some of the designed blocks. We consider 5 observers: i) Full designed observer consisting of the ME, IOP, PF, and MMAE; ii) Observer without the IOP module; iii) Observer without using the PF module, which solves the unconstrained problem. iv) Observer with only the ME and the MMAE module; v) Plain ME observer. As expected, the fact of taking into account the quadratic constraint together with the IOP and the MMAE along with the minimum energy observer improves significantly the convergence and behavior of the estimation error during the transient time when compared with the unconstrained ME observer.

VI. CONCLUSIONS

We have addressed the observer design for the SLAM problem of an AUV equipped with inertial sensors, an acoustic ranging device to obtain relative range measurements to stationary beacons and with the possibility of using also depth sensors. We have derived an observer to reconstruct the initial state of the resulting SLAM system (and in particular the position of the AUV). The convergence properties of the designed observer showed that we can achieve global convergence to a bounded error while without presence of disturbance and noise the estimation error converges to zero. Experimental results with the Medusa robotic vehicle validated the theoretical results.

ACKNOWLEDGMENT

We gratefully acknowledge the DSOR team for their efforts in the development of the MEDUSA vehicles and their support and collaboration on the planning and execution of our sea trials, especially J. Botelho, P. Góis, J. Ribeiro, M. Rufino, L. Sebastião, and J. Soares. We would also like to express our sincere gratitude to António M. Pascoal for his constant support, enthusiasm, and encouragement for our research.

REFERENCES

- [1] A. P. Scherbatyuk, "The AUV positioning using ranges from one transponder LBL," in *MTS/IEEE. Conference on Challenges of Our Changing Global Environment OCEANS '95.*, vol. 3, pp. 1620–1623, Oct. 1995.
- [2] M. B. Larsen, "Synthetic Long Baseline Navigation of Underwater Vehicles," in *OCEANS, IEEE/MTS Conf. and Exhibition*, 2000.
- [3] T. Casey and J. Hu, "Underwater Vehicle Positioning Based on Time of Arrival Measurements from a Single Beacon," in *OCEANS, IEEE/MTS Conf. and Exhibition*, (Vancouver, BC, Canada), pp. 1–8, 2007.
- [4] J. Saude and A. P. Aguiar, "Single Beacon Acoustic Navigation for an AUV in the presence of unknown ocean currents," in *IFAC Conf. Manoeuvring and Control of Marine Craft (MCMC)*, 2009.
- [5] P. Newman and J. Leonard, "Pure range-only subsea SLAM," in *IEEE Int. Conf. on Robotics and Automation (ICRA)*, pp. 1921–1926, 2003.
- [6] E. Olson, J. J. Leonard, and S. Teller, "Robust Range-Only Beacon Localization," *IEEE Journal of Oceanic Engineering*, vol. 31, no. 4, pp. 949–958, 2006.
- [7] T. L. Song, "Observability of Target Tracking with Range-Only Measurements," *IEEE Journal of Oceanic Engineering*, vol. 24, pp. 383–387, July 1999.
- [8] A. S. Gadre and D. J. Stilwell, "Underwater navigation in the presence of unknown currents based on range measurements from a single location," in *American Control Conference (ACC)*, 2005.
- [9] A. S. Gadre, *Observability Analysis in Navigation Systems with an Underwater Vehicle Application*. PhD thesis, Virginia Polytechnic Institute and State University, 2007.
- [10] P. Batista, C. Silvestre, and P. Oliveira, "Single Beacon Navigation: Observability Analysis and Filter Design," in *American Control Conference (ACC)*, 2010.
- [11] P. Batista, C. Silvestre, and P. Oliveira, "Single range aided navigation and source localization: Observability and filter design," *Systems & Control Letters*, vol. 60, no. 8, pp. 665–673, 2011.
- [12] F. Arrichiello, G. Antonelli, A. P. Aguiar, and A. Pascoal, "Observability metric for the relative localization of AUVs based on range and depth measurements: Theory and experiments," in *IEEE/RSJ Int. Conf. on Intelligent Robots and Systems (IROS)*, 2011.
- [13] M. Bayat and A. P. Aguiar, "Observability Analysis for AUV Range-only Localization and Mapping: Measures of Unobservability and Experimental Results," in *IFAC Conference on Manoeuvring and Control of Marine Craft (MCMC)*, 2012.
- [14] A. J. Krener and A. Isidori, "Linearization by output injection and nonlinear observers," *Systems&Control Letters*, vol. 3, pp. 47–52, 1983.
- [15] F. Plestan and A. Glumineau, "Linearization by generalized input-output injection," *Systems&Control Letters*, vol. 31, pp. 115–128, 1997.
- [16] A. P. Aguiar and J. P. Hespanha, "Minimum-Energy State Estimation for Systems with Perspective Outputs," *IEEE Transactions on Automatic Control*, vol. 51, pp. 226–241, Feb. 2006.
- [17] A. P. Aguiar and J. P. Hespanha, "Minimum-energy State Estimation for Systems with Perspective Outputs and State Constraints," in *IEEE Conference on Decision and Control (CDC)*, 2003.
- [18] D. Simon and T. L. Chia, "Kalman filtering with state equality constraints," *IEEE Transactions on Aerospace and Electronic Systems*, vol. 38, pp. 128–136, Jan. 2002.
- [19] I. Karafyllis and C. Kravaris, "From Continuous-Time Design to Sampled-Data Design of Observers," *IEEE Transactions on Automatic Control*, vol. 54, pp. 2169–2174, Sep. 2009.
- [20] Y. Bar-Shalom, T. Kirubarajan, and X.-R. Li, *Estimation with Applications to Tracking and Navigation*. New York, NY, USA: John Wiley & Sons, Inc., 2002.