

Review

## Effect of Loads and Other Key Factors on Oil-Transformer Ageing: Sustainability Benefits and Challenges

Radu Godina <sup>1</sup>, Eduardo M. G. Rodrigues <sup>1</sup>, João C. O. Matias <sup>1</sup> and João P. S. Catalão <sup>1,2,3,\*</sup>

<sup>1</sup> University of Beira Interior, R. Fonte do Lameiro, Covilha 6201-001, Portugal;  
E-Mails: radugodina@gmail.com (R.G.); erodrigues0203@gmail.com (E.M.G.R.);  
matias@ubi.pt (J.C.O.M.)

<sup>2</sup> Faculty of Engineering of the University of Porto, R. Dr. Roberto Frias, Porto 4200-465, Portugal

<sup>3</sup> INESC-ID, Instituto Superior Técnico, University of Lisbon, Av. Rovisco Pais, 1,  
Lisbon 1049-001, Portugal

\* Author to whom correspondence should be addressed; E-Mail: catalao@ubi.pt;  
Tel.: +351-275-329-914; Fax: +351-275-329-972.

Academic Editor: Chang Sik Lee

Received: 4 August 2015 / Accepted: 16 October 2015 / Published: 27 October 2015

---

**Abstract:** Transformers are one of the more expensive pieces of equipment found in a distribution network. The transformer's role has not changed over the last decades. With simple construction and at the same time mechanically robust, they offer long term service that on average can reach half a century. Today, with the ongoing trend to supply a growing number of non-linear loads along with the notion of distributed generation (DG), a new challenge has arisen in terms of transformer sustainability, with one of the possible consequences being accelerated ageing. In this paper we carefully review the existing studies in the literature of the effect of loads and other key factors on oil-transformer ageing. The state-of-the-art is reviewed, each factor is analysed in detail, and in the end a smart transformer protection method is sought in order to monitor and protect it from upcoming challenges.

**Keywords:** energy; distribution network; load; transformer; sustainability

---

## 1. Introduction

The transmission and distribution systems existing today are much more far-reaching and extensive and are significantly dependent on transformers, which in turn are considerably more efficient and sustainable than those of a century ago [1]. Nevertheless, a large population of power transformers alongside with other power system grid infrastructures have been in service for decades and are considered to be in their final ageing stage. Contrariwise, due to the economic and business growth in our era, electricity demand is rising quickly [2]. The power transformer is the one of the most important as well as one of the most costly elements in the electricity grid. Effective transmission and distribution of electricity through different voltage levels is only possible through the use of power transformers. Any malfunction of this element may affect the reliability of the entire network and could have considerable economic impact on the system [1,3–5]. As a result, methods to mitigate the ageing and loss-of-life (LOL) of the transformer are intensely researched in order to make more sustainable this essential part of electric network, and consequently, to ensure the sustainability of the whole system.

Skilled planning and correct controlling needs to be taken into account with the aim of using power transformers with efficiency. Generally, transformers are designed to function within their nameplate ratings, yet, in certain situations, they are loaded over the nameplate ratings due to a failure or fault in the power system, the existence of possible contingencies on the transmission lines and/or economic considerations [6,7]. However, in order to support the overloading of the existing transformers the installation of an extra transformer is not needed. Yet, when the power transformer is overloaded beyond its nameplate ratings there are risks and consequences which can originate failures as a result. If the overloading is not operated with the proper evaluation it may cause damage and failures which are not always easily apparent. Such type of failures can be classified as short-term and/or long-term failures. One of the main consequences of overloading power transformers is their accelerated aging [6,8–10].

By overloading power transformers an increase of operation temperature is caused. It is a recognised fact that the aging of power transformers is influenced by the operating temperature [6,7,11,12]. Since the operating temperature varies according to the loading of a transformer, a model was developed for the heat transfer characteristics between oil and windings, with the purpose of predicting the hot-spot temperature ( $\theta_h$ ) in the transformer as a function of the load, while taking the cooling characteristics into account. An accurate modelling of  $\theta_h$  is decisive to precisely predict transformer aging [13].

The integrity evaluation of the transformer is complex but indispensable to avoid permanent damages with consequent substantial impacts on transmission and distribution network services and on maintenance costs as a result of outages. The accelerated degradation of its solid insulating system *i.e.*, oil impregnated cellulosic insulation materials, is among the causes which can result in transformer failures (*i.e.*,  $\theta_h$  rise over the limits, partial discharges) and strongly depends on the operating conditions of the transformer. In fact, at times the degradation of transformer's dielectric parts starts much earlier than the intended end-of-life of the transformer, which is generally predicted as being 30 years [11,12]. This can occur due to an accelerated thermal aging of both the insulating paper and oil. Despite the fact that the regeneration of a degraded insulating oil can be effectuated by appropriate treatments or even by the exchange with a new compatible oil, the restoration of degraded paper entails costly and invasive operations that have to be primarily performed by the manufacturer, since it might require the total replacement of the transformer windings. Consequently, generally the end of useful

life of a transformer is largely dependent on the thermal deterioration of its insulation papers and an accurate monitoring of parameters related to this process is essential for utilities to verify the condition of transformers [4].

Generally, due to the low load factor and other requirements, the operation efficiency of power transformers is poor and thus unsustainable. They are traditionally designed and operated with loadings between 40% and 60% in order to ensure reliability during contingencies [14]. For example, approximately 25% of distribution assets in the United States of America are used only for 440 h of peak load [15]. Additionally, due to the load growth, at substations an upgrade of power transformers is needed. The traditional method which consists in the reinforcement due to an increasing load is highly costly. Consequently, utilities tend to intensify the utilisation of already installed assets which results in highly utilised systems [16]. As a result, new solutions for load modification in the grid need to be implemented during contingencies in order to mitigate the LOL. Therefore, transformer utilisation efficiency can be increased and economic savings can be accomplished in terms of postponed reinforcements and thus, the overall sustainability is increased as well [15].

In this paper a survey of the available literature on the factors that influence the insulating paper and oil ageing, such as the electric vehicles (EVs), harmonics, ambient temperature ( $\theta_a$ ), demand response (DR), distributed generation (DG) and experimental loads created specifically to study the impact on the transformer is made. This paper is organized in five sections as follows: Section 2 explores the mathematical formulation behind the  $\theta_h$  and the paper and oil insulation ageing. In Section 3 the literature is revised and each of the factors that influence the transformer ageing are thoroughly analysed. Section 4 presents the aspects of protection of the transformer, particularly a  $\theta_h$  relay. Finally, Section 5 concludes the study.

## 2. State of the Art

When transformers operate they tend to generate quantities of heat. The conversion of the energy inside the transformer is the reason for this heat. The generated heat varies with the load that is applied to the transformer. The higher the load, the higher will be the generated heat, which is due to the copper windings and also due to the core losses that occur during the operation of the transformer [3]. The generation of heat cannot be avoided and consequently there is a standard limit that is given to a particular transformer in regard to the rise in the heat. The aforementioned limit varies from transformer to transformer and depends on the material that is utilised in the transformer. The standardised safety regulations and the thermal dependency of other elements that are adjacent to the transformer and work along with it also have to be taken into consideration. Different cooling elements exist today that are utilised to regulate the heating of the transformer. Consequently, transformers can be classified into different types based on their insulation material and cooling process [17].

The primary classification would be according to the thermal insulation material and one type is the oil filled transformers which use mineral based oil and cellulose paper in their insulation. Such types of transformers are usually inexpensive and they have varied applications. The use of oil as insulation material has proven to be very thermally efficient and to display unique dielectric properties, leading to the fact most of the remaining transformer designs being made keep oil-filled ones as reference [18].

However, oil-filled transformers display an evident weakness which is their flammability, consequently there extreme caution should be taken when such transformers are installed and maintenance operations are performed. Oil-transformers are thus generally restricted to outdoor installations and their indoor installations have to be monitored with great caution [3].

The second classification based on thermal insulation is the dry category of transformers which do not make use of mineral oil for their insulation. The most common means of insulation of this type of transformers is to use a moisture resistant polyester sealant. Most often the highest quality of this type of transformers is achieved through the use a sealant that is applied with a process known as the vacuum pressure impregnation [19]. Transformers manufactured with this method will display high resistance to chemical contaminants. On the other hand, the performance of dry transformers under overload is limited and in such conditions the temperatures usually peak sharply above the standardised temperature range. For dry transformers in order to perform over the rated load, additional cooling fans have to be installed with the purpose to accelerate the dissipation of heat through forced convection [1].

## 2.1. Types of Transformers

### 2.1.1. Small Distribution Transformers

Single phase transformers are typically made with a wound core system and rectangular windings. Such types of transformers are usually found in use in the British Standard countries and in the USA and particularly adapted for small power systems. The power range usually varies from 50 to 200 kVA within 35 kV and they represent an economical option for certain networks, particularly those with low population densities. The main advantages are the low production cost and with the possibility of good automation [20].

### 2.1.2. Distribution Transformers

These three phase transformers are immersed in liquid oil as dielectric insulation and enclosed in a tank with a cooling system and recently they are being built hermetically sealed for the purpose of reduced maintenance and better quality. The power range is usually from 200 to 2000 kVA within 35 kV and the main use is the distribution of energy in cities and centres with different houses. The main advantage is the great extension of use in different outdoor applications [1].

### 2.1.3. Cast Resin Transformers

Such types of transformers with solid cast windings of epoxy D resin were developed in Europe, and this transformer design started to be broadly accepted in the United States in the 1980s. The cast resin transformers are typically three-phase and the power range varies usually from 250 to 4000 kVA within 35 kV. They are mostly used is in underground systems, mines and skyscrapers and the main benefits are the facts they are fireproof and explosion-proof, particularly when adapted for indoor applications [21]. Over installed 100,000 units have proven themselves in power distribution or converter operations all around the globe [22].

#### 2.1.4. Large Distribution Transformers

The main purpose of large distribution transformers is receiving energy delivered by higher voltage levels and to transform and distribute it to lower voltage substations or directly to large industrial consumers. Such transformers, which are three-phase and with copper or aluminium windings, are typically immersed in liquid oil as dielectric insulation and enclosed in a tank equipped with a cooling system and can be manufactured with on-load tap changer or off-circuit tap changer. Transformers built with on-load tap changer typically have a separate tap winding. Their power range usually varies from 2000 to 20000 kVA and the primary voltage is up to 72.5 kV and the main use is in industrial applications, grid interconnections, and special applications such as furnaces or railways [1,20].

#### 2.1.5. Medium Power Transformers

Medium power transformers are three phase or one phase transformers with a power range from 30 to 250 MVA and a voltage of over 72.5 kV and are used as network and generator step-up transformers, adapted for grid interconnections for small distance transmission lines up to 220 kV. Such transformers have tank-attached radiators or separate radiator banks. The main use is in interconnecting grids and the main advantages are their high tension and high power capacity [22].

#### 2.1.6. Large Power Transformers

The large power transformers are adapted for large distance grid interconnections and depending on the on-site requirements, they can be designed as multi-winding transformers or autotransformers, in 3-phase or 1-phase versions. The transmission lines are above 220 kV and the power range is typically above 250 MVA and up to and more than 1000 MVA and voltages are up to 1200 kV. Their main use is in interconnecting grids and main power stations and the main advantages are the high tension and high power. These transformers can also be step-down transformers which transform the voltage down from the transmission voltage level to a proper distribution voltage level. The power rating of such types of transformers may range up to the power rating of the transmission line [22].

### 2.2. Cooling Methods for Oil Immersed Transformers

The heat generated in transformer windings through resistive and other losses must be transferred into and taken out by the transformer oil. The winding copper maintains its mechanical strength up to a few hundred degrees Celsius. The transformer oil does not degrade considerably below around 140 °C however paper insulation deteriorates greatly if its temperature rises above about 90 °C [12]. The cooling oil flow must, consequently, guarantee that the insulation temperature is kept below this temperature inasmuch as possible. The study of the permitted temperature rises given in [12] demonstrated that a number of different values are permitted and that these depend on the method of oil circulation and thus different cooling modes are defined [1].

### 2.2.1. Oil Natural Air Natural (ONAN)

ONAN is the most common transformer cooling system where the natural convection of the oil is used for cooling. In such method the hot oil flows to the upper part of the transformer tank and the location left empty is occupied by cold oil. The hot oil which flowed to the upper side will dissipate heat in the atmosphere and will cool down and sink and as a consequence, the transformer oil in the tank will continuously circulate when the transformer is loaded. In order to increase the effective surface area in order to accelerate the heat transfer—extra dissipating surface in the form of tubes or radiators connected to the transformer tank is often installed, a part that is known as the transformer radiator or transformer radiator bank [23,24].

### 2.2.2. Oil Natural Air Forced (ONAF)

The heat dissipation can be increased through the expansion of the dissipating surface but when natural convection is not enough the transformer is cooled more rapidly by applying forced air flow on that dissipating surface. For this purpose fans that dissipate air on the cooling surface are employed; the forced air circulation removes the heat from the surface of radiator and provides improved cooling when compared to natural air. Since the heat dissipation rate is faster by employing the Oil Natural Air Forced (ONAF) method instead of ONAN, the transformer can tolerate extra loads without crossing the accepted temperature limits [3].

### 2.2.3. Oil Forced Air Forced (OFAF)

By employing an Oil Forced Air Forced (OFAF) cooling system the oil is forced to circulate within the closed loop of the transformer tank through the use of oil pumps. The main advantage is that it is a compact system and for the same cooling capacity of the former two systems of transformer cooling OFAF occupies considerably less space. Forcing the oil circulation and removing the air over the radiators will usually achieve a smaller, economical transformer than either ONAF or ONAN. However, the maintenance burden is increased due to the additional required oil pumps, motors and radiator fans. The application of such transformers in attended sites must have good maintenance procedures. OFAF cooling is used usually by both generator and power station interbus transformers [3,23].

### 2.2.4. Oil Forced Water Forced (OFWF)

Since the water is a better heat conductor than air, in the Oil Forced Water Forced (OFWF) cooling system of transformer, the hot oil is transferred to an oil-to-water heat exchanger by means of an oil pump where the oil is cooled when in contact with cold water on oil pipes of the heat exchanger [23,25].

### 2.2.5. Oil Directed Water Forced (ODAF)

Oil Directed Water Forced (ODAF) which is mainly utilised in very high rating transformers and is an improved version of OFAF where forced oil circulation is directed to flow through predetermined conduits in the transformer windings. The cooled oil enters the transformer tank from the radiator or

cooler and flows through the windings where predetermined oil flow paths crossing the insulated conductor are provided for ensuring a faster rate of heat transfer [3].

### 2.2.6. Oil Directed Water Forced (ODWF)

Oil Directed Water Forced (ODWF) is similar cooling method to ODAF and the only difference is that the hot oil temperature is decreased in the cooler through the use of forced water instead of air [3].

### 2.3. Transformer Thermal Diagrams

Since the power transformer it is an essential element of the distribution network, an appropriate preservation of mineral-oil-filled distribution transformers is very important in power systems, consequently a need is generated to adopt a protective approach regarding transformer loading, with the purpose of benefiting as much as possible from their availability and long term service [12].

The insulation system of a distribution transformer is fundamentally made of paper and oil which suffers from ageing. Any unexpected increase in the load results in a rise of the  $\theta_h$  and consequently affects the thermal decomposition of the paper [11,12,26–28].

Due to the fact the temperature distribution is not uniform, the hottest section of the transformer will subsequently be the most damaged. As a consequence,  $\theta_h$  directly affects the lifetime of transformers [29,30].

A basic thermal diagram is created in [12], as shown in Figure 1, on the understanding that such a diagram is the simplification of a far more complex distribution. The assumptions made in this simplification are as follows [12]:

- The oil temperature inside the tank suffers a linear increase from bottom to top, regardless of the cooling method.
- It is also estimated that the temperature rise of the conductor at any position up the winding is presumed to increase linearly, parallel to the oil temperature rise, with a constant difference  $g_r$  among the both straight lines, where  $g_r$  is considered to be the difference between the winding average temperature rise by resistance and the average oil temperature rise in the tank.
- The  $\theta_h$  rise is higher than the temperature rise of the conductor at the top of the winding, due to an allowance that has to be made for the increase in stray losses, for possible additional paper on the conductor and for differences in local oil flows. To take into consideration such non-linearities, the difference in temperature between the  $\theta_h$  and the top-oil ( $\theta_o$ ) in tank is made equal to  $H \times g_r$ , namely,  $\Delta\theta_{h,r} = H \times g_r$ .

The description of Figure 1 concerning the transformer sections is made as follows:  $A$  is the  $\theta_o$  temperature derived as the average of the tank outlet oil temperature and the tank oil pocket temperature,  $B$  is the mixed oil temperature in the tank at the top of the winding (often assumed to be the same temperature as  $A$ ),  $C$  is the temperature of the average oil in the tank,  $D$  is the oil temperature at the bottom of the winding and  $E$  is the bottom of the tank.

As for the variables,  $g_r$  is considered to be the average winding to average oil (in tank) temperature gradient at rated current,  $H$  the Hot-spot factor,  $P$  is the  $\theta_h$ ,  $Q$  is the average winding temperature determined by resistance measurement, while in the  $y$  axis are situated the relative positions and in

the  $x$  axis the temperature values. The symbol (●) means a measured point and (■) signifies a calculated point.

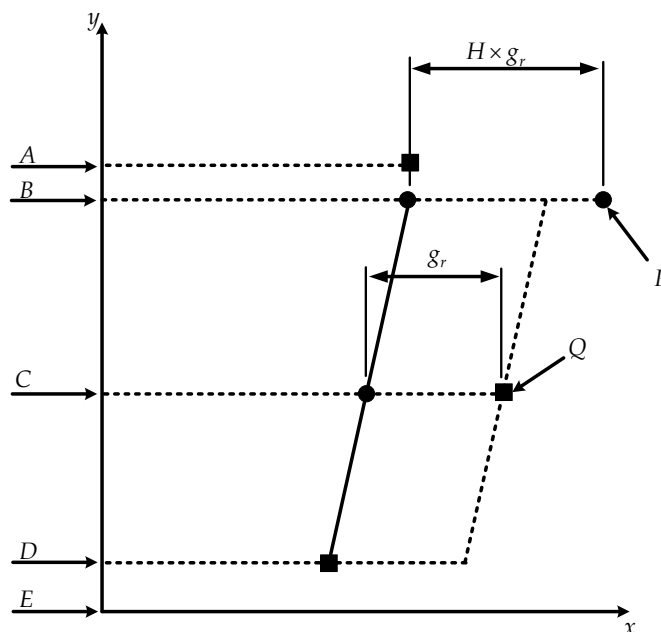

**Figure 1.** Thermal diagram.

As mentioned before, the  $\theta_h$  should be referred to the adjacent oil temperature as it is assumed to be the  $\theta_o$  inside the winding. However, measurements have shown that the  $\theta_o$  inside a winding might be, depending on the cooling method, up to 15 K higher than the mixed  $\theta_o$  inside the tank [12].

For many transformers in service, the  $\theta_o$  inside a winding is not accurately known. On the other hand, for most of these units, the  $\theta_o$  at the top of the tank is well identified, either by measurement or by calculation. The calculation rules in this part of IEC 60076 [12] are based on the following assumptions:

- $\Delta\theta_{o,r}$  the  $\theta_o$  rise in the tank above  $\theta_a$  at rated losses [K];
- $\Delta\theta_{h,r}$  the  $\theta_h$  rise above  $\theta_o$  in the tank at rated current ( $I_r$ ) [K].

The parameter  $\Delta\theta_{h,r}$  can be determined either by direct measurement during a heat-run test or by a calculation model validated by direct measurements.

In Figure 2 an alternative basic thermal diagram of oil transformers is represented, as proposed in [31], where a cross section of an oil transformer is shown.

In Figure 2,  $\Delta\theta_b$  is the bottom oil temperature rise in cooler and winding in K,  $\Delta\theta_r$  is the average winding temperature rise in winding in K,  $\Delta\theta_w$  is the top oil temperature rise in winding in K,  $\Delta\theta_c$  is top oil temperature rise in cooler and winding, K. For instance part of the winding at the bottom of the leg is in cool oil and part at the top of the leg will be encircled by the hottest oil. To measure these two values a thermometer has to be inserted in the oil at the top of the tank close to the outlet to the coolers and another at the bottom of the tank. The average oil temperature will be midway between both values and the average gradient of the windings is the difference between average oil temperature-rise and average winding temperature-rise, namely, the temperature-rise determined from the change of winding resistance [1].



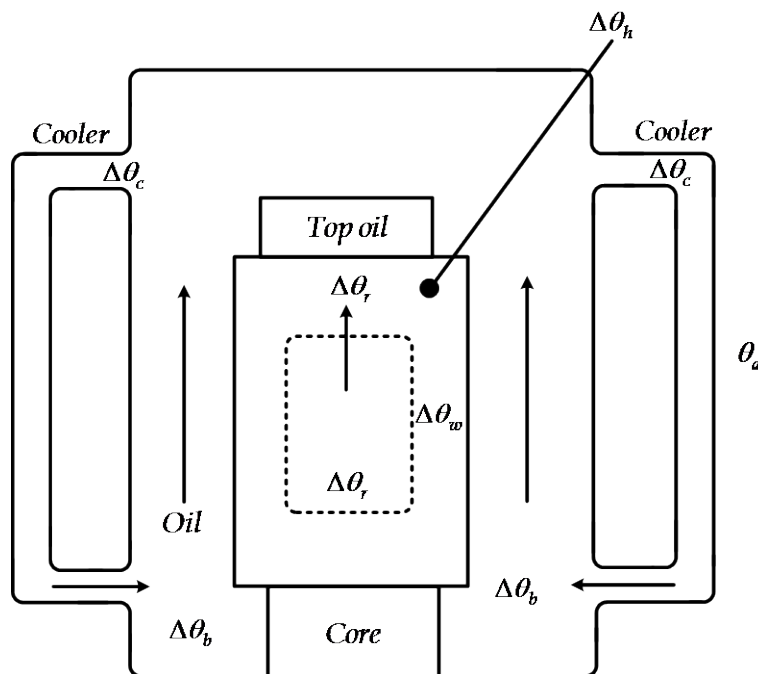

**Figure 2.** Basic thermal diagram of oil transformers.

The hot-spot factor is one of reasons why there will be such a difference between the maximum gradient and average gradient as can be seen in Figure 3, which represents an assembly of conductors surrounded by horizontal and vertical cooling ducts. The conductors at the corners are cooled directly on two faces, whilst the remaining ones are cooled on a single face only. In addition, except in the case of the oil flow being forced and directed, the heat transfer will be poorer on the horizontal surfaces, as a result of the poorer oil flow rate. Therefore, the oil in these regions could well be hotter than the general mass of oil in the vertical ducts [1].

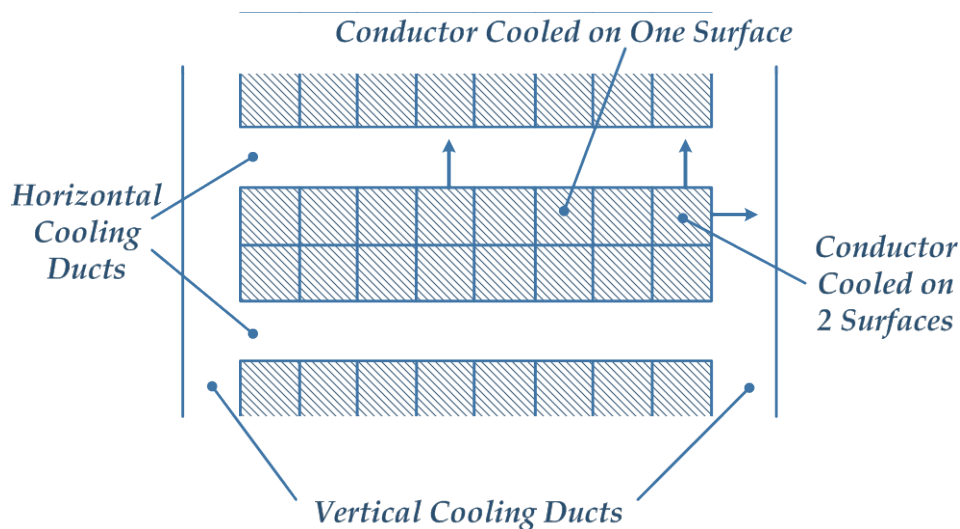

**Figure 3.** Winding hot spots.

## 2.4. Mathematical Formulation

### 2.4.1. Transformer Ageing Equations

The rate as a result of which the ageing of paper insulation for a  $\theta_h$  is increased or decreased when compared with the ageing rate at a reference  $\theta_h$  (110 °C) [12] is the relative ageing rate  $V$  [11].

The relative ageing rate meant for the thermally upgraded paper is above one for  $\theta_h$  greater than 110 °C and means that the insulation ages faster compared to the ageing rate at a reference  $\theta_h$ , and it is lower than one for  $\theta_h$  less than 110 °C [13].

For the thermally upgraded paper, which is chemically modified with the aim of improving the stability of the cellulose structure, the relative ageing rate  $V$  is expressed by Equation (1) for thermally upgraded paper and by Equation (2) for non-thermally upgraded paper [11]:

$$V = e^{\left(\frac{15000}{110+273} - \frac{15000}{\theta_h+273}\right)} \quad (1)$$

$$V = e^{\frac{(\theta_h-98)}{6}} \quad (2)$$

After a certain period of time, the loss of life  $L$  during the time interval  $t_n$  is as follows Equation (3):

$$L = \int_{t_1}^{t_2} V dt \quad \text{or} \quad L \approx \sum_{n=1}^N V_n \times t_n \quad (3)$$

According to [11] experimental evidence point out that the relation of insulation deterioration to time and temperature follows an adaptation of the Arrhenius reaction rate theory that displays the following form Equation (4):

$$\text{Per unit life} = A e^{\left(\frac{B}{\theta_h+273}\right)} \quad (4)$$

where  $A$  and  $B$  are constants.

The transformer per unit insulation life relates per unit transformer insulation life to winding hottest spot temperature and it is presented in Equation (5), which should be used for both distribution and power transformers since both are manufactured using the same cellulose conductor insulation. The use of this expression isolates temperature as the principal variable affecting thermal life. It also indicates the degree to which the rate of aging is accelerated beyond normal for temperature above a reference temperature of 110 °C and is reduced below normal for temperature below 110 °C. The equation is as follows Equation (5):

$$\text{Per unit life} = 9.80 \times 10^{-18} e^{\left(\frac{1500}{\theta_h+273}\right)} \quad (5)$$

The per unit transformer insulation life expression can be used in the following two ways. It is the basis for calculation of an aging acceleration factor (FAA) for a given load and temperature or for a varying load and temperature profile over a 24 h period. FAA has a value greater than 1 for winding  $\theta_h$  greater than the reference temperature 110 °C and less than 1 for temperatures below 110 °C. The equation for FAA is as follows Equation (6) [11]:

$$FAA = e^{\left(\frac{1500}{383} \frac{1500}{\theta_h + 273}\right)} \quad (6)$$

Equation (6) can therefore be used to calculate the equivalent aging of the transformer. The equivalent life (in hours or days) at the reference temperature that will be consumed in a particular time period for the given temperature cycle is the following Equation (7):

$$F_{EQA} = \frac{\sum_{n=1}^N F_{AA,n} \Delta t_n}{\sum_{n=1}^N \Delta t_n} \quad (7)$$

where  $F_{EQA}$  is the equivalent aging factor for the total time period and  $n$  is index of the time interval,  $t$  while  $N$  is total number of time intervals,  $F_{AA,n}$  is the aging acceleration factor for the temperature which exists during the time interval  $\Delta t_n$ .

The insulation per unit life equation can be used to calculate percent of total LOL as well, as has been the practice in earlier editions of the referenced transformer loading guides [11]. To do so, it is essential to arbitrarily determine the normal insulation life at the reference temperature in hours or years. Then the hours of life lost in the total time period is calculated by multiplying the equivalent aging determined in Equation (4) by the time period ( $t$ ) in hours. This gives equivalent hours of life at the reference temperature which is consumed in the time period and typically the total time period used is 24 h. The equation is given as follows Equation (8):

$$\% \text{ Loss of Life} = \frac{F_{EQA} \times t \times 100}{\text{Normal insulation life}} \quad (8)$$

#### 2.4.2. Temperature Rise Equations for Linear Loads

The simple idea of the  $\theta_o$  rise model is that an increase in the losses is a consequence of an increase in the loading of the transformer and subsequently of the overall temperature in the transformer. The temperature fluctuations are dependent on the global thermal time constant of the transformer which consequently depends on the rate of heat transfer to the environment and the thermal capacity of the transformer [27,28].

In steady state, the total transformer losses are proportional to the top-oil temperature rise ( $\Delta\theta_o$ ). As a result,  $\Delta\theta_o$  is mathematically presented as follows Equation (9):

$$\Delta\theta_o = \Delta\theta_{o,r} \times \left(\frac{P}{P_R}\right)^x = \Delta\theta_{o,r} \times \left[\frac{1 + R \times K^2}{1 + R}\right]^x \quad (9)$$

where,  $P$  is the total losses in W,  $P_R$  is the total losses at rated load in W,  $\Delta\theta_{o,r}$  is top-oil temperature rise at rated current in K,  $R$  is the ratio of load loss to no-load loss at rated load ( $K = 1$ ),  $K$  is the load in [per unit] or [%], and  $x$  is the oil exponent.

The hot-spot temperature rise over top-oil temperature ( $\Delta\theta_h$ ) is proportional to the transformer winding loss considering the winding exponent and the hot-spot temperature rise at rated loss. Thus, the  $\Delta\theta_h$  can be expressed as follows Equation (10):

$$\Delta\theta_h = \Delta\theta_{h,r} \times K^y \quad (10)$$

where the superscript  $y$  stands for the winding exponent. Therefore, in steady state, the  $\theta_h$  is calculated as follows Equation (11):

$$\theta_h = \theta_a + \Delta\theta_o + \Delta\theta_h \quad (11)$$

By inserting Equations (9) and (10) into Equation (11), the following equation represents the  $\theta_h$  in steady state Equation (12):

$$\theta_h = \theta_a + \Delta\theta_{o,r} \times \left[ \frac{1 + R \times K^2}{1 + R} \right]^x + \Delta\theta_{h,r} \times K^y \quad (12)$$

On the other hand, under transient conditions, the  $\theta_h$  is described as a function of time, for varying load current and ambient temperature [12]. The oil insulation of a transformer under working conditions is exposed to different types of stress, such as thermal, mechanical, environmental, and electrical. The outcome of each stress factors or the interaction effects of them affect the ageing of the insulating system [28].

In an occurrence of increasing steps of loads, the top-oil and winding hot-spot temperatures escalate to a level corresponding to a load factor  $K$ . The top-oil  $\theta_o(t)$  temperature is expressed by Equation (13) as follows:

$$\theta_o(t) = \Delta\theta_{o,i} + \left\{ \Delta\theta_{o,r} \times \left[ \frac{1 + R \times K^2}{1 + R} \right]^x - \Delta\theta_{o,i} \right\} \times \left( 1 - e^{-t/(k_{11} \times \tau_o)} \right) \quad (13)$$

where  $\Delta\theta_{o,i}$  represents the top-oil (in tank) temperature rise at start in K,  $\Delta\theta_{o,r}$  signifies the top-oil temperature rise at the rated current in K,  $R$  is the ratio of load loss to no-load loss at rated current,  $K$  is the load factor (load current/rated current),  $x$  is the oil exponent,  $k_{11}$  is a thermal model constant and  $\tau_o$  is average oil time constant.

The hot-spot temperature rise  $\Delta\theta_h(t)$  is described by Equation (14):

$$\Delta\theta_h(t) = \Delta\theta_{h,i} + \left\{ H \times g_r \times K^y - \Delta\theta_{h,i} \right\} \times \left[ k_{21} \times \left( 1 - e^{-t/(k_{22} \times \tau_w)} \right) - (k_{21} - 1) \times \left( 1 - e^{-t \times k_{22} / \tau_o} \right) \right] \quad (14)$$

where  $\Delta\theta_{h,i}$  represents the hot-spot-to-top-oil (in tank) gradient at start in K,  $H$  is the hot-spot factor,  $g_r$  is the average winding to average oil (in tank),  $y$  is the winding exponent, both  $k_{21}$  and  $k_{22}$  are thermal model constants and  $\tau_w$  symbolizes a winding time constant.

In case of decreasing step of loads, the  $\theta_o$  and winding hot-spot temperatures decrease to a level equal to a  $K$  [12]. The top-oil temperature  $\theta_o(t)$  can be calculated using Equation (15):

$$\theta_o(t) = \Delta\theta_{o,r} \times \left[ \frac{1 + R \times K^2}{1 + R} \right]^x + \left\{ \Delta\theta_{o,i} - \Delta\theta_{o,r} \times \left[ \frac{1 + R \times K^2}{1 + R} \right]^x \right\} \times \left( e^{-t/(k_{11} \times \tau_o)} \right) \quad (15)$$

The hot-spot temperature rise is given by Equation (16):

$$\Delta\theta_h(t) = H \times g_r \times K^y \quad (16)$$

Finally, with  $\theta_o(t)$  and  $\Delta\theta_h(t)$  from Equations (13) and (14) for increasing load steps, and Equations (15) and (16) for decreasing load steps and considering  $\theta_a$  the overall hot-spot temperature  $\theta_h(t)$  equation is calculated by Equation (17):

$$\theta_h(t) = \theta_a + \theta_o(t) + \Delta\theta_h(t) \tag{17}$$

### 2.4.3. Differential Equations Solution for Linear Loads

The following subsection describes the use of heat transfer differential equations, applicable for arbitrarily time-varying load factor  $K$  and time-varying  $\theta_a$ . The purpose of the heat transfer differential equations is to be the basis for software that could to process data in order to define  $\theta_h$  as a function of time and subsequently the corresponding insulation life consumption and LOL. The differential equations are represented in block diagram form in Figure 4 [12].

As it can be seen in Figure 4, the inputs are the load factor  $K$ , the ambient temperature  $\theta_a$  on the left and the output is the desired  $\theta_h$ , on the right. The Laplace variable  $s$  is in essence the derivative operator  $d/dt$ .

In Figure 3 [12], the second block in the upper most itinerary symbolizes the  $\theta_h$  rise dynamics. The first term (with numerator  $k_{21}$ ) represents the fundamental hot-spot temperature rise, previously to the effect of changing oil flow past the hot-spot to be taken into consideration. The second term (with numerator  $k_{21} - 1$ ) represents the varying rate of oil flow past the hot-spot, a phenomenon which changes in a slower mode. The combined effect of these two terms is to justify for the fact that a sudden rise in load current could cause an otherwise unexpectedly high peak in the hot-spot temperature rise, immediately after the sudden load change.

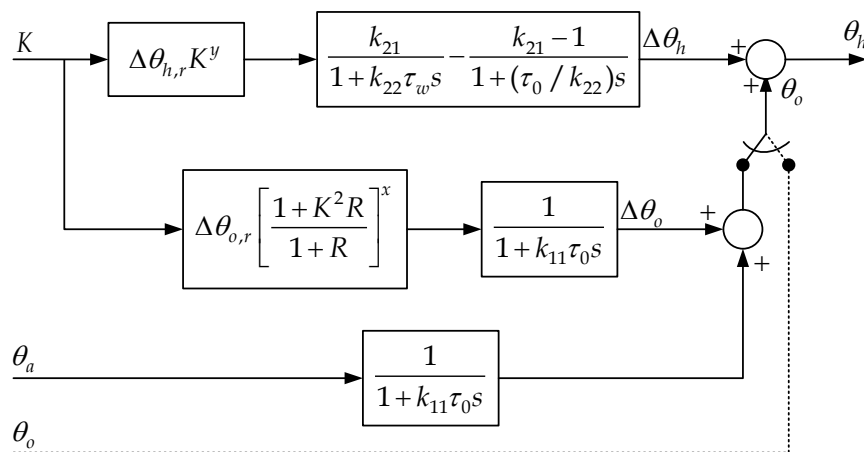

**Figure 4.** Block diagram representation of the heat transfer differential equations.

If the  $\theta_o$  can be measured as an electrical signal into a computing device, then an alternative formulation is the dashed line path, with the switch in its right position; the  $\theta_o$  calculation path (switch to the left) is not required. The time step will be less than one-half of the smallest time constant  $\tau_w$  to obtain a reasonable accuracy. Additionally,  $\tau_w$  and  $\tau_0$  must not be set to zero.

#### 2.4.4. Transformer Ageing Equations for Non-Linear Loads

In general, winding eddy losses, stray losses in other structural parts and, in general, potential regions of excessive heating can be inflated by the presence of harmonic currents. Ohmic losses divide into no load or core losses and load losses expressed as Equation (18):

$$P_T = P_{NL} + P_{LL} \quad (18)$$

where  $P_T$  is the global losses,  $P_{NL}$  is the no load losses and  $P_{LL}$  gathers the losses related to primary and secondary currents flowing through the windings ( $I^2R$ ) and stray losses that are classified into winding eddy losses and structural part stray losses. Winding eddy losses covers eddy current losses and circulating current losses between strands or parallel winding circuits. Therefore the total load loss is given by Equation (19):

$$P_{LL} = P + P_{EC} + P_{OSL} \quad (19)$$

where  $P$  is the losses due to load  $I^2R$ ,  $P_{EC}$  is the winding eddy losses and  $P_{OSL}$  is the other stray losses.

Other aspect to be take into account when estimating internal losses derived from harmonic load currents is the presence of a dc value in the load current which increase the magnetizing current and audible sound level without strongly penalizing the transformer core loss.

As a result, liquid-filled power transformer  $\theta_o$  rises as well as the total load losses with the increase of harmonic loading. Guidelines for power transformer derating considering the harmonic load impact on the top-oil rise due to the additional power losses can be found in [32]. The eddy-current loss  $P_{EC}$  generated by a harmonic load current is given by Equation (20):

$$P_{EC} = P_{EC-0} \times \sum_{h=1}^{h=h_{max}} \left( \frac{I_h}{I} \right)^2 h^2 \quad (20)$$

where  $P_{EC-0}$  is the winding eddy-current loss at the measured current and the power frequency,  $h$  is the harmonic order,  $h_{max}$  is the highest significant harmonic number,  $I_h$  is the root mean square (rms) current at harmonic of order  $h$  and  $I$  is the rms load current.

Load current rms calculation is obtained by Equation (21):

$$I = \sqrt{\sum_{h=1}^{h=h_{max}} I_h^2} \quad (21)$$

where  $h_{max}$  is the highest significant harmonic number.

In practical terms, transformer power supply capability can be described in terms of a proportional factor as a form of Equation (22):

$$F_{HL} = \frac{\sum_{h=1}^{h=h_{max}} \left[ \frac{I_h}{I} \right]^2 h^2}{\sum_{h=1}^{h=h_{max}} \left[ \frac{I_h}{I} \right]^2} \quad (22)$$

It defines an rms heating value as function of the harmonic load current. In other words it establish a ratio of the total winding eddy current losses due to the harmonics to the winding eddy current losses at the fundamental frequency.

A relationship similar to the harmonic loss factor for other stray losses that have to do with bus bar connections, structural parts, tank is expressed as Equation (23):

$$P_{OSL} = P_{OSL-R} \sum_{h=1}^{h=h_{max}} \left( \frac{I_h}{I_R} \right)^2 h^{0.8} \quad (23)$$

where  $P_{OSL-R}$  is the other stray loss under rated conditions and  $I_R$  is the rms fundamental current under rated frequency and rated load conditions.

A harmonic loss factor  $F_{HL-STR}$  normalized to the rms current and to rms fundamental current is Equation (24):

$$F_{HL-STR} = \frac{\sum_{h=1}^{h=h_{max}} \left[ \frac{I_h}{I} \right]^2 h^{0.8}}{\sum_{h=1}^{h=h_{max}} \left[ \frac{I_h}{I} \right]^2} \quad (24)$$

Based on the knowledge of internal power losses sources the top-oil rise is calculated as [11] Equation (25):

$$\Delta\theta_o = \Delta\theta_{o,r} \left( \frac{P_{LL} + P_{NL}}{P_{LL-R} + P_{NL}} \right)^{0.8} \quad (25)$$

where  $\Delta\theta_o$  is the top-oil-rise over ambient temperature ( $^{\circ}\text{C}$ ),  $\Delta\theta_{o,r}$  is the top-oil-rise over ambient temperature under rated conditions ( $^{\circ}\text{C}$ ),  $P_{LL}$  is the load loss,  $P_{LL-R}$  is the load loss under rated conditions and  $P_{NL}$  is the no load loss. In turn, the load loss  $P_{LL}$  is calculated by Equation (26):

$$P_{LL} = P + F_{HL} \times P_{EC} + F_{HL-STR} \times P_{OSL} \quad (26)$$

where  $F_{HL}$  is the harmonic loss factor for winding eddy currents and  $F_{HL-STR}$  is the harmonic loss factor for other stray losses.

Then, hottest spot conductor rise is estimated by Equation (27):

$$\Delta\theta_g = \Delta\theta_{g,r} \left( \frac{P_{LL}(pu)}{P_{LL-R}(pu)} \right)^{0.8} \quad (27)$$

where  $\Delta\theta_g$  is the hottest-spot conductor rise over top-oil temperature,  $\Delta\theta_{g,r}$  is the hottest-spot conductor rise over top-oil temperature under rated conditions,  $P_{LL}(pu)$  is the per-unit load loss and  $P_{LL-R}(pu)$  is the per-unit load loss under rated conditions.

## 2.5. Limitations of IEEE and IEC Standards

### 2.5.1. IEEE Standard

The traditional IEEE standard  $\theta_h$  calculation technique utilises a number of assumptions that are not correct, such as the variation of ambient temperature is assumed to have an instantaneous effect on oil temperature, the oil temperature in the cooling duct is assumed to be identical to the top oil temperature, the change in winding resistance with temperature is neglected, the change in oil viscosity with temperature is neglected and the effect of tap position is also neglected [33].

Furthermore, experimental work has shown that at the onset of an abrupt overload, oil inertia induces a quick increase of oil temperature in the winding cooling ducts that is not reflected by the  $\theta_o$  in the tank. Therefore alternate sets of equations are being developed which take into account the recent improvements and all the aforementioned factors [33].

Another important development is the withdrawal of the “Thermal Duplicate” guide for the transformer definition that was frequently utilised to provide default values for winding temperature rise at rated load [34]. This reference will no longer be available to provide support to the  $\theta_h$  rise assessed by the manufacturer which could reduce the credibility of transformer manufacturers in providing the abovementioned critical thermal parameter [33].

### 2.5.2. IEC Standard

A new edition of the loading guide has been published in 2005 [12]. It is now clearer that the hot-spot factor  $H$  that links the average winding to oil gradient to the hotspot to top oil gradient can vary over an extensive range depending on transformer design and size impedance. In the IEC standard the correct calculation of the critical temperature difference between winding hottest spot and top oil will also depend on a manufacturer’s capability to correctly model the oil flow within the winding ducts, the heat transfer characteristics of the various insulation thickness utilised throughout the winding, the distribution of losses along the winding, and the impact of local format restricting the oil flow [33].

The IEC standard also recognized that the dynamic response of the previous calculation technique was not suitable as a sudden increase in load current could cause an unpredicted high peak in the winding  $\theta_h$ . To address all type of load variations, a comprehensive set of differential equations is given. Such equations take into account the oil time constant, the winding thermal time constant and three new constants to characterize the oil flow [33].

## 3. Factors which Influence the Transformer Ageing

Several factors, according to the literature, have an impact on the insulating paper and oil ageing, such as the EVs, harmonics,  $\theta_a$ , DR, DG and experimental loads created explicitly to study the impact on the LOL of the transformer. In Table 1 a survey is made of the available literature regarding the loads and other key factors that influence the ageing of the transformer.



**Table 1.** Factors/Types of Load that influence the transformer loss-of-life (LOL).

Factor Affecting the Transformer	Description	References
EV/PHEV	Studies that have been carried out to evaluate if the transformer insulation temperature could or not withstand the widespread adoption of EVs.	[13,27–30,35–74]
DG/PV	The operation of DG units may lead to reductions in the time evolution of transformers' LOL rate.	[26,49,75–85]
DR	DR can be utilised during contingencies to mitigate the LOL.	[15,16,86]
$\theta_a$	The possibility that $\theta_a$ rise may impact distribution transformer life through dielectric degradation.	[87–92]
Experimental Load	Study of different loads that might impact the $\theta_h$ and LOL of the transformer. They are of experimental nature or recorded in a specific moment and place.	[8,9,31,90,93–124]
Harmonics	Studies focusing on the effect of harmonics on the transformer's LOL.	[48,51,79,83,125–130]

### 3.1. Demand Response

The concept of DR is related to the eminent alteration of the electricity consumption pattern by end user customers, as a reaction to incentives or price signals, for technical or economic reasons when called or scheduled by the network or market operator. DR has been in recent times largely and intensely explored in order to take full advantage of the power system's operation [131].

The integration of DR resources can be fully addressed if the available DG resources are also considered. DG and DR can thus be put together through the implementation of smart grids [131].

As stated previously, due to the load growth, upgrade of power transformers could eventually be required at substations. The usual method of reinforcement for a growing load is expensive, therefore, utilities tend to increase the utilisation of already installed transformers which results into highly utilised systems. DR, as a solution for load modification in the electricity network, can be utilised during contingencies to mitigate the LOL, while simultaneously the transformer utilisation efficiency can be improved and monetary savings can be achieved in terms of deferred reinforcements [15]. The impacts of DR and other features of smart grids have also been investigated on the aging of transformers in the literature [15,16,86].

Humayun *et al.*, presented a novel DR-based optimization model to limit load on healthy transformers during contingencies. The model selects combination of the best remedial actions among DR, load curtailment and transferring load to a neighbouring substation [15]. Humayun *et al.*, also proposed an optimization model that quantifies the improvement of transformer utilisation through DR based on transformer  $\theta_h$  and applied to typical Finnish residential primary and secondary distribution transformers [16]. Jargstorf *et al.*, calculated the effect of DR aging based on the load of a group of customers and then based on their load being optimized by DR, also in this paper devices are scheduled based on the transformer temperature [86]. In Table 2 a compilation of transformers on which the ageing is influenced by DR is provided.

**Table 2.** Transformers on which the ageing is influenced by DR.

Transformer Capacity kVA	Cooling	Implementation		Technique	References
		Simulation	Field Test		
20/40/60/80	ODAF	√	-	Mixed integer quadratic programming	[86]
1600/40,000	ONAN	√	-	Optimization	[16]
40,000	OFAF	√	-	Optimization	[15]

Several results point out that the transformers utilisation can be increased considerably by using DR, which can also mitigate the LOL. The magnitude of the use benefit depends on the DR capability of the load and the loading increase can provide monetary benefits by delaying the investments in new equipment [15].

### 3.2. Harmonics

Distorted current flow in power systems infrastructure originates two main effects. One of them is a supplementary power loss justified by a higher rms value of the load. Furthermore, the ac resistance of a cable is raised since the skin and proximity effects depend on current frequency. Therefore conductor ohmic losses have a tendency to grow with an increasing introduction of nonlinear loads. The second consequence effect has to do with harmonic voltage drop across the electrical elements.

As for power transformers the main consequence relates to additional losses and consequently an increase of transformer oil temperature. Furthermore, other possible adverse effects may be revealed as resonances between the transformer inductance and system capacitance and mechanical stress of winding and lamination. The harmonic voltages may also contribute to higher losses with core hysteresis and eddy current.

As a result of the emergent use of modern electronic devices, harmonic currents produced in distribution systems are recently starting to be a “power quality” problem in power systems. A power quality problem is defined as any problem discovered in current, voltage or frequency deviations that cause a failure or malfunction of a customer’s equipment. There are a vast range of power quality factors such as: voltage flicker, voltage sag, voltage unbalance, voltage regulation, interruptions, voltage swell and harmonics. An emergent power quality concern is revealed to be harmonics distortion which is created by the non-linearity of customer loads. Harmonics are known to be the currents or voltages with frequencies that are integer multiples of the fundamental power frequency. The non-linearity of the residential and industrial loads is quickly increasing as a consequence of the widespread applications of power electronics [125].

Solid state electronics are utilised to increase the energy efficiency of electrical load devices. The harmonic distortion of current is increasing with a higher utilisation of nonlinear loads *i.e.*, solid state devices. Examples of nonlinear loads are a television set, personal computer, laptop, laser printer, smartphone, compact fluorescent lamp, battery charger, fluorescent tube with electronic ballast, adjustable speed drives, continuous power supply and all the equipment powered by switched-mode power supply units. Such nonlinear loads draw more current than the fundamental current and generate overloading of the distribution system components [125].

The grid harmonics cause destructive impacts on distribution transformers. Increase in the transformer power losses and consequently the resultant temperature rises are the main concern of the impact of

harmonics. This could lead to an increase in its insulation  $\theta_h$  and thus, LOL [126]. Due to the initial costs of transformers, and the grid connectivity issues that may appear during their replacements, it is imperative to preserve the transformers and mitigate the lifetime reduction. As a result, researching the effect of current harmonics on the lifetime of distribution transformers is important for the grid design and maintenance [127].

Various studies have been made in literature, shown in Table 3, for modelling the effect of current harmonics on transformer load loss. Moses proposed a new aging calculation method for three-phase three-leg power transformers under (un)balanced and (non)sinusoidal operating conditions where the impacts of magnetic saturation, couplings, and hysteresis are accurately included [130]. Kazerooni and Kar studied the creation of an optimal load management of EV battery charging and optimization of harmonic impacts on the load loss,  $\theta_h$  and life time of distribution transformers [51]. Rad *et al.*, studied the effect of grid harmonics on eddy current loss, other stray losses,  $\theta_h$ , and LOL of six 100 kVA distribution transformers [127]. Soto *et al.*, addressed the impacts on distribution transformers due to increasing plug-in hybrid electric vehicles (PHEV) loads on the distribution infrastructure, while conducting PV harmonics compensation [48]. Taheri *et al.*, presented the determination of field distribution on the transformer components using finite element method and the calculations of  $\theta_h$  and  $\theta_o$  under harmonic conditions according to two techniques—dynamic thermal model and IEEE guide [129].

**Table 3.** Transformers on which the ageing is influenced by Harmonics.

Transformer Capacity kVA	Cooling	Implementation		Technique	References
		Simulation	Field Test		
1.65/7.5/60/2000	-	√	-	Proposed Model	[130]
10	ONAN	√	-	Impact analysis	[83]
100	-	-	√	Optimization	[51]
100	-	√	-	Impact analysis	[127]
100/500	-	-	√	Impact analysis	[125]
200	ONAF	√	-	Rapid-prototyping control	[48]
750	ONAN	-	√	Impact analysis	[79]
1500/2500	-	-	√	Impact analysis	[128]
31,500	ONAF	√	-	Impact analysis	[126]
250,000	ONAF	√	-	Finite element method	[129]

Transformers will begin to experience unprecedented loads from EV charging in the future and the battery chargers for EVs have high ratings and employ nonlinear switching devices which could result in significant harmonic voltage and currents injected into the distribution system. Fast charging, which is considered to be the preferable technique to attract end users and mitigate the EV average autonomy, implies precisely these types of nonlinear loads [51,132]. The standards applied to the low-power EV chargers are IEC 61000-3-2 and IEC 61000-3-4, which set limits to the harmonic emissions generated by the charger [132]. The European standard for public power supply is EN 50160 which states that all loads that are connected to the power network have to provide such a low effect on the network that it does not origin a violation of the power supply conditions stated in this standard. This signifies also that the EV chargers, once connected to a public network, must not influence the network operation to a degree in which can cause deviation from the standard [132].

### 3.3. Distributed Generation

Electric power systems could turn out to be more heavily loaded in the next decades due to the increasing demand for electricity. The option of utilising DG is a greater challenge for many utilities due to the reason that economic and environmental concerns limit the construction of new transmission infrastructure and large-sized generation units [133]. Furthermore, since DG units are auxiliary modular resources, the output of a DG unit could change over time, especially the output power of several DGs such as photovoltaic systems (PV) and wind turbines which are heavily dependent on the weather, since it cannot be anticipated accurately. Consequently, the uncertainty of DG output needs to be included in the system analysis [134]. The European Union targets demonstrate noticeably the importance of DG, specifically the fact that the share of renewable DG is expected to be 20% of gross energy consumption at the end of 2020 and 50% of gross energy consumption in 2050 [135,136].

When devoid of the use of an optimization process or power flow analysis outcomes, in radial systems the DG units are usually connected to the nodes at the end of the feeders or to the nodes with the highest load on the distribution side. Yet, it is worth noticing that the impacts of DG are strongly dependant on the power network structure and on the output power uncertainties when connecting to renewable DG resources [135]. According to the definition, the size of DG units can vary from several kW to quite a few MW and, in the area of customer locations, can be connected in sub-transmission or even transmission systems. This leads to the transmission and distribution networks being less charged. In the near future, optimal planning of the location and sizing of DG units will become more and more important for energy suppliers, grid operators and customers in terms of economic and technical aspects [137]. Currently many studies in the literature exist regarding this topic however most of them consider an ideal location of a single-DG unit or the size and location issues in separate due to the fact that the output power of renewable DG units is highly non-dispatchable. Also, the high penetration of DG elevates the level of system uncertainty and the fluctuation of the DG output power is achieved by using different strategies [135]. By not taking suitable measures for allocating and sizing DG units this concept could lose the functionalities required for an efficient system and eventually cause undesirable increases in power losses and electricity costs. Furthermore, at high penetration levels in the existing infrastructure and depending on the network structure and positions of the DG units, the contributing role of DG could reduce the and system reliability and efficiency [137].

The impacts of DG and more specifically PV on the aging of transformers have also been investigated in the literature [76–86]. The incorporation of rooftop PVs in residential networks at moderate penetration levels is starting to be a reality in many countries. Regardless of the technical challenges in the proper installation of PV units, one of the main benefits is the capacity of PV units to prolong the useful life time of distribution transformers [26,138].

Agah and Abyaneh presented a novel approach to quantify the economic benefits and the life extension made by the customer-owned DG units of actual distribution transformers installed in five sample cities in Iran [78]. In a [81] novel methodology is presented by Hamzeh *et al.*, in order to evaluate the micro-grids' reliability concerning the dynamic thermal aging failure of transformers. Masoum *et al.*, carried out an analysis into the impacts of rooftop PVs at different penetration levels on the performance of distribution transformers and residential networks [80]. In [79] Martin *et al.*, presented the findings of an analysis of the impact of the new rooftop PV installation at the University of Queensland,

in Brisbane (Australia), on the load profile of three transformers, with IEC thermal models applied to estimate  $\theta_h$ . Pezeshki *et al.*, studied the impacts of rooftop PVs at different penetration levels on the performance of distribution transformers and residential networks [26,75]. Awadallah *et al.*, presented a two-step study on the effects of harmonic distortion of solar panels on distribution transformers via simulation and experiments [83]. Jimenez *et al.*, showed the results obtained after monitoring a distribution transformer during an 18 months period and which attained unusually low power factor levels and where the operating temperature was used as an indicator of the stress on the transformer [84].

In Table 4 a compilation of transformers in which the ageing is influenced by DG and in some cases, just the PV, is given.

**Table 4.** Transformers on which the ageing is influenced by DG/PV.

Transformer Capacity kVA	Type	Cooling	Implementation		Technique	References
			Simulation	Experiment		
2	PV	-	√	-	Power quality impact	[76]
10	DG/Harmonics	ONAN	√	-	Impact analysis	[83]
75	PV	-	-	√	Test and analysis	[84]
100	PV	-	√	-	Impact analysis	[80]
200	PV/EV	ONAN	√	-	Impact analysis	[49]
200	PV	ONAN	√	-	Impact analysis	[26,75]
200	PV/EV Harmonics	ONAF	√	-	Rapid-prototyping control	[48]
315	DG	ONAN	√	-	Economic Benefit	[78,82]
750	PV	ONAN	-	√	Impact analysis	[79]
65,000	PV	ONAN	√	-	Sizing tool	[77]
1600/40,000	DG	-	√	-	Impact analysis	[85]
750,000	DG	-	√	-	Sensitivity analysis	[81]

As stated above, one of the areas where DG units can create significant economic benefits is through the life extension of distribution transformer. It is clear that any life extension is economically beneficial to the distribution network operator, which is usually the entity responsible for replacing deteriorated equipment in the distribution network [78]. Concerning DG technologies, it should be noted that wind turbines and microturbines appear as the most promising technologies from the perspective of distribution utility by being capable to generate millions of dollars in benefits for the entire installed distribution transformer population.

### 3.4. Ambient Temperature

The impact caused on the power distribution infrastructure through the analysis of the possibility that  $\theta_a$  rise may affect the distribution transformer life through dielectric degradation has been studied by several authors. The  $\theta_a$  is one of the most limiting factors that can impact the transformer insulation life. Since increasing the  $\theta_a$ ,  $\theta_h$  also increases and subsequently, causes the insulation life to decrease [87]. In Figure 5 the permissible kVA loading by varying  $\theta_a$  for natural cooled transformers for normal life expectancy is shown. This data does not apply for ambient temperature below 0 °C or above 50 °C and is based on [7].

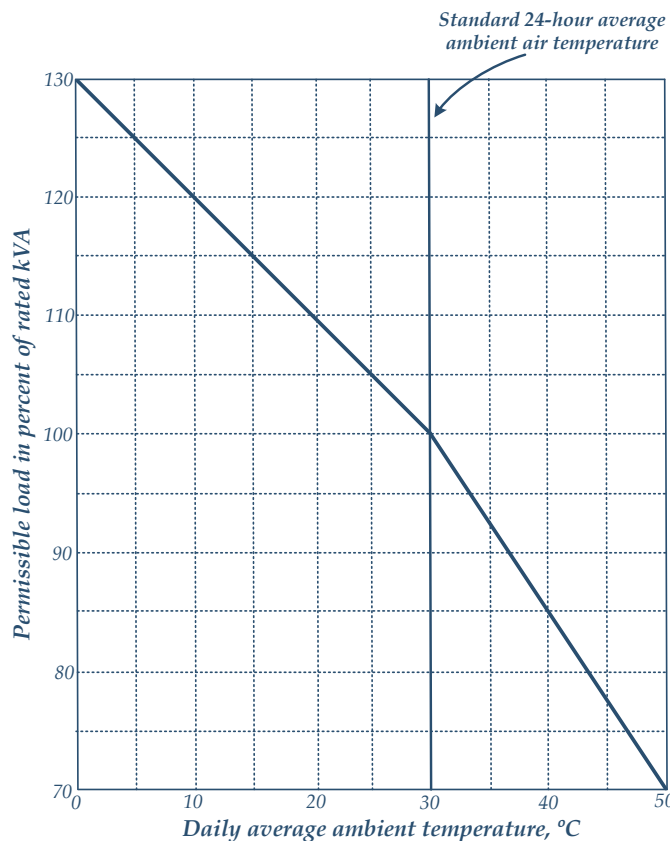

**Figure 5.** Permissible kVA loading by varying  $\theta_a$  for natural cooled transformers.

Several authors have studied the impact of the  $\theta_a$  on the LOL of transformers. Stahlhut *et al.*, illustrated the possible effects of increased  $\theta_a$  due to various causes, including climate change and urbanization, on power distribution transformers in service at five locations in the U.S. [91]. Sathyanarayana *et al.*, studied the distribution transformer life assessment with  $\theta_a$  rise projections by using the Monte Carlo method [92]. Shiri *et al.*, investigated a new thermal model for the estimation of  $\theta_h$  in transformers that has been proposed and using this thermal model, the effect of the  $\theta_a$  on  $\theta_h$  and transformer insulation life is also studied [87]. Agah and Abyaneh presented a method for transformer LOL inference by integrating stochastic dependence between non-normal transformer load and  $\theta_a$  into analysis [90]. Ravetta *et al.*, showed the results of a study performed to individuate some appropriate thermal models to supervise the performance of oil-immersed distribution transformers installed in the basement of residential buildings, during summertime when temporary severe overload conditions occur [88]. In Table 5 a compilation of transformers on which the ageing is influenced by  $\theta_a$  is provided.

**Table 5.** Transformers on which the ageing is influenced by  $\theta_a$ .

Transformer Capacity kVA	Cooling	Implementation		Technique	References
		Simulation	Field Test		
25/50/75/100/167	ODAF ODWF	√	-	Monte Carlo	[92]
200	ONAN	-	√	Comparison	[90]
250/400/630	ONAN	-	√	Thermal model	[88]
2000	AN	√	-	Thermal model	[89]
180,000	OFAF	-	√	Thermal model	[87]

A study has shown that if two similar transformers are installed in two regions with different climates their average temperatures difference would be 11.1 °C, the insulation life of the transformer that is installed in the warmer region will be 2.53 times less than the life of the transformer working with lower  $\theta_a$ . Regarding the results of several studies, the distribution operator should be cautious when installing and using transformers with similar designs in various regions with different climates [87].

### 3.5. Experimental Load

Several studies are made focusing on different loads that might impact the  $\theta_h$  and LOL of the transformer. They are experimental or recorded data in a specific case and are usually conventional or artificial loads created with the purpose to increase the load in order to witness the effect they might have on the transformer  $\theta_h$ . Galdi *et al.*, presented a radial basis function network to predict the maximum winding  $\theta_h$  of a power transformer in the presence of overload conditions [124]. Lachman *et al.*, used a comprehensive approach to dynamic loading of power transformers with nine transformer-months of real-time field data [95]. Jauregui-Rivera *et al.*, developed a methodology for assessing the reliability of thermal-model parameters for transformers estimated from measured data [122]. Weekes *et al.*, calculated the level of risk and management of heavily loaded converter transformers for future operation which can be assessed by examining the average rate of LOL of the insulation [107]. Elmoudi *et al.*, examined a transformer thermal dynamic model for use in an on-line monitoring and diagnostic system [104]. Koufakis *et al.*, studied the measurements of insulating resistance in distribution transformers, at several temperatures, and thereafter proceed to the calculations of the thermal coefficient of the transformers [117]. In Table 6 is possible to observe a compilation of several studies that were made focusing on different loads that could impact the  $\theta_h$ .

### 3.6. Electric Vehicles

If widely adopted, EVs hold the promise of radically reducing carbon emissions derived from the transport section and could, consequently, form a major thrust in the global efforts to meet the reduction of emission targets [139,140]. The use of EVs is more challenging than PHEVs since the first are powered only by electricity.

Even though the EVs would be primarily utilised for transportation, they could be virtually viewed as a distributed storage resource from the point of view of a System Operator. Accordingly, when EVs are not used to satisfy their intended role, they could provide a variety of ancillary services to the power system such as operating reserves, regulation, back-up power *etc.* Such use of EVs might also support peak shifting [39].

**Table 6.** Transformers on which the ageing is influenced by unspecified experimental loads.

Transformer Capacity kVA	Cooling	Implementation		Technique	References
		Simulation	Field Test		
25	ONAN	√	-	Fuzzy logic	[116]
25	ONAN	√	√	Neural networks	[124]
25/37.5/50/100	-	-	√	Comparison	[102]
50	ONAN	√	-	Calculation of aging	[31]
50/100/250	-	-	√	Life cycle prediction	[117]
63	ONAF	-	√	Cost-benefit	[109]
100	-	-	√	Levenberg-Marquardt	[103]
105	ONAF	√	-	Uncertainty analysis	[112]
200	ONAN	-	√	Comparison	[90]
300	ONAN/F	√	-	Risk assessment	[107]
400	ONAN	-	√	Test and analysis	[114]
500	-	-	√	Least squares	[108]
630	ONAN	-	√	Proposed model	[100]
2500	ONAN	-	√	Non-linear least square	[93]
2500	ONAN	-	√	Test program	[120]
8 000	-	√	-	Monte Carlo	[110]
27,000/36,000	ONAN	-	√	Comparison	[95]
45,000/500,000	OFAF	-	√	Non-linear least squares	[104]
40,000	OFAF/F	-	√	Statistical bootstrapping	[122]
167,000	OFAF	-	√	Electromagnetic analysis	[106]
250,000	ONAF	-	√	Proposed model	[119]
250 000	ONAF	√	-	Model assessment	[123]
250,000/273,000	ODAF	-	√	Proposed model	[8]
250,000/400,000	ONAN/F	-	√	Proposed model	[98]
605,000	OFAF	-	√	Accurate calculations Comparison	[96]
250,000/400,000	ONAN/F	-	√	Comparison	[121]
605,000/650,000	OFAF	-	√	Impact analysis	[101]
300,000	ODAF	-	√	Risk assessment	[9]
400,000	OFAF	√	-	Arrhenius-Weibull	[97]
1,000,000	-	√	-		

By facing an increasing number of EVs connected to power systems for charging, a real concern appears due to the fact that the existing distribution networks might turn out to be more heavily loaded than the expectation when they were designed. Low penetration levels of EVs could result in a low impact but, as the number of EVs rises, there could be a real possibility of local distribution networks becoming more congested [28].

An event of simultaneous charging of a large number of EVs can lead to grid inadequacy as regards to available security and capacity. Such occurrences could be avoided, if the EVs are properly integrated within the grid. Incorporating the EV within the grid is a significant opportunity, if they are going to be controlled properly [141]. Without the aforementioned integration, the grid could experience voltage sag, feeder congestions, line overloads, *etc.*



Distribution networks are intended to supply electricity to the final customers and their sizing is typically based on an estimated electricity demand. Consequently, there is a general need to develop modelling techniques in order to support the quantification of the effects on distribution networks in case of high penetration level of EVs charging loads and thus ensure that this environmentally nonthreatening technology is not needlessly constrained. The transformers are vital links in the power and distribution networks and which are to experience unprecedented loads from EV charging [27,28].

The constant and everyday charging during daytime will add extra loads to the distribution system resulting in increases of the power consumption. Since battery chargers are made of solid state electronic devices they produce harmonic currents which also impact and decrease the lifetime of the transformer [48,51].

Numerous studies have been carried out to assess whether the existing electricity network and essentially the transformer insulation temperature could withstand the widespread adoption of EVs [36–75]. Weckx *et al.*, presented a market-based multi-agent control mechanism that incorporates distribution transformer and voltage constraints for the charging of a fleet of EVs [50]. Qian *et al.*, developed a methodology to determine the impacts of high penetration level of EVs charging loads on the thermal ageing of power distribution transformers [29]. Hilshey *et al.*, described a method for estimating the impact of EVs charging on overhead distribution transformers, based on detailed travel demand data and under several different schemes for mitigating overloads by shifting EV charging times [13]. Razeghi *et al.*, studied the impacts of PHEVs on a residential transformer using stochastic and empirical analysis, where the electricity demand of a neighbourhood is modelled based on measured vehicle and household data [63]. Vicini *et al.*, discussed how increased deployment of EVs acts as a catalyst for development of transformer and home energy management systems in order to reduce the impact of EV battery charging on distribution transformers [41]. Turker *et al.*, proposed a rule-based charging algorithm of EVs and evaluate the consequences and impacts on the aging rate of low-voltage transformers [46]. In Table 7 a compilation of information of transformers on which the ageing is influenced by PHEVs, EVs, or both is presented. The current global status of EV market share can be considered low, not exceeding 7% in leading countries such as Norway [29]. Nevertheless, the authors believe that the impact of the penetration of EVs charging loads on thermal ageing of a distribution transformer is going to grow. Additionally, governmental incentive initiatives usually tend to target the penetration of new technologies [142], tax reduction schemes or potential subsidiary programs to promote the purchase and use of EVs are very likely to massively motivate users to replace their conventional car with an EV.

**Table 7.** Transformer types and info concerning EV penetration.

Transformer Capacity kVA	Type	Cooling	Implementation		Technique	References
			Simulation	Experiment		
25	EV	-	√	-	Genetic program	[36]
25	EV	-	√	-	Monte Carlo	[13]
25	EV/PHEV	-	√	-	Monte Carlo Impact analysis	[39,54,55,69]
25	EV/PHEV	-	√	-	Java-based	[40]
25	EV	-	√	-	Binomial probability	[42,43]
25	EV	-	-	√	Control strategies	[44,68]
25	PHEV	-	√	-	Impact analysis	[67]
25	EV/PHEV	-	√	-	ARMA	[70]
25	EV	-	√	-	Optimization	[72]
25/37.5	PHEV	-	√	-	Monte Carlo	[73]
37.5	EV/PHEV	-	√	-	Circuit model	[74]
37.5/50	EV/PHEV	-	√	-	Monte Carlo	[63]
50	EV/PHEV	ONAN	√	-	Impact analysis	[41]
50	EV	-	√	-	Probabilistic model	[71]
100	EV	-	-	√	Optimization	[51,52]
100	EV	-	√	-	Smart charging Impact analysis	[57,58,60,62]
160	EV	-	√	-	Rule-based algorithm	[46]
160	PHEV	ONAN	√	-	Impact analysis	[30,45]
200	PV/EV Harmonics	ONAF	√	-	Rapid-prototyping control	[48]
200	EV/PV	ONAN	√	-	Impact analysis	[49]
250	EV	-	√	-	Market based multiagent control	[50]
250	EV	ONAN	√	-	Impact analysis	[28]
250/300/500/750	EV	ONAN	√	-	EV scheduling	[35]
300	EV	-	√	-	Circuit model	[56]
315	PHEV	ONAN	√	-	Impact analysis	[64]
350	EV	-	√	-	Impact analysis	[59]
630	EV	ONAN	√	-	Impact analysis	[27]
1000/1500	EV	-	√	-	Smart charging	[37]
15,000	EV	-	√	-	Smart charging	[29]
36,000	PHEV	-	√	-	Impact analysis	[47]

#### 4. Aspects of Protection and Monitoring Systems

Transformers are one of the more expensive elements of equipment found in a utility's inventory. The globalisation and the energetic business dynamics unceasingly pressure utilities to do more with less. This leads to an increasing need for tools to support not only transformer protection but the intelligent monitoring of their status, activities and history—A challenge that could be taken by smart relays. Occasionally overcurrent relays are intended to provide fault protection and also be responsible for some level of overload protection. In many cases, the overload occurrence of transformer operation is performed by Control Centre load dispatchers since this function is too complex for most simple overcurrent relays to successfully handle [124,143].

In order to keep a reliable protection, it is required to monitor the temperatures. Supplementary prolongation of maximal load after a certain amount induces the ageing as a critical limit. The current thermal digital relays can perform the ageing calculation [143].

Usually, in many practical cases it is not expected that the shape of diagrams would change too much. Particularly it is not expected on small transformer units with fixed consumers. However, it seems too uncertain to protect a transformer only with a simple contact thermometer for  $\theta_o$  measurement and overcurrent protection set-up to a high p.u. current value. According to the experienced staff in power utility companies nobody would accept an extremely risky transformer loading without possessing useful information about the  $\theta_h$  and the ageing [143,144].

A monitoring system basically gives just additional security, but not fundamentally new content. First of all, an advantage is the possibility for the on-line decisions in circumstances of network faults. For instance, in every moment the monitoring system can provide in a clear form an overloading possibility of the transformer. A persistent problem in both monitoring systems thermal and digital relays is how to calculate the  $\theta_h$  caused by the complex heat transfer occurrences inside a transformer.

When a fault happens in a transformer, the damage is proportional to the fault time period. Consequently, the transformer has to be disconnected as fast as possible from the network. Quick reliable protective relays are thus utilised for detection of faults. Monitors can similarly detect faults and they can sense irregular conditions which may possibly develop into a fault [145].

The proportions of the transformer and the voltage level does influence on the extent and choice of protective equipment. Monitors avoid faults and protective relays limit the damage in the event of a fault. The cost for the protecting equipment is low when compared to the total cost and the cost involved in case of a transformer fault [146].

There are frequently different opinions about the range of transformer protection. In general, it is more or less standard that transformers with an oil conservator are provided with the following equipment [145]:

Transformers of less than 5 MVA:

- Gas detector relay (Buchholz relay);
- Ground fault protection;
- Overcurrent protection;
- Overload protection.

Transformers of more than 5 MVA:

- Gas detector relay (Buchholz relay);
- Ground fault protection;
- Oil level monitor;
- Overcurrent protection;
- Differential protection;
- Pressure relay for tap-changer compartment;
- Overload protection (thermal relays or temperature monitoring systems).

Power transformer protection relays in a power system are required to be able to differentiate internal faults from the remaining operating conditions, and current differential relays have been commonly used

for transformer protection. The relays, though, remain susceptible to malfunctioning over-excitation conditions or during magnetic inrush due to the magnetizing current becoming significant [147].

#### 4.1. Smart Relay

By using the transformer standard [12] IEC 60076–7 which presents the terms that define the transformer  $\theta_h$  calculation and with information from the  $\theta_o$ ,  $\theta_a$ , current and voltage transducers inputs, a smart transformer relay is proposed Fedirchuk and Rebizant in [143]. This relay is able to provide distinctive asset management functionality. This functionality comprises overload tracking with the temperature (adaptive overload), predictive overload early warning and automated load shedding based on temperature and/or current levels. Combined with the LOL estimation, the smart transformer relay delivers protection, monitoring and control for the transformer in one integrated solution. The basis of the smart transformer relay is the capacity to model the transformer behaviour by a satisfactory process [143]. Such kind of smart transformer relays allows a wide range of unique protection, monitoring and control devices in one integrated platform as proposed by the authors in Figure 6.

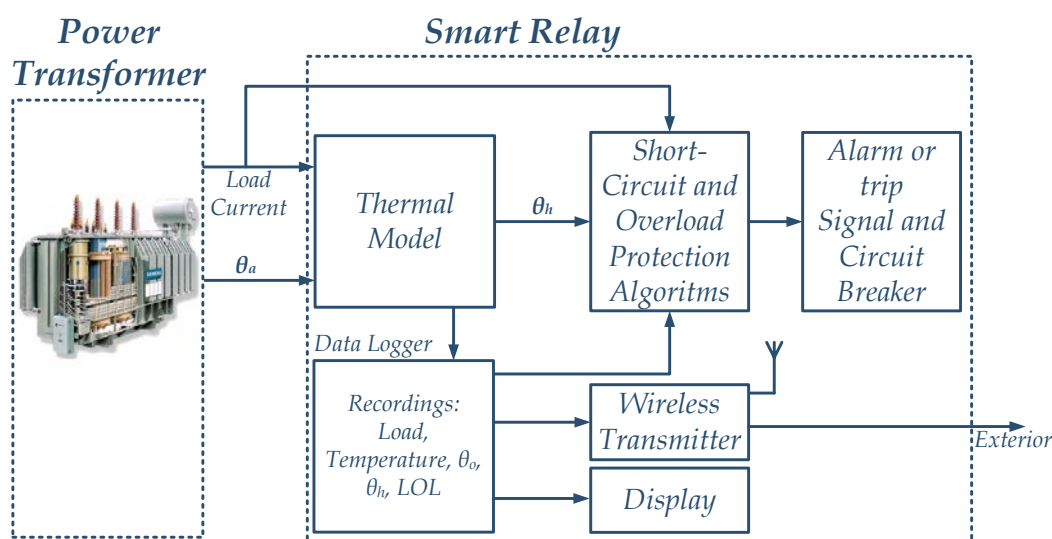

**Figure 6.** The proposed smart transformer relay.

However, another and an enhanced application of the IEEE transformer loading standard with a smart relay developed in [143] by the same authors, is the capacity to monitor both the transformer's current and/or temperature and establish multiple prioritized overload levels for alarm or trip. Such solution allows for the utility to have the ability to offer preferential service to customers and avoid unnecessary full-load transformer trips. Furthermore, the tap changer can be blocked if the current is above a pre-defined setting and prevent load restoration if  $\theta_h$  is greater than a pre-defined level.

#### 4.2. Transformer Condition On-Line Monitoring

It is widely recognized that the risks associated with overloading can be considerably reduced if the transformer conditions are closely monitored during the overload period [148,149]. The monitoring of winding  $\theta_h$  and dissolved gas-in-oil and furan-in-oil offers a major support to the operator when the transformer experiences overload conditions [33].

#### 4.2.1. Monitoring of Winding Temperature

The condition of transformer windings can be assessed by monitoring their equivalent circuit parameters. Modifications in the insulation temperature affect the winding temperature and can be monitored by observing the winding resistance values. Likewise, changes in the short circuit reactance can also provide information on the condition and structure of windings. The equivalent circuit parameters are not influenced by external faults and change only in the presence of an internal factors. Quick and reliable protection could be implemented by monitoring such parameters since inrush current and over-excitation does not affect them. The on-line monitoring of winding temperature can grant a dynamic evaluation of insulation degradation and the respective loss of life can then be transformed into cost. The cost attributed to loss of life has to be subtracted from the apparent benefits achieved from transmitting such extra load [150,151].

#### 4.2.2. DGA (Dissolved Gas Analysis)

Dissolved gas analysis is a test utilised as a diagnostic and maintenance tool for oil-filled apparatus. In normal conditions, the dielectric fluid existing in a transformer will not decompose at a fast rate. Nevertheless, thermal and electrical faults can accelerate the decomposition of the dielectric fluid, as well as the solid insulation. Resultant gases by this process are all of low molecular weight and include hydrogen, methane, ethane, acetylene, carbon monoxide, and carbon dioxide, and these gases will dissolve in the dielectric fluid. Anomalous conditions within a transformer can be detected prematurely by analysing the gases that accumulate within it. Analysing the specific proportions of each gas is helpful in identifying faults. Detailed information of such fault types originated from a variety of gases is present in Table 8 [151]. Faults detected in this manner may include processes such as sparking, corona, overheating, and arcing. If the right preventive measures are taken early in the detection of these gases, damage to equipment can be mitigated [152,153].

**Table 8.** Fault types indicated by a variety of gases.

Indication/Fault Gas	CO	CO <sub>2</sub>	CH <sub>4</sub>	C <sub>2</sub> H <sub>2</sub>	C <sub>2</sub> H <sub>4</sub>	C <sub>2</sub> H <sub>6</sub>	O <sub>2</sub>	H <sub>2</sub>	H <sub>2</sub> O
Cellulose aging	√	√	-	-	-	-	-	-	√
Mineral oil decomposition	-	-	√	√	√	√	-	√	-
Leaks in oil expansion systems, gaskets, welds, <i>etc.</i>	-	√	-	-	-	-	√	-	√
Thermal faults—Cellulose	√	√	√	-	-	-	√	√	-
Thermal faults in Oil 150–300 °C	-	-	√	-	Trace	√	-	√	-
Thermal faults in Oil 300–700 °C	-	-	√	Trace	√	√	-	√	-
Thermal faults in Oil >700 °C	-	-	√	√	√	-	-	√	-
Partial Discharge	-	-	√	Trace	-	-	-	√	-
Arcing	-	-	√	√	√	-	-	√	-

Numerous methods exist for the interpretation of laboratory results, for instance as those recommended in IEC Standard 60599 [154] and IEEE Standard C57.104–1991 [155]. Graphical and computational methods using gas ratios and proportions have been formulated for recognizing the characteristic patterns of dissolved gases associated with the main fault types. Such diagnosis procedures have been developed and validated using large data sets for equipment in service, where faults were identified and documented by maintenance experts monitoring the equipment [156].

The present environment of higher loading on aging transformers, increased service reliability requirements and postponed capital expenditures on new equipment have led the industry to investigate the employment of innovative transformer condition assessment and management tools. As transformers age, they suffer various stresses that can contribute to a multiplicity of failure mechanisms. Proper online DGA monitoring and diagnostic tools could help utilities to avoid unplanned failures, extend transformer useful life and lower maintenance costs [157].

As seen in Table 8, all fault types are indicated by a variety of gases and not just one. Consequently, diagnostic approaches that focus on multiple gases take into account the total gassing picture and provide the best diagnostic accuracy [151].

The majority of the DGA diagnostic tools utilised today can be found in the IEEE C57.104 or IEC 60599 guides, as well as other national or international guides based on them. As indicated in IEC 60599 and 60567 [154], there is constantly some degree of inaccuracy in laboratory dissolved-gas measurements, especially when concerning low gas concentrations. This inaccuracy influence gas ratios and other diagnostic calculations. Consequently, the results based on them might be correspondingly uncertain in a certain number cases [156].

## 5. Conclusions

In this paper a comprehensive review was made by analysing and discussing the existing studies in the literature on the effect of loads and other key factors on oil-transformer ageing. The state-of-the-art was extensively reviewed, each factor was analysed in detail, and useful comparative tables were created. Then, a smart transformer protection was researched in order to address the upcoming challenges. Finally, a monitoring system was considered essential to ensure reliability and sustainability of the transformer. An example is the transformer condition on-line monitoring, either by monitoring the winding temperature or through dissolved gas analysis.

## Acknowledgments

This work was supported by FEDER funds (European Union) through COMPETE and by Portuguese funds through FCT, under Projects FCOMP-01-0124-FEDER-020282 (PTDC/EEA-EEL/118519/2010) and UID/CEC/50021/2013. Also, the research leading to these results has received funding from the EU Seventh Framework Programme FP7/2007-2013 under grant agreement No. 309048.

## Author Contributions

All authors contributed equally to the reported research and writing of the paper.

## Conflicts of Interest

The authors declare no conflict of interest.

## References

1. Heathcote, M.J. *J & P Transformer Book*; Newnes: Oxford, UK, 2007.

2. Darabad, V.P.; Vakilian, M.; Blackburn, T.R.; Phung, B.T. An efficient PD data mining method for power transformer defect models using SOM technique. *Int. J. Electr. Power Energy Syst.* **2015**, *71*, 373–382.
3. Bayliss, C.R.; Hardy, B.J. Power Transformers. In *Transmission and Distribution Electrical Engineering*, 4th ed.; Bayliss, C.R., Hardy, B.J., Eds.; Newnes: Oxford, UK, 2012; pp. 543–614.
4. Cennamo, N.; Maria, L.D.; D’Agostino, G.; Zeni, L.; Pesavento, M. Monitoring of low levels of furfural in power transformer oil with a sensor system based on a POF-MIP platform. *Sensors* **2015**, *15*, 8499–8511.
5. Degeneff, B.C. 3—Power Transformers. In *The Electrical Engineering Handbook*; Chen, W.-K., Ed.; Academic Press: Burlington, VT, USA, 2005; pp. 715–720.
6. Sen, P.K.; Pansuwan, S. Overloading and loss-of-life assessment guidelines of oil-cooled transformers. In Proceedings of the 2001 Rural Electric Power Conference, Little Rock, AR, USA, 29 April–1 May 2001.
7. United States Department of The Interior—Bureau of Reclamation. *Facilities Instructions, Standards, and Techniques—Volume 1–5—Permissible Loading of Oil-Immersed Transformers and Regulators*; Facilities Engineering Branch—Denver Office: Denver, CO, USA, 1991.
8. Tenbohlen, S.; Stirl, T.; Stach, M. Assessment of overload capacity of power transformers by on-line monitoring systems. In Proceedings of the IEEE Power Engineering Society Winter Meeting, Columbus, OH, USA, 28 January–1 February 2001; pp. 329–334.
9. Fu, W.; McCalley, J.D.; Vittal, V. Risk assessment for transformer loading. *IEEE Trans. Power Syst.* **2001**, *16*, 346–353.
10. Rashid, N. *Short-Time Overloading of Power Transformers*; Royal Institute of Technology KTH (Kungliga Tekniska högskolan): Stockholm, Sweden, 2011.
11. *IEEE Guide for Loading Mineral-Oil-Immersed*; IEEE Standard C57.91-1995; IEEE: New York, NY, USA, 1996.
12. *Loading Guide for Oil-immersed Power Transformers*; IEC 60076-7; International Electrotechnical Commission (IEC): Geneva, Switzerland, 2007.
13. Hilshey, A.D.; Hines, P.D.H.; Rezaei, P.; Dowds, J.R. Estimating the impact of electric vehicle smart charging on distribution transformer aging. *IEEE Trans. Smart Grid* **2013**, *4*, 905–913.
14. Willis, H.L. *Power Distribution Planning Reference Book*; CRC Press: Boca Raton, FL, USA, 2004.
15. Humayun, M.; Safdarian, A.; Degefa, M.Z.; Lehtonen, M. Demand response for operational life extension and efficient capacity utilization of power transformers during contingencies. *IEEE Trans. Power Syst.* **2015**, *30*, 2160–2169.
16. Humayun, M.; Degefa, M.Z.; Safdarian, A.; Lehtonen, M. Utilization improvement of transformers using demand response. *IEEE Trans. Power Deliv.* **2015**, *30*, 202–210.
17. Power Systems Engineering Research Center. *Transformer Overloading and Assessment of Loss-of-Life for Liquid-Filled Transformers*; Colorado School of Mines and Texas A & M University: Tempe, AZ, USA, 2011.
18. Tang, W.H.; Wu, Q.H. *Condition Monitoring and Assessment of Power Transformers Using Computational Intelligence*; Springer-Verlag: Berlin, Germany, 2011.
19. Yoshida, H.; Suzuki, T. Drying process of insulating materials of transformers. *IEEE Trans. Electr. Insul.* **1985**, *EI-20*, 609–618.

20. ABB Power. *Distribution Transformers*; Cross Advertising: Zürich, Switzerland, 2001.
21. Pierce, L.W. Specifying and loading cast-resin transformers. *IEEE Trans. Ind. Appl.* **1993**, *29*, 590–599.
22. Siemens AG. *Transformers—Power Engineering Guide*, 7th ed.; Siemens Energy Sector: Erlangen, Germany, 2014.
23. Mitsubishi Electric Corporation. *Large Power Transformers*; Mitsubishi Electric Corporation: Tokyo, Japan, 2005.
24. Gradnik, T.; Končan-Gradnik, M. Cooling system optimization and expected lifetime of large power transformers. In Proceedings of the 2006 IASME/WSEAS International Conference on Energy & Environmental Systems, Chalkida, Greece, 8–10 May 2006; pp. 194–201.
25. *IEEE Standard Terminology for Power and Distribution Transformers*; IEEE Std C57.12.80-2010 (Revision of IEEE Std C57.12.80-2002); IEEE: New York, NY, USA, 2010.
26. Pezeshki, H.; Wolfs, P.J.; Ledwich, G. Impact of High PV Penetration on Distribution Transformer Insulation Life. *IEEE Trans. Power Deliv.* **2014**, *29*, 1212–1220.
27. Godina, R.; Paterakis, N.G.; Erdinc, O.; Rodrigues, E.M.G.; Catalão, J.P.S. Electric vehicles home charging impact on a distribution transformer in a Portuguese island. In Proceedings of the International Symposium on Smart Electric Distribution Systems and Technologies, Vienna, Austria, 8–11 September 2015.
28. Godina, R.; Paterakis, N.G.; Erdinc, O.; Rodrigues, E.M.G.; Catalão, J.P.S. Impact of EV charging-at-work on an industrial client distribution transformer in a Portuguese island. In Proceedings of the 2015 Australasian Universities Power Engineering Conference (AUPEC), Wollongong, Australia, 27–30 September 2015.
29. Qian, K.; Zhou, C.; Yuan, Y. Impacts of high penetration level of fully electric vehicles charging loads on the thermal ageing of power transformers. *Int. J. Electr. Power Energy Syst.* **2015**, *65*, 102–112.
30. Turker, H.; Bacha, S.; Chatroux, D.; Hably, A. Low-voltage transformer loss-of-life assessments for a high penetration of plug-in hybrid electric vehicles (PHEVs). *IEEE Trans. Power Deliv.* **2012**, *27*, 1323–1331.
31. Tripathy, S.C.; Lakervi, E. Evaluation of transformer overloading capability. *Eur. Trans. Electr. Power* **2005**, *15*, 455–464.
32. *IEEE Recommended Practice for Establishing Liquid-Filled and Dry-Type Power and Distribution Transformer Capability When Supplying Nonsinusoidal Load Currents*; IEEE Standard C57.110-2008; IEEE: New York, NY, USA, 2008.
33. Bérubé, J.-N.; Aubin, J.; McDermid, W. Recent Development in Transformer Winding Temperature Determination; Neoptix Inc.: Québec, QC, Canada. Available online: [http://www.neoptix.com/literature/v1109r1\\_Art\\_Recent\\_dev\\_in\\_windings\\_temp.pdf](http://www.neoptix.com/literature/v1109r1_Art_Recent_dev_in_windings_temp.pdf) (accessed on 21 October 2015).
34. *Guide for the Definition of Thermal Duplicate Liquid-Immersed Distribution, Power and Regulating Transformer*; IEEE PC57.145; IEEE: New York, NY, USA, 2002.
35. Aravinthan, V.; Jewell, W. Controlled electric vehicle charging for mitigating impacts on distribution assets. *IEEE Trans. Smart Grid* **2015**, *6*, 999–1009.
36. Seier, A.; Hines, P.D.H.; Frolik, J. Data-driven thermal modeling of residential service transformers. *IEEE Trans. Smart Grid* **2015**, *6*, 1019–1025.



37. Shuaib, K.; Zhang, L.; Gaouda, A.; Abdel-Hafez, M. A PEV charging service model for smart grids. *Energies* **2012**, *5*, 4665–4682.
38. Qian, K.; Zhou, C.; Allan, M.; Yuan, Y. Modeling of load demand due to EV battery charging in distribution systems. *IEEE Trans. Power Syst.* **2011**, *26*, 802–810.
39. Gong, Q.; Midlam-Mohler, S.; Marano, V.; Rizzoni, G. Study of PEV charging on residential distribution transformer life. *IEEE Trans. Smart Grid* **2012**, *3*, 404–412.
40. Rutherford, M.J.; Yousefzadeh, V. The Impact of Electric Vehicle Battery Charging on Distribution Transformers. In Proceedings of the 26th Annual IEEE Applied Power Electronics Conference and Exposition (APEC), Fort Worth, TX, USA, 5–9 February 2012; pp. 396–400.
41. Vicini, R.; Micheloud, O.; Kumar, H.; Kwasinski, A. Transformer and home energy management systems to lessen electrical vehicle impact on the grid. *IET Gener. Transm. Distrib.* **2012**, *6*, 1202–1208.
42. Sexauer, J.M.; McBee, K.D.; Bloch, K.A. Applications of probability model to analyze the effects of electric vehicle chargers on distribution transformers. *IEEE Trans. Power Syst.* **2013**, *28*, 847–854.
43. Sexauer, J.M.; McBee, K.D.; Bloch, K.A. Applications of probability model to analyze the effects of electric vehicle chargers on distribution transformers. In Proceedings of the IEEE Electrical Power and Energy Conference (EPEC), Winnipeg, MB, USA, 3–5 October 2011; pp. 290–295.
44. Gong, Q.; Midlam-Mohler, S.; Serra, E.; Marano, V.; Rizzoni, G. PEV charging control considering transformer life and experimental validation of a 25 kVA distribution transformer. *IEEE Trans. Smart Grid* **2015**, *6*, 648–656.
45. Turker, H.; Bacha, S.; Chatroux, D.; Hably, A. Aging Rate of Low Voltage Transformer for a High Penetration of Plug-in Hybrid Electric Vehicles (PHEVs). In Proceedings of the 2012 IEEE PES Innovative Smart Grid Technologies (ISGT), Washington, DC, USA, 16–20 January 2012; pp. 1–8.
46. Turker, H.; Bacha, S.; Hably, A. Rule-based charging of plug-in electric vehicles (PEVs): impacts on the aging rate of low-voltage transformers. *IEEE Trans. Power Deliv.* **2014**, *29*, 1012–1019.
47. Turker, H.; Florescu, A.; Bacha, S.; Chatroux, D. Load rates of low voltage transformers and medium voltage profile assessments on a real distribution electric grid based on average Daily Load Profile (DLP) of a housing for a high penetration of plug-in hybrid electric vehicles (PHEVs). In Proceedings of the 2011 IEEE Vehicle Power and Propulsion Conference (VPPC), Chicago, IL, USA, 6–9 September 2011; pp. 1–8.
48. Soto, D.M.; Balathandayuthapani, S.; Edrington, C.S. Mitigation of PHEV charging impact on transformers via a PV-APF harmonic compensation technique: Application to V2G integration. In Proceedings of the 2011 IEEE Vehicle Power and Propulsion Conference (VPPC), Chicago, IL, USA, 6–9 September 2011; pp. 1–5.
49. Geiles, T.J.; Islam, S. Impact of PEV charging and rooftop PV penetration on distribution transformer life. In Proceedings of the 2013 IEEE Power and Energy Society General Meeting (PES), Vancouver, BC, Canada, 21–25 July 2013; pp. 1–5.
50. Weckx, S.; D’Hulst, R.; Claessens, B.; Driesensam, J. Multiagent charging of electric vehicles respecting distribution transformer loading and voltage limits. *IEEE Trans. Smart Grid* **2014**, *5*, 2857–2867.

51. Kazerooni, M.; Kar, N.C. Optimal Load Management of EV Battery Charging and Optimization of Harmonic Impacts on Distribution Transformers. In Proceedings of the 25th IEEE Canadian Conference on Electrical & Computer Engineering (CCECE), Montreal, QC, Canada, 29 April–2 May 2012; pp. 1–4.
52. Kazerooni, M.; Kar, N.C. Impact Analysis of EV Battery Charging on the Power System Distribution Transformers. In Proceedings of the 2012 IEEE International Electric Vehicle Conference (IEVC), Greenville, SC, USA, 4–8 March 2012; pp. 1–6.
53. Gomez, J.C.; Morcos, M.M. Impact of EV battery chargers on the power quality of distribution systems. *IEEE Trans. Power Deliv.* **2003**, *18*, 975–981.
54. Gong, Q.; Midlam-Mohler, S.; Marano, V.; Rizzoni, G. PEV Charging Impact on Residential Distribution Transformer Life. In Proceedings of the 2011 IEEE Energytech, Cleveland, OH, USA, 25–26 May 2011; pp. 1–6.
55. Gong, Q.; Midlam-Mohler, S.; Marano, V.; Rizzoni, G. Distribution of PEV Charging Resources to Balance Transformer Life and Customer Satisfaction. In Proceedings of the 2012 IEEE International Electric Vehicle Conference (IEVC), Greenville, SC, USA, 4–8 March 2012; pp. 1–7.
56. Masoum, M.A.S.; Moses, P.S.; Smedley, K.M. Distribution Transformer Losses and Performance in Smart Grids with Residential Plug-In Electric Vehicles. In Proceedings of the 2011 IEEE PES Innovative Smart Grid Technologies (ISGT), Hilton Anaheim, CA, USA, 17–19 January 2011; pp. 1–7.
57. Masoum, M.A.S.; Moses, P.S.; Hajforoosh, S. Distribution Transformer Stress in Smart Grid with Coordinated Charging of Plug-In Electric Vehicles. In Proceeding of the 2012 IEEE PES Innovative Smart Grid Technologies (ISGT), Washington, DC, USA, 16–20 January 2012; pp. 1–8.
58. Masoum, A.S.; Abu-Siada, A.; Islam, S. Impact of Uncoordinated and Coordinated Charging of Plug-In Electric Vehicles on Substation Transformer in Smart Grid with Charging Stations. In Proceedings of the 2011 IEEE PES Innovative Smart Grid Technologies Asia (ISGT), Perth, Australia, 13–16 November 2011; pp. 1–7.
59. Moghbel, M.; Masoum, M.A.S.; Shahnia, F.; Moses, P. Distribution Transformer Loading in Unbalanced Three-Phase Residential Networks with Random Charging of Plug-In Electric vehicles. In Proceedings of the 2012 22nd Australasian Universities Power Engineering Conference (AUPEC), Bali, Indonesia, 26–29 September 2012; pp. 1–6.
60. Moses, P.S.; Masoum, M.A.S.; Hajforoosh, S. Overloading of Distribution Transformers in Smart Grid Due to Uncoordinated Charging of Plug-In Electric Vehicles. In Proceedings of the 2012 IEEE PES Innovative Smart Grid Technologies (ISGT), Washington, DC, USA, 16–20 January 2012; pp. 1–6.
61. Moses, P.S.; Masoum, M.A.S.; Smedley, K.M. Harmonic Losses and Stresses of Nonlinear Three-Phase Distribution Transformers Serving Plug-In Electric Vehicle Charging Stations. In Proceedings of the 2011 IEEE PES Innovative Smart Grid Technologies (ISGT), Anaheim, CA, USA, 17–19 January 2011; pp. 1–6.
62. Masoum, A.S.; Deilami, S.; Moses, P.S.; Abu-Siada, A. Impacts of Battery Charging Rates of Plug-in Electric Vehicle on Smart Grid Distribution Systems. In Proceedings of the 2010 IEEE PES Innovative Smart Grid Technologies Conference Europe (ISGT Europe), Gothenburg, Sweden, 11–13 October 2010; pp. 1–6.

63. Razeghi, G.; Zhang, L.; Brown, T.; Samuelson, S. Impacts of Plug-In Hybrid Electric Vehicles on a Residential Transformer Using Stochastic and Empirical Analysis. *J. Power Sources* **2014**, *252*, 277–285.
64. Agah, S.M.M.; Abbasi, A. The Impact of Charging Plug-In Hybrid Electric Vehicles on Residential Distribution Transformers. In Proceedings of the 2012 2nd Iranian Conference on Smart Grids (ICSG), Tehran, Iran, 24–25 May 2012; pp. 1–5.
65. Gerkenmeyer, C.; Kintner-Meyer, M.C.W.; DeSteese, J.G. *Technical Challenges of Plug-In Hybrid Electric Vehicles and Impacts to the US Power System: Distribution System Analysis*; Pacific Northwest National Laboratory: Richland, WA, USA, 2010.
66. Alonso, M.; Amaris, H.; Germain, J.G.; Galan, J.M. Optimal charging scheduling of electric vehicles in smart grids by Heuristic algorithms. *Energies* **2014**, *7*, 2449–2475.
67. Shao, S.; Pipattanasomporn, M.; Rahman, S. Challenges of PHEV Penetration to the Residential Distribution Network. In Proceedings of the 2009 IEEE Power and Energy Society General Meeting, Calgary, AB, Canada, 26–30 July 2009; pp. 26–30.
68. Gong, Q.; Midlam-Mohler, S.; Serra, E.; Marano, V.; Rizzoni, G. Distribution Transformer Tests for PEV Smart Charging Control. In Proceedings of the 2012 IEEE Energytech, Cleveland, OH, USA, 29–31 May 2012; pp. 1–6.
69. Marano, V.; Tulpule, P.; Gong, Q.; Martinez, A.; Midlam-Mohler, S.; Rizzoni, G. Vehicle Electrification: Implications on Generation and Distribution Network. In Proceedings of the 2011 International Conference on Electrical Machines and Systems (ICEMS), Beijing, China, 20–23 August 2011; pp. 1–6.
70. Gong, Q.; Midlam-Mohler, S.; Marano, V.; Rizzoni, G. Optimal Control of PEV Charging Based on Residential Base Load Prediction. In Proceedings of the ASME 2011 Dynamic Systems and Control Conference, Arlington, VA, USA, 31 October–2 November 2011; pp. 727–734.
71. Argade, S.; Aravinthan, V.; Jewell, W. Probabilistic Modeling of EV Charging and Its Impact on Distribution Transformer Loss of Life. In Proceedings of the 2012 IEEE International Electric Vehicle Conference (IEVC), Greenville, SC, USA, 4–8 March 2012; pp. 1–8.
72. Aravinthan, V.; Argade, S. Optimal Transformer Sizing with the Presence of Electric Vehicle Charging. In Proceedings of the 2014 IEEE PES T&D Conference and Exposition, Chicago, IL, USA, 14–17 April 2014.
73. Kuss, M.; Markel, T.; Kramer, W. Application of Distribution Transformer Thermal Life Models to Electrified Vehicle Charging Loads Using Monte-Carlo Method. In Proceedings of the 25th World Battery, Hybrid and Fuel Cell Electric Vehicle Symposium and Exhibition, Shenzhen, China, 5–9 November 2010.
74. Taylor, J.; Maitra, A.; Alexander, M.; Brooks, D.; Duvall, M. Evaluation of the Impact of Plug-In Electric Vehicle Loading on Distribution System Operations. In Proceedings of the 2009 IEEE Power and Energy Society General Meeting, Calgary, AB, Canada, 26–30 July 2009; pp. 1–6.
75. Pezeshki, H.; Wolfs, P. Impact of High PV Penetration on Distribution Transformer Life Time. In Proceedings of the 2013 IEEE Power and Energy Society General Meeting (PES), Vancouver, BC, Canada, 21–25 July 2013.

76. Hasanzadeh, A.; Edrington, C.S.; Bevis, T. Comprehensive Study of Power Quality Criteria Generated by PV Converters and Their Impacts on Distribution Transformers. In Proceedings of the 38th Annual Conference on IEEE Industrial Electronics Society, Montreal, QC, USA, 25–28 October 2012; pp. 5820–5826.
77. Rajender, K.; Rajapandiyam, K.; Vallisaranya. Transformer rating for solar PV Plants Based on Overloading Capability as Per Guidelines. In Proceedings of the 2014 IEEE Region 10 Humanitarian Technology Conference (R10-HTC), Chennai, India, 6–9 August 2014; pp. 19–24.
78. Agah, S.M.M.; Askarian Abyaneh, H. Quantification of the Distribution Transformer Life Extension Value of Distributed Generation. *IEEE Trans. Power Deliv.* **2011**, *26*, 1820–1828.
79. Martin, D.; Goodwin, S.; Krause, O.; Saha, T. The Effect of PV on Transformer Ageing: University of Queensland’s Experience. In Proceedings of the 2014 Australasian Universities Power Engineering Conference (AUPEC), Perth, Australia, 28 September–1 October 2014.
80. Masoum, A.S.; Moses, P.S.; Masoum, M.A.S.; Abu-Siada, A. Impact of Rooftop PV Generation on Distribution Transformer and Voltage Profile of Residential and Commercial Networks. In Proceedings of the 2012 IEEE PES Innovative Smart Grid Technologies (ISGT), Washington, DC, USA, 16–20 January 2012; pp. 1–7.
81. Hamzeh, M.; Vahidi, B.; Askarian-Abyaneh, H. Reliability evaluation of distribution transformers with high penetration of distributed generation. *Int. J. Electr. Power Energy Syst.* **2015**, *73*, 163–169.
82. Agah, S.M.M.; Abyaneh, H.A. Distribution transformer loss-of-life reduction by increasing penetration of distributed generation. *IEEE Trans. Power Deliv.* **2011**, *26*, 1128–1136.
83. Awadallah, M.A.; Xu, T.; Venkatesh, B.; Singh, B.N. On the effects of solar panels on distribution transformers. *IEEE Trans. Power Deliv.* **2015**, in press.
84. Jimenez, H.; Calleja, H.; González, R.; Huacuz, J.; Lagunas, J. The impact of photovoltaic systems on distribution transformer: A case study. *Energy Convers. Manag.* **2006**, *47*, 311–321.
85. Degefa, M.Z.; Humayun, M.; Safdarian, A.; Koivisto, M.; Millar, R.J.; Lehtonen, M. Unlocking distribution network capacity through real-time thermal rating for high penetration of DGs. *Electr. Power Syst. Res.* **2014**, *117*, 36–46.
86. Jargstorf, J.; Vanthournout, K.; de Rybel, T.; van Hertem, D. Effect of Demand Response on Transformer Lifetime Expectation. In Proceedings of the 3rd IEEE PES International Conference and Exhibition on Innovative Smart Grid Technologies (ISGT Europe), Berlin, Germany, 14–17 October 2012; pp. 1–8.
87. Shiri, A.; Gholami, A.; Shoulaie, A. Investigation of the ambient temperature effects on transformer’s insulation life. *Electr. Eng.* **2011**, *93*, 193–197.
88. Ravetta, C.; Samanna, M.; Stucchi, A.; Bossi, A. Thermal behavior of distribution transformers in summertime and severe loading conditions. In Proceedings of the 19th International Conference on Electricity Distribution, Vienna, Germany, 21–24 May 2007.
89. Lee, M.; Abdullah, H.A.; Jofriet, J.C.; Patel, D.; Fahrioglu, M. Air temperature effect on thermal models for ventilated dry-type transformers. *Electr. Power Syst. Res.* **2011**, *81*, 783–789.
90. Agah, S.M.M.; Abyaneh, H.A. Effect of modeling non-normality and stochastic dependence of variables on distribution transformer loss of life inference. *IEEE Trans. Power Deliv.* **2012**, *27*, 1700–1709.

91. Stahlhut, J.W.; Heydt, G.T.; Selover, N.J. A Preliminary assessment of the impact of ambient temperature rise on distribution transformer loss of life. *IEEE Trans. Power Deliv.* **2008**, *23*, 2000–2007.
92. Sathyanarayana, B.R.; Heydt, G.T.; Dyer, M.L. Distribution transformer life assessment with ambient temperature rise projections. *Electr. Power Compon. Syst.* **2009**, *37*, 1005–1013.
93. Elmoudi, A. Thermal Modeling and Simulation of Distribution Transformers. In Proceedings of the 5th International Multi-Conference on Systems, Signals and Devices, Amman, Jordan, 20–22 July 2008; pp. 1–4.
94. Yun, S.-Y.; Park, C.-H.; Song, I.-K. Development of overload evaluation system for distribution transformers using load monitoring data. *Int. J. Electr. Power Energy Syst.* **2013**, *44*, 60–69.
95. Lachman, M.F.; Griffin, P.J.; Walter, W.; Wilson, A. Real-time dynamic loading and thermal diagnostic of power transformers. *IEEE Trans. Power Deliv.* **2003**, *18*, 142–148.
96. Susa, D.; Lehtonen, M.; Nordman, H. Dynamic thermal modeling of power transformers. *IEEE Trans. Power Deliv.* **2005**, *20*, 197–204.
97. Awadallah, S.K.E.; Milanovic, J.V.; Jarman, P.N. The influence of modeling transformer age related failures on system reliability. *IEEE Trans. Power Syst.* **2015**, *30*, 970–979.
98. Susa, D.; Nordman, H. A simple model for calculating transformer hot-spot temperature. *IEEE Trans. Power Deliv.* **2009**, *24*, 1257–1265.
99. Jardini, J.A.; Schmidt, H.P.; Tahan, C.M.V.; de Oliveira, C.C.B.; Ahn, S.U. Distribution transformer loss of life evaluation: A novel approach based on daily load profiles. *IEEE Trans. Power Deliv.* **2000**, *15*, 361–366.
100. Radakovic, Z.; Feser, K. A new method for the calculation of the hot-spot temperature in power transformers with ONAN cooling. *IEEE Trans. Power Deliv.* **2003**, *18*, 1284–1292.
101. Radakovic, Z.; Cardillo, E.; Feser, K. The influence of transformer loading to the ageing of the oil–paper insulation. In Proceedings of the 13th International Symposium High Voltage Engineering, Rotterdam, The Netherlands, 25–29 August 2003.
102. Jardini, J.A.; Tahan, C.M.V.; Ahn, S.U.; Ferrari, E.L. Distribution transformer loading evaluation based on load profiles measurements. *IEEE Trans. Power Deliv.* **1997**, *12*, 1766–1770.
103. Su, X.; Chen, W.; Pan, C.; Zhou, Q.; Teng, L. A Simple Thermal Model of Transformer Hot Spot Temperature Based on Thermal-Electrical Analogy. In Proceedings of the International Conference on High Voltage Engineering and Application (ICHVE), Shanghai, China, 17–20 September 2012.
104. Elmoudi, A.; Palola, J.; Lehtonen, M. A Transformer Thermal Model for Use in an On-Line Monitoring and Diagnostic System. In Proceedings of the 2006 IEEE PES Power Systems Conference and Exposition, Atlanta, GA, USA, 29 October–1 November 2006; pp. 1092–1096.
105. Khederzadeh, M. Transformer Overload Management and Condition Monitoring. In Proceedings of the Conference Record of the 2008 IEEE International Symposium on Electrical Insulation, Vancouver, BC, Canada, 9–12 June 2008; pp. 116–119.
106. Elmoudi, A.; Lehtonen, M.; Nordman, H. Thermal model for power transformers dynamic loading. In Proceedings of the Conference Record of the 2006 IEEE International Symposium on Electrical Insulation, Toronto, ON, Canada, 11–14 June 2006; pp. 214–217.
107. Weekes, T.; Molinski, T.; Li, X.; Swift, G. Risk assessment using transformer loss of life data. *IEEE Electr. Insul. Mag.* **2004**, *20*, 27–31.

108. Zhang, X.; Gockenbach, E. Determination of the thermal aging factor for life expectancy of 550 kV transformers with a preventive test. *IEEE Trans. Dielectr. Electr. Insul.* **2013**, *20*, 1984–1991.
109. Martins, M.A.; Fialho, M.; Martins, J.; Soares, M.; Cristina, M.; Lopes, R.C.; Campelo, H.M.R. Power transformer end-of-life assessment-pracana case study. *IEEE Electr. Insul. Mag.* **2011**, *27*, 15–26.
110. Abu-Elanien, A.E.B.; Salama, M.M.A. A Monte Carlo approach for calculating the thermal lifetime of transformer insulation. *Int. J. Electr. Power Energy Syst.* **2012**, *43*, 481–487.
111. Miyagi, K.; Oe, E.; Yamagata, N.; Miyahara, H. Thermal aging characteristics of insulation paper in mineral oil in overloaded operation of transformers. *Electr. Eng. Jpn.* **2013**, *182*, 1–8.
112. Wouters, P.A.A.F.; van Schijndel, A.; Wetzer, J.M. Remaining lifetime modeling of power transformers: individual assets and fleets. *IEEE Electr. Insul. Mag.* **2011**, *27*, 45–51.
113. Walling, R.; Shattuck, G.B. Distribution Transformer Thermal Behavior and Aging in Local Delivery Distribution Systems. In Proceedings of the 19th International Conference on Electricity Distribution, CIRED, Vienna, Germany, 21–24 May 2007.
114. Suechoey, B.; Tadsuan, S.; Thammarat, C.; Leelajindakraierk, M. An Analysis of Temperature and Pressure on Loading Oil-Immersed Distribution Transformer. In Proceedings of the 7th International Power Engineering Conference, Singapore, 29 November–2 December 2005; pp. 634–638.
115. McNutt, W.J. Insulation thermal life considerations for transformer loading guides. *IEEE Trans. Power Deliv.* **1992**, *7*, 392–401.
116. Souza, L.M.; Lemos, A.P.; Caminhas, W.M.; Boaventura, W.C. Thermal modeling of power transformers using evolving fuzzy systems. *Eng. Appl. Artif. Intell.* **2012**, *25*, 980–988.
117. Koufakis, E.I.; Karagiannopoulos, C.G.; Bourkas, P.D. Thermal coefficient measurements of the insulation in distribution transformers of a 20 kV network. *Measurement* **2008**, *41*, 10–19.
118. Swift, G.; Molinski, T.S.; Lehn, W. A fundamental approach to transformer thermal modeling. I. Theory and equivalent circuit. *IEEE Trans. Power Deliv.* **2001**, *16*, 171–175.
119. Swift, G.; Molinski, T.S.; Bray, R.; Menzies, R. A fundamental approach to transformer thermal modeling. II. Field verification. *IEEE Trans. Power Deliv.* **2001**, *16*, 176–180.
120. Susa, D.; Lehtonen, M.; Nordman, H. Dynamic thermal modeling of distribution transformers. *IEEE Trans. Power Deliv.* **2005**, *20*, 1919–1929.
121. Nordman, H.; Rafsback, N.; Susa, D. Temperature responses to step changes in the load. *IEEE Trans. Power Deliv.* **2003**, *18*, 1110–1117.
122. Jauregui-Rivera, L.; Mao, X.; Tylavsky, D.J. Improving reliability assessment of transformer thermal top-oil model parameters estimated from measured data. *IEEE Trans. Power Deliv.* **2009**, *24*, 169–176.
123. Bicen, Y.; Cilliyuz, Y.; Aras, F.; Aydugan, G. An Assessment on Aging Model of IEEE/IEC Standards for Natural and Mineral Oil-Immersed Transformer. In Proceedings of the 2011 IEEE International Conference on Dielectric Liquids (ICDL), Trondheim, Norway, 26–30 June 2011; pp. 1–4.
124. Galdi, V.; Ippolito, L.; Piccolo, A.; Vaccaro, A. Neural diagnostic system for transformer thermal overload protection. *IEEE Proc. Electr. Power Appl.* **2000**, *147*, 415–421.
125. Singh, R.; Singh, A. Aging of Distribution Transformers Due to Harmonics. In Proceedings of the 14th International Conference on Harmonics and Quality of Power (ICHQP), Bergamo, Italy, 26–29 September 2010; pp. 1–8.

126. Elmoudi, A.; Lehtonen, M.; Nordman, H. Effect of Harmonics on Transformers Loss of Life. In Proceedings of the Conference Record of the 2006 IEEE International Symposium on Electrical Insulation, Toronto, ON, Canada, 11–14 June 2006; pp. 408–411.
127. Shafiee Rad, M.; Kazerooni, M.; Ghorbany, M.J.; Mokhtari, H. Analysis of the Grid Harmonics and Their Impacts on Distribution Transformers. In Proceedings of the 2012 IEEE Power and Energy Conference at Illinois (PECI), Champaign, IL, USA, 24–25 February 2012; pp. 1–5.
128. Said, D.M.; Nor, K.M. Effects of Harmonics on Distribution Transformers. In Proceedings of the Australasian Power Engineering Conference, Sydney, Australia, 14–17 December 2008; pp. 1–5.
129. Taheri, S.; Gholami, A.; Fofana, I.; Taheri, H. Modeling and simulation of transformer loading capability and hot spot temperature under harmonic conditions. *Electr. Power Syst. Res.* **2012**, *86*, 68–75.
130. Moses, P.S.; Masoum, M.A.S. Three-Phase Asymmetric transformer aging considering voltage-current harmonic interactions, unbalanced nonlinear loading, magnetic couplings, and hysteresis. *IEEE Trans. Energy Convers.* **2012**, *27*, 318–327.
131. Faria, P.; Vale, Z.; Baptista, J. Demand response programs design and use considering intensive penetration of distributed generation. *Energies* **2015**, *8*, 6230–6246.
132. Lucas, A.; Bonavitacola, F.; Kotsakis, E.; Fulli, G. *An Experimental Approach for Assessing the Harmonic Impact of Fast Charging Electric Vehicles on the Distribution Systems*; SETIS—Publications Office of the European Union: Luxembourg, 2015.
133. Mena, A.J.G.; García, J.A.M. An efficient approach for the siting and sizing problem of distributed generation. *Int. J. Electr. Power Energy Syst.* **2015**, *69*, 167–172.
134. Bagheri, A.; Monsef, H.; Lesani, H. Integrated distribution network expansion planning incorporating distributed generation considering uncertainties, reliability, and operational conditions. *Int. J. Electr. Power Energy Syst.* **2015**, *73*, 56–70.
135. Karatepe, E.; Ugranlı, F.; Hiyama, T. Comparison of single- and multiple-distributed generation concepts in terms of power loss, voltage profile, and line flows under uncertain scenarios. *Renew. Sustain. Energy Rev.* **2015**, *48*, 317–327.
136. Groot, K. Chapter 6—The Impact of Distributed Generation on European Power Utilities. In *Distributed Generation and Its Implications for the Utility Industry*; Sioshansi, F.P., Ed.; Academic Press: Boston, MA, USA, 2014; pp. 123–139.
137. Gellings, C.W. As the Role of the Distributor Changes, so Will the Need for New Technology. In *Distributed Generation and Its Implications for the Utility Industry*; Sioshansi, F.P., Ed.; Academic Press: Boston, MA, USA, 2014; pp. 97–121.
138. Nissen, M.B. High performance development as distributed generation. *IEEE Potentials* **2009**, *26*, 25–31.
139. Jochem, P.; Babrowski, S.; Fichtner, W. Assessing CO<sub>2</sub> emissions of electric vehicles in Germany in 2030. *Transp. Res. Part A Policy Pract.* **2015**, *78*, 68–83.
140. Schuller, A. Charging Coordination Paradigms of Electric Vehicles. In *Plug in Electric Vehicles in Smart Grids*; Springer: Berlin, Germany, 2015; pp. 1–21.
141. Das, R.; Thirugnanam, K.; Kumar, P.; Lavudiya, R.; Singh, M. Mathematical modeling for economic evaluation of electric vehicle to smart grid interaction. *IEEE Trans. Smart Grid* **2014**, *5*, 712–721.

142. Reggi, L.; Scicchitano, S. Are EU regional digital strategies evidence-based? An analysis of the allocation of 2007–13 Structural Funds. *Telecommun. Policy* **2014**, *38*, 530–538.
143. Fedirchuk, D.; Rebizant, C. Managing transformer overload—Smart relays. *IEEE Can. Rev.* **2000**, *35*, 25–28.
144. Weekes, T.; Molinski, T.; Swift, G. Transient transformer overload ratings and protection. *IEEE Electr. Insul. Mag.* **2004**, *20*, 32–35.
145. Nylén, R. *Power Transformer Protection—Application Guide*; ABB Relays: Västerås, Sweden, 1988.
146. *IEEE Guide for Protective Relay Applications to Power Transformers*; IEEE Std C37.91-2000; IEEE: New York, NY, USA, 2000.
147. Lee, B.E.; Park, J.-W.; Crossley, P.A.; Kang, Y.C. Induced voltages ratio-based algorithm for fault detection, and faulted phase and winding identification of a three-winding power transformer. *Energies* **2014**, *7*, 6031–6049.
148. Molinski, T. *Minimizing the Life Cycle Cost of Power Transformers*; CIGRE Colloquium: Dublin, Ireland, 2001.
149. Bergman, W.J. Equipment Monitoring Selection as a Part of Substation Automation. In Proceedings of the IEEE Power Engineering Society 1999 Winter Meeting, New York, NY, USA, 31 January–4 February 1999; pp. 971–973.
150. Reddy, P.A.; Rajpurohit, B.S. On-line Monitoring of Winding Parameters for Single-Phase Transformers. In Proceedings of the IEEE 6th India International Conference on Power Electronics (IICPE), Kurukshetra, India, 8–10 December 2014.
151. Serveron Corporation. *Serveron White Paper: DGA Diagnostic Methods*; Serveron Corporation, A BPL Global Company: Hillsboro, OH, USA, 2007.
152. Singh, S.; Bandyopadhyay, M.N. Dissolved gas analysis technique for incipient fault diagnosis in power transformers: A bibliographic survey. *IEEE Electr. Insul. Mag.* **2010**, *26*, 41–46.
153. Abu-Siada, A.; Islam, S. A new approach to identify power transformer criticality and asset management decision based on dissolved gas-in-oil analysis. *IEEE Trans. Dielectr. Electr. Insul.* **2012**, *19*, 1007–1012.
154. *Mineral Oil-Impregnated Electrical Equipment in Service—Guide to the Interpretation of Dissolved and Free Gases Analysis*; IEC 60599; International Electrotechnical Commission (IEC): Geneva, Switzerland, 1999.
155. *Guide for the Interpretation of Gases Generated in Oil-Immersed Transformers*; IEEE Std C57.104; IEEE: New York, NY, USA, 1991.
156. Duval, M.; Dukarm, J. Improving the reliability of transformer gas-in-oil diagnosis. *IEEE Electr. Insul. Mag.* **2005**, *21*, 21–27.
157. Akbari, A.; Setayeshmehr, A.; Borsi, H.; Gockenbach, E.; Fofana, I. Intelligent agent-based system using dissolved gas analysis to detect incipient faults in power transformers. *IEEE Electr. Insul. Mag.* **2010**, *26*, 27–40.