

# Risk-Averse Optimal Energy and Reserve Scheduling for Virtual Power Plants Incorporating Demand Response Programs

Mostafa Vahedipour-Dahraie, Homa Rashidizade-Kermani, Miadreza Shafie-khah, *Senior Member, IEEE*,  
João P. S. Catalão, *Senior Member, IEEE*

**Abstract**—This paper addresses the optimal bidding strategy problem of a virtual power plant (VPP) participating in the day-ahead (DA), real-time (RT) and spinning reserve (SR) markets (SRMs). The VPP comprises a number of dispatchable energy resources (DERs), renewable energy resources (RESs), energy storage systems (ESSs) and a number of customers with flexible demand. A two-stage risk-constrained stochastic problem is formulated for the VPP scheduling, where the uncertainty lies in the energy and reserve prices, RESs production, load consumption, as well as calls for reserve services. Based on this model, the VPP bidding/offering strategy in the DA market (DAM), RT market (RTM) and SRM is decided aiming to maximize the VPP profit considering both supply and demand-sides (DS) capability for providing reserve services. On the other hand, customers participate in demand response (DR) programs by using load curtailment (LC) and load shifting (LS) options as well as by providing reserve service to minimize their consumption costs. The proposed model is implemented on a test VPP and the optimal decisions are investigated in detail through a numerical study. Numerical simulations demonstrate the effectiveness of the proposed scheduling strategy and its operational advantages and the computational effectiveness.

**Index Terms**—Demand response (DR), energy and reserve scheduling, virtual power plant (VPP), renewable generation.

## NOMENCLATURE

### Indices and sets

$t (N_T)$	Time intervals.
$s (N_S)$	Scenarios.
$i (N_G)$	DGs.
$j (N_J)$	Load groups.
$w (N_W)$	Wind turbines.
$k (N_K)$	ESS.
$(\cdot)_{t,s}$	At time $t$ in scenario $s$ .
$\underline{(\cdot)}, \overline{(\cdot)}$	Min/max value of parameter $(\cdot)$

The work of M. Shafie-khah was supported by FLEXIMAR-Project (Novel Marketplace for Energy Flexibility), which has received funding from Business Finland Smart Energy Program, 2017-2021. The work of J.P.S. Catalão was supported in part by FEDER funds through COMPETE 2020 and in part by the Portuguese funds through FCT, under POCI-010145-FEDER029803 (02/SAICT/2017). (*Corresponding authors: M. Shafie-khah; J.P.S. Catalão*).

M. Vahedipour-Dahraie and H. Rashidizadeh-Kermani are with the University of Birjand, Birjand 9717434765, Iran (e-mails: vahedipour\_m@birjand.ac.ir; rashidi\_homa@birjand.ac.ir).

M. Shafie-khah is with the School of Technology and Innovations, University of Vaasa, 65200 Vaasa, Finland (e-mail: mshafiek@univaasa.fi).

J.P.S. Catalão is with the Faculty of Engineering of the University of Porto, 4200-465 Porto, Portugal, and also with INESC TEC, 4200-465 Porto, Portugal (e-mail: catalao@fe.up.pt).

### Parameters and constants

$\beta$	Weighting parameter for risk aversion.
$\alpha$	Confidence level of VPP.
$G^l (B^l)$	Conductance (Susceptance) of line $l$ .
$D_{j,t}$	Demand of customer $j$ at time $t$ (MW).
$D_{j,t}^{int}$	Initial value of demand of load $j$ at time $t$ (MW)
$\rho_{j,t}$	Electricity price offered to load $j$ at time $t$ (\$/MWh).
$\rho_{j,t}^{int}$	Initial value of electricity price offered to load $j$ at time $t$ (\$/MWh).
$S(D_{j,t}^{end})$	Benefit of load $j$ after applying DR program (\$).
$B(D_{j,t}^{end})$	Income of load $j$ after applying DR program (\$).
$\eta_k^{ch}, \eta_k^{dch}$	Charging loss and discharge leakage loss factors of ESS $k$ .
$\rho_{i,t}^{Up} (\rho_{i,t}^{Dn})$	Bid of up (down)-spinning (\$/MWh).
$\rho_{j,t}^{Up} (\rho_{j,t}^{Dn})$	Bid of up (down)-spinning reserve (\$/MWh).
$\rho_t^{DAbuy}$	Day-ahead buying (selling) electricity price (\$/MWh).
$(\rho_t^{DA sell})$	
$\rho_{i,t}^{Non}$	Bid of non-spinning reserve (\$/MWh).
$\rho_{j,t}^{Voll}$	Value of lost load (\$/MWh).
$\pi_s$	Occurrence probability of scenario $s$ .
$\lambda_j$	Potential of DR programs implemented by customer $j$ .
$CU_i (CD_i)$	Start-up (Shut-down) cost of DG unit $i$ (\$).

### Variables

$p$	Active power (MW).
$P_{t,s}^{DA}$	Active power traded between the VPP and the main grid in the DA market (MW).
$P_{t,s}^{Buy} (P_{t,s}^{Sell})$	Total active power bought/sold by the VPP (MW).
$q$	Reactive power (MVar).

$q_{t,s}^{DA}$	Reactive power traded between the VPP and the main grid in the DA market (MVar).
$q_{t,s}^{Buy} (q_{t,s}^{Sell})$	Total reactive power absorbed/injected to main grid by VPP (MVar).
$p_{j,t,s}^{shed} (q_{j,t,s}^{shed})$	Active (reactive) power of load shedding of customer $j$ (MW).
$R_i^{Up} (R_i^{Dn})$	Up (down) spinning reserve provided by DG $i$ (MW).
$R_j^{Up} (R_j^{Dn})$	Up (down) spinning reserve provided by customer $j$ (MW).
$R_i^{Non}$	Non-spinning reserve provided by DG unit $i$ (MW).
$r_{i,t,s}^{Up} (r_{i,t,s}^{Dn})$	Up (down) reserve deployed by DG $i$ (MW).
$r_{j,t,s}^{Up} (r_{j,t,s}^{Dn})$	Up (down) reserve deployed by customer $j$ (MW).
$p_{t,s}^{shed} (q_{t,s}^{shed})$	Active (reactive) power of load shedding (MW).
$P_{LR}$	The amount of load reduction (MW).
$p_k^{ch,ESS}$	Charging power of ESS $k$ (MW)
$p_k^{dis,ESS}$	Discharging power of ESS $k$ (MW)
$E_{k,t}^{ESS}$	Energy capacity of ESS unit $k$ (MWh)
$\eta_s, \zeta$	Auxiliary variable and value-at-risk for calculating the CVaR (\$).
$u_{i,t,s}$	Commitment status of DG unit $i$ , $\{0, 1\}$ .
$y_{i,t,s} (z_{i,t,s})$	Start-up (shut-down) indicator of DG $i$ , $\{0, 1\}$ .
$\vartheta_{k,t,s}$	Binary variable denoting the charge and discharge status of ESS $k$ .
$\sigma_{t,s}$	Binary variable denoting VPP total power exchanging, 1 for buying power and 0 for selling power.

## I. INTRODUCTION

### A. Motivation

A virtual power plant (VPP) collects the capacity of several distributed energy resources (DERs), energy storage systems (ESSs) and different types of customers and acts as an agent in the retail market [1]. A VPP plays an efficient role in the successful coupling of renewable generation with demand-side (DS) management and participate in wholesale markets or to provide system support services [2].

Participating in electricity markets considering uncertainties related to the renewable energy resources (RESs), load forecast errors, and market prices, introduce risk on the decision-making strategy of the VPP [3]. In the energy internet environment, DS resources mainly participate in the power system with the form of demand response (DR) program to shift or reshape the load profile to mitigate the challenges posed by uncertain resources such as renewable energy generation [4]. DS resources can provide ancillary services for smart grids and improve their flexibility and economy, effectively [5].

### B. Background and Related Works

In the literature, there exist several research works investigating the energy management strategies considering DS resources and uncertainties. In [6], a decentralized energy trading framework has been presented for independent system operators (ISOs) to incentivize the entities toward an operating point that jointly optimize the cost of load aggregators and profit of the generators, as well as the risk of shortage in the renewable generation. Moreover, a same approach has been presented in [7], in which each individual entity responds to the control signals called conjectured prices from the ISO to modify its demand or generation profile with the locally available information. In [8], an energy management strategy has been presented for a VPP including various DERs and DR participants in which uncertainties of electricity prices and renewable generations have been well characterized, but the risks of uncertainties in optimization problem have not been addressed.

Moreover, in [9], a mathematical model has been projected for optimal scheduling of a VPP participating in day-ahead market (DAM) and intraday DR exchange market. In that study, the uncertainty of RESs' output power, electricity prices and customers' demand have been addressed, but the risks of the uncertainties on VPP's decisions have not been investigated. For instance, a risk-constrained stochastic programming problem has been offered in [10] for energy scheduling of a VPP. The conditional value at risk (CVaR) tool is also added to the formulation to control the risk of low profit scenarios. In the same manner, in [11] a stochastic bi-level problem has been proposed to investigate optimal scheduling of a VPP.

In the literature, there are a few works tackling the joint energy and reserve scheduling of VPP. In [12], a stochastic adaptive robust optimization (ARO) approach has been presented for the self-scheduling of a VPP in both the DAM and the SRM. The proposed model explicitly accounts for the uncertainty associated with the VPP being called upon by the ISO to deploy reserves. In [13], a risk aversion stochastic strategy has been presented for energy and reserve scheduling of a VPP with minimum CVaR objective considering maximum operation revenue. In that strategy the uncertainties of some parameters such as price markets and calls for reserve services that have more effect on the optimization results, are not considered in the model. In [14], a multi-time-scale economic scheduling strategy has been presented for VPP to participate the wholesale DAM and the SRM considering deferrable loads aggregation and disaggregation. Also, a risk-averse optimal offering model has been presented in [15] for scheduling joint energy and reserve service in a VPP, in which CVaR has been used. In [16], an optimal offering strategy has been presented for VPP decision making problem, where the VPP participates in the DAM, the real-time market (RTM) and the SRM.

In [17], an arbitrage strategy has been presented for VPPs by participating in the DAM and the SRM with goal of maximizing VPP's profit considering arbitrage opportunities. In that work, VPP participates in a joint market of energy and reserve services by addressing DS management, but the uncertainties of RESs generation and DR are not considered.

In [18], a DA scheduling framework has been developed for VPP participating in the both the DAM and the SRM. Different stochastic parameters with regard to wind production, loads demand, the DAM and the SRM prices are taking into account using a point estimate method. Moreover, a robust optimization problem has been presented in [19] for VPP scheduling bearing in mind the uncertainty of renewables and DS resources. In that study, a bi-level optimization problem with a double robust coefficient for renewable power providers has been formulated.

### C. Summary of Main Contributions

A primary objective of this study is to develop a risk-averse stochastic programming framework to optimal scheduling of energy and reserve services for a VPP considering DR programs while taking into account different types of uncertainty. A two-stage risk-averse stochastic framework is proposed, where the uncertainty of the DA and RT prices, renewable output power, DS resources as well as the uncertainty in the call for reserve services are considered. Also, CVaR is employed in the stochastic model to manage the energy and reserve capacity and to control the risk of VPP profit variability. Furthermore, the effects of the risk factor on CVaR and VPP profit are studied, and the economic paybacks of the proposed scheme under different price-based DR actions are discussed. In this work, the economic benefits of different DR actions including load curtailment (LC), load shifting (LS) and LC&LS options in providing spinning reserve services in the VPP are evaluated through a comparative study.

VPP operation strategies based on DS management have received intensive attentions in recent works. The comparisons with existing literatures are summarized in TABLE I, where “O” and “-” respectively indicate whether a particular aspect is considered or not. At the time of decision making problem in the DAM and the SRM, the VPP confronts with different uncertainties, namely, RESs productions, market prices, demand loads and call for reserve services. Neglecting each of these uncertainties may significantly affect the accuracy of the decision making problems of the VPP. In the stochastic programming approach presented in the aforementioned works have not been comprehensively considered the system topology [8]-[18], the some of the uncertainties (i.e., call for reserve services) in the mathematical model [15]-[19], and decision making of the VPP in the DAM, RTM and the SRM, simultaneously [6]-[13].

Therefore, the main contributions of this paper are summarized as follows:

- A two-stage risk-averse stochastic programming problem is proposed for joint energy and reserve scheduling of a VPP taking different types of price-based DR programs into account. All uncertain parameters including RESs output power, DAM, RTM and SRM prices, as well as DR participation and calls for reserve service are taken into account in the model.
- Utilization of ESS units is augmented for offsetting the deviation between required and actual balancing powers at a given confidence level, and the multi-period coupling effect of ESS is taken into consideration.

TABLE I  
COMPARISONS OF THE VPP SCHEDULING STRATEGY WITH EXISTING LITERATURE.

References	[6], [7]	[8], [9]	[10],	[11]	[12]	[13]	[14]	[15], [16]	[17]	[18]	[19]	This paper
Under-study agent	ISO	VPP	VPP	VPP	VPP	VPP	VPP	VPP	VPP	VPP	VPP	VPP
Trading floors	DAM + RTM	DAM + RTM	DAM + RTM	DAM + RTM	DAM + SRM	DAM + SRM	DAM+ RTM+ SRM	DAM+ RTM+ SRM	DAM+ RTM+ SRM	DAM+ RTM+ SRM	DAM+ RTM+ SRM	DAM+ RTM+ SRM
DS management	✓	✓	✓	✓	✓	✓	✓	✓	✓	✓	✓	✓
Network topology	✓	-	-	-	-	-	-	-	-	-	-	✓
Network constraints	✓	-	-	-	-	-	-	-	-	-	✓	✓
Consideration of reactive power	-	-	-	-	-	-	-	-	-	-	✓	✓
Reserve scheduling	-	-	-	-	-	✓	-	✓	✓	✓	✓	✓
System uncertainty	RESs power	✓	✓	✓	✓	✓	✓	✓	✓	✓	✓	✓
	Market prices	-	✓	-	-	✓	✓	✓	✓	✓	✓	✓
	Calls for reserve	-	-	-	-	✓	-	✓	✓	-	-	✓
	Demand	✓	✓	✓	-	✓	✓	✓	✓	✓	✓	✓
Uncertainty handling	SPA*	SPA	IA	RHA	ARO	SPA	SPA	SPA	SPA	ROA	ROA	SPA
Risk measure	CVaR	-	-	-	CVaR	CVaR	CVaR	-	CVaR	-	-	CVaR

\* SP: stochastic programming approach, IA: interval analysis approach, RHA: rolling horizon approach, ROA: robust optimization approach, SR: spinning reserve, ARO: adaptive robust optimization.

- The applicability of price based-DR programs is upgraded to be applicable for different electric devices of a residential home as LC, LS and LC&LS actions on the economic and security indices of the VPP.

#### D. Organization

The rest of the paper is organized as follows. In Section II, the proposed scheduling strategy is described. In Section III, the mathematical model of the problem is provided. In Section IV, the proposed framework is implemented to a case study and the simulation results are discussed. Finally, the conclusions are given in Section V.

### II. PROBLEM DESCRIPTION AND ASSUMPTIONS

This paper considers a VPP within a smart structure, which consists of the integration of DERs, i.e. dispatchable DG units, wind power generators, conventional storage facilities as well as responsive loads. The VPP operator schedules energy and reserve resources jointly to provide its local loads, as well as tries to maximize its profit by exchanging energy in both DAM and RTM. In other words, the VPP operator makes decisions on trading energy with the wholesale market based on information such as DS decisions, energy and reserve prices and RESs productions.

Active participation of customers in DR programs can have a significant effect on the operator's decisions. Each customer has a number of responsive loads including shiftable and sheddable loads and some non-responsive loads [20]. Here, it is supposed that customers are able to take part in price-based DR programs by managing consumption of their smart household appliances to reduce electricity bills.

The detailed information of the proposed scheduling strategy for the VPP is presented in Fig. 1. As shown, different stochastic and deterministic parameters are used as input data of the proposed optimization problem. Prior to solving the problem, the uncertainties of stochastic parameters are modeled as stochastic processes, where Monte-Carlo simulation (MCS) method [21] is applied for scenario generation. In this work, uncertainties of renewable power, loads demand, DAM, RTM and SRM prices as well as uncertainties of calls for reserve service are considered. After generating scenario for each parameter, the sets of generated scenarios are combined to build a scenario tree. Since the number of generated scenarios directly affects the computation complexity of optimization problem, it is needed to be reduced into a smaller number of scenarios representing well enough the uncertainties. To reduce the computational burden of the stochastic procedure, K-means algorithm [22] as a proper scenario-reduction technique is used to reduce scenario tree to an appropriately small number of scenarios. In the next step, these scenarios are used to the stochastic scheduling problem.

In the proposed strategy, the scheduling is performed in two stages, which in the first stage the VPP submits the hourly bidding decision of energy and reserve in the DAM and SRM for the next day. In this stage, decisions are made before knowing the future market prices, load demand and RES power generations. This means that these decisions are made with non-anticipatively with respect to the considered scenarios. The variables in this stage optimize the utilization scheduling problem before the realization of the uncertainties.

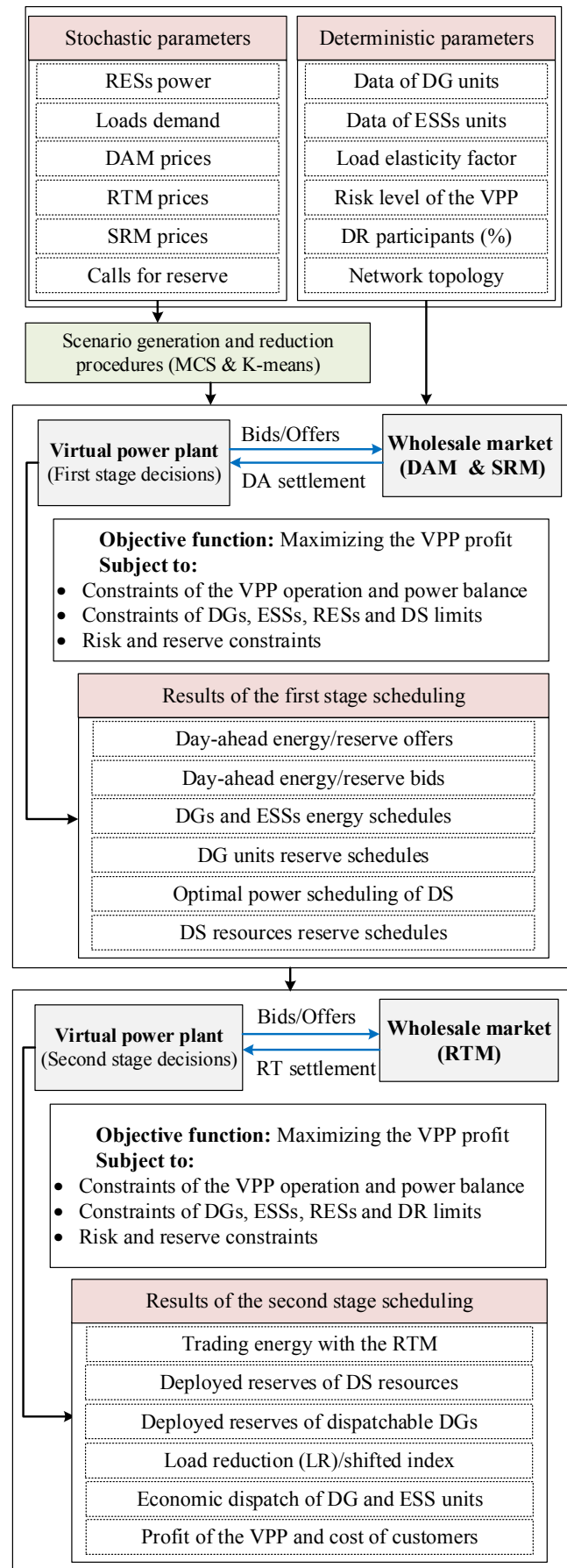

Fig. 1. The structure of the proposed scheduling strategy.

In the second stage, the VPP decides the RT energy and reserve exchanging with the RTM and make RT dispatching decisions for DGs, ESSs and DS resources in each time period. Decisions of this stage, that are made after the realization of scenarios, include state of DGs, optimal output power of DGs, load after implementing DR programs, deployed reserve of DGs and DS resources, and curtailed loss of load.

Due to the existence of the random variables, the VPP decision making strategy has risky conditions. In this regard, CVaR is employed as a risk measurement in the management of the optimization problem to capture the risk aversion behavior of the VPP operator in different conditions. The resulting two-stage optimization model is expressed as a mixed-integer linear programming (MILP) problem [23].

### III. MATHEMATICAL FORMULATION OF PROPOSED STOCHASTIC PROGRAMMING MODEL

#### A. Model of responsive loads

The objective of consumers is to maximize their benefits, the payoffs from the VPP minus dissatisfaction costs due to the change of their energy usage.

Based on the proposed model, customers participate in DR programs with sheddable and shiftable loads by applying LC and LS options.

The concepts of self-elasticity ( $E_{t,t}^j$ ) and cross-elasticity ( $E_{t,h}^j$ ) are respectively employed to model the sensitivity of sheddable loads and shiftable loads with respect to the prices.  $E_{t,t}^j$  and  $E_{t,h}^j$  are defined as sensitivity of demand at time  $t$  with respect to price at time  $t$  and  $h$ , and represented as (1) and (2), respectively [20]:

$$E_{t,t}^j = \frac{\rho_{j,t}^{\text{int}}}{D_{j,t}^{\text{int}}} \cdot \frac{\Delta D_{j,t}}{\Delta \rho_{j,t}} \quad (1)$$

$$E_{t,h}^j = \frac{\rho_{j,h}^{\text{int}}}{D_{j,t}^{\text{int}}} \cdot \frac{\Delta D_{j,t}}{\Delta \rho_{j,h}} \quad (2)$$

When customer  $j$  participates in the price-based DR program, it changes its responsive loads from  $D_{j,t}^{\text{int}}$  (initial value) to  $D_{j,t}^{\text{end}}$  to achieve the maximum benefit.

$$D_{j,t}^{\text{end}} = D_{j,t}^{\text{int}} + \Delta D_{j,t} \quad (3)$$

The benefit of customer  $j$  can be obtained as:

$$S(D_{j,t}^{\text{end}}) = B(D_{j,t}^{\text{end}}) - D_{j,t}^{\text{end}} \rho_{j,t} \quad (4)$$

To maximize the customer's utility function, (5) needs to be verified [20]:

$$\partial S(D_{j,t}) / \partial D_{j,t} = 0 \Rightarrow \partial B(D_{j,t}) / \partial D_{j,t} = \rho_{j,t} \quad (5)$$

Taking the linear relationship among hourly load and electricity prices into account, when customer  $j$  participate in DR only with LC option, its utility is given as [20]:

$$B(D_{DR}(t)) = B(D_{j,t}^{\text{int}}) + \rho_{j,t}^{\text{int}} [D_{j,t} - D_{j,t}^{\text{int}} (1 + \frac{D_{j,t} - D_{j,t}^{\text{int}}}{2E_{t,t}^j D_{j,t}^{\text{int}}})] \quad (6)$$

Differentiating (6) with respect to  $D_{j,t}$  and substituting the result in (5) denotes:

$$D_{j,t}^{\text{end}} = D_{j,t}^{\text{int}} [1 + E_{t,t}^j \frac{\rho_{j,t} - \rho_{j,t}^{\text{int}}}{\rho_{j,t}^{\text{int}}}] \quad (7)$$

Also, the utility of customer  $j$  when participating in DR only with LS option can be stated as:

$$D_{j,t}^{\text{end}} = D_{j,t}^{\text{int}} [1 + \sum_{\substack{h \in T \\ h \neq t}} E_{t,h}^j \frac{\rho_{j,h} - \rho_{j,h}^{\text{int}}}{\rho_{j,h}^{\text{int}}}] \quad (8)$$

Therefore, the economic model of demand of customer  $j$  when participating in DR program with both LC and LS options can be expressed with combining (7) and (8) as follows:

$$D_{j,t}^{\text{end}} = (1 - \lambda_j) \times D_{j,t}^{\text{int}} + \lambda_j \times D_{j,t}^{\text{int}} \left[ 1 + \sum_{h=1}^{N_T} E_{t,h}^j \frac{\rho_{j,h} - \rho_{j,h}^{\text{int}}}{\rho_{j,h}^{\text{int}}} \right] \quad (9)$$

#### B. Mathematical descriptions of uncertainties

The VPP faces operation uncertainties including RESs production, the DAM, the RTM and the SRM prices, load and calls for reserve service. In this study, prediction errors of random variables of the VPP are modeled by their related probability density functions (PDFs). Related PDFs are calculated based on previous records of the mentioned parameters for the examined environment. Here, the forecasted errors of load demand and prices of the different markets are modeled using a normal distribution that their PDFs can be expressed as [24]:

$$f(x) = \frac{1}{\delta \sqrt{2\pi}} \exp \frac{-(x - \mu)}{2\delta^2} \quad (10)$$

where  $x$  refers to uncertain parameter,  $\delta$  standard deviation parameter and  $\mu$  is the mean values of the uncertain parameter that is equivalent to the forecasted values of related variable. In this study, the normal PDFs at each hour are divided into seven discrete intervals with different probability levels as shown in Fig. 2.

Moreover, the Weibull distribution is used to model the wind speed uncertainty as follows [25].

$$f(x) = \frac{\varphi}{\zeta} \left(\frac{x}{\zeta}\right)^{\varphi-1} \exp\left[-\left(\frac{x}{\zeta}\right)^\varphi\right] \quad (11)$$

where  $v$ ,  $\varphi$  and  $\zeta$  are wind speed, shape and scale parameters, respectively.

Uncertainty of calls for reserve represents that the actual reserve deployed by responsive loads deviates from the amount of reserve that VPP calls. Considering response ratio  $\kappa_{j,t}$  as the ratio between the realized deployed reserve and estimated reserve of customer  $j$ , can be written:

$$\kappa_{j,t} = \frac{r_{j,t}^{\text{act}}}{r_{j,t}} \quad (12)$$

where  $\kappa_{j,t}$  is a random variable obeying normal PDF i.e.,  $N(\mu_{j,t}, \delta_{j,t}^2)$  that  $\mu_{j,t}$  and  $\delta_{j,t}^2$  are the expectation and the standard deviation of variable  $\kappa_{j,t}$ .

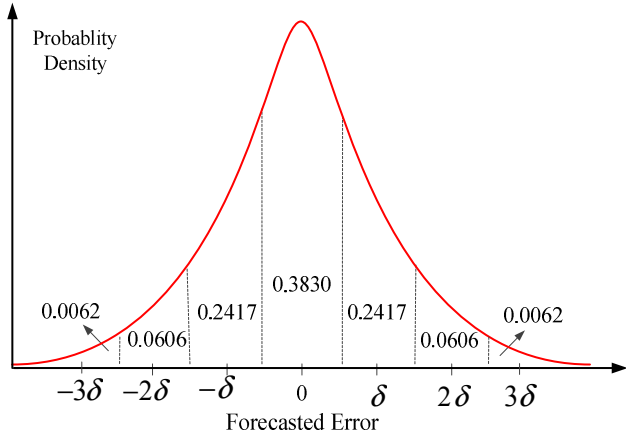

Fig. 2. Typical discretization of the probability density of forecasted errors of a stochastic parameter.

In this study, MCS method is applied for scenario generation based on random sampling from distribution functions of each stochastic parameter. At first, for each mentioned random variable, number of 100 scenarios is generated, and the generated scenarios are combined and the scenario tree with  $10^{12}$  scenarios is obtained that yields an intractable optimization problem. To unravel the problem with this large number of scenarios, K-means classification method is employed to reduce the number of scenarios to 200 to decrease the computation burden.

### C. Objective Function

The objective function of the problem is maximization of the VPP's profit including terms of profit associated with here-and-now and wait-and-see decisions and also the term of CVaR tool. Therefore, it can be formulated as:

$$\text{Maximize } EP = [P^{H\&N} + P^{W\&S} + \beta \times CVaR] \quad (13)$$

where,  $P^{H\&N} = \psi_1 - \psi_2 - \psi_3$ , which  $\psi_1$  to  $\psi_3$  can be captured by the following equations:

$$\begin{aligned} \psi_1 = & \sum_{t=1}^{N_T} \sum_{s=1}^{N_S} \pi_s P_{t,s}^{DA,sell} \rho_{t,s}^{DA,sell} + \sum_{t=1}^{N_T} \sum_{j=1}^{N_J} \sum_{s=1}^{N_S} \pi_s (D_{j,t,s}^{end} - p_{j,t,s}^{shed}) \rho_{j,t} \\ & + \sum_{t=1}^{N_T} \sum_{i=1}^{N_G} \sum_{s=1}^{N_S} \pi_s (\rho_{m,t,s}^{Up,sell} R_{m,t}^{Up,sell} + \rho_{m,t,s}^{Dn,sell} R_{m,t}^{Dn,sell}) \end{aligned} \quad (14)$$

$$\psi_2 = \sum_{t=1}^{N_T} \sum_{i=1}^{N_G} \sum_{s=1}^{N_S} \pi_s \begin{bmatrix} (a_i u_{i,t,s} + b_i P_{i,t,s}) \\ + SUC_i y_{i,t,s} + SDC_i z_{i,t,s} \\ + \rho_{i,t,s}^{Up} R_{i,t}^{Up} + \rho_{i,t,s}^{Dn} R_{i,t}^{Dn} + \rho_{i,t,s}^{Non} R_{i,t}^{Non} \end{bmatrix} \quad (15)$$

$$\begin{aligned} \psi_3 = & \sum_{t=1}^{N_T} \sum_{j=1}^{N_J} \sum_{s=1}^{N_S} \pi_s (\rho_{j,t,s}^{Dn} R_{j,t}^{Dn} + \rho_{j,t,s}^{Up} R_{j,t}^{Up}) \\ & + \sum_{t=1}^{N_T} \sum_{i=1}^{N_G} \sum_{s=1}^{N_S} \pi_s (\rho_{m,t,s}^{Up,buy} R_{m,t}^{Up,buy} + \rho_{m,t,s}^{Dn,buy} R_{m,t}^{Dn,buy}) \end{aligned} \quad (16)$$

where, the first term of  $\psi_1$  denotes the revenue of energy trading between the VPP and the main grid in DA market and selling energy to customers. Also, the second term of  $\psi_1$  denotes the revenue of providing reserve services for the grid.

Moreover,  $\psi_2$  represents start-up and shut-down costs of DG units and their operating cost, and  $\psi_3$  is the costs of reserve capacity provided by DR and the main grid.

$$EP^{W\&S} = \sum_{s=1}^{N_S} \pi_s (-\varphi_{s,1} - \varphi_{s,2}) \quad (17)$$

$$\begin{aligned} \varphi_{s,1} = & \sum_{s=1}^{N_S} \sum_{t=1}^{N_T} \sum_{i=1}^{N_G} \pi_s \rho_{i,t}^{dep} (r_{i,t,s}^{Up} + r_{i,t,s}^{Dn} + r_{i,t,s}^{Non}) \\ & + \sum_{s=1}^{N_S} \sum_{t=1}^{N_T} \sum_{j=1}^{N_J} \pi_s \rho_{j,t}^{dep} (r_{j,t,s}^{Up} + r_{j,t,s}^{Dn}) \\ & + \sum_{t=1}^{N_T} \sum_{s=1}^{N_S} \sum_{k=1}^{N_K} \pi_s (\rho_{k,t}^{ESS} P_{k,t,s}^{ch,ESS} + \rho_{k,t}^{ESS} E_{k,t,s}^{ESS} \eta_k^{dis}) \end{aligned} \quad (18)$$

$$\varphi_{s,2} = \sum_{t=1}^{N_T} \sum_{s=1}^{N_S} \sum_{j=1}^{N_J} \pi_s \rho_{j,t}^{voll} (p_{j,t,s}^{shed}) \quad (19)$$

Term  $\varphi_{s,1}$  stands for cost of deployed reserve of DGs and DR as well as operational cost of BESSs that refers to their lifecycle costs. Moreover,  $\varphi_{s,2}$  represents the cost of mandatory load shedding in the scheduling horizon.

Furthermore, term of CVaR is calculated as follows [26]:

$$CVaR = \zeta + (1 - \alpha)^{-1} \times \sum_{s=1}^{N_S} \pi_s \eta_s \quad (20)$$

The CVaR multiplied by the weighting parameter  $\beta$  is used in the model, in which  $\beta$  models the tradeoff amongst the VPP's profit and the risk of profit variability. A risk-averse operator selects a large value of  $\beta$  to increment risk weight and a risk-neutral operator prefers higher risk to obtain higher profit, thereby it assigns the value of  $\beta$  close to zero [26].

### D. The Problem Constraints

The power balance constraints ensure that the buying power from the main grid plus the power produced by the VPP's local generation units can provide demand of the customers. Therefore, active and reactive power balance constraints at node  $n$  can be written as follows:

$$p_{t,s}^{DA} + p_{i,t,s}^n + p_{w,t,s}^n - D_{j,t,s}^n + p_{j,t,s}^{n,shed} = \sum_{r=1}^{N_B} f_{(n,r),t,s}^P \quad (21)$$

$$q_{t,s}^{DA} + q_{i,t,s}^n + q_{w,t,s}^n - q_{j,t,s}^n + q_{j,t,s}^{n,shed} = \sum_{r=1}^{N_B} f_{(n,r),t,s}^Q \quad (22)$$

$$\begin{aligned} f_{(n,r),t,s}^P = & G_{n,r} (V_{n,t,s} - V_{r,t,s} - \omega_{n,r,t,s} + 1) \\ & - B_{n,r} (\delta_{n,t,s} - \delta_{r,t,s}) \end{aligned} \quad (23)$$

$$\begin{aligned} f_{(n,r),t,s}^Q = & -B_{n,r} (V_{n,t,s} - V_{r,t,s} + \omega_{n,r,t,s} + 1) \\ & - G_{n,r} (\delta_{n,t,s} - \delta_{r,t,s}) \end{aligned} \quad (24)$$

where,  $p_{t,s}^{DA} = p_{t,s}^{DA,buy} - p_{t,s}^{DA,sell}$ ,  $q_{t,s}^{DA} = q_{t,s}^{DA,buy} - q_{t,s}^{DA,sell}$  and,  $p_{(n,r),t,s}$  and  $q_{(n,r),t,s}$  are the active and reactive power flowing between bus  $n$  and  $r$ .



The constraints related to the operation of DGs are related to start-up cost limits (25), shut down cost limits (26), power capacity limits (27) and ramping up/down limits (28)-(29), [20].

$$SUC_{i,t} \geq CU_i(u_{i,t,s} - u_{i,t-1,s}) \quad (25)$$

$$SDC_{i,t} \geq CD_i(u_{i,t-1,s} - u_{i,t,s}) \quad (26)$$

$$\underline{P}_i u_{i,t,s} \leq p_{i,t,s} \leq \overline{P}_i u_{i,t,s} \quad (27)$$

$$p_{i,t,s} - p_{i,t-1,s} \leq RU_i(1 - y_{i,t,s}) + \underline{P}_i y_{i,t,s} \quad (28)$$

$$p_{i,t-1,s} - p_{i,t,s} \leq RD_i(1 - z_{i,t,s}) + \underline{P}_i z_{i,t,s} \quad (29)$$

Also, the min-up and down times of DGs should be satisfied. Also, the charge and discharge process of the ESS is modeled as follows [27]:

$$0 \leq p_{k,t,s}^{ch,ESS} \leq (1 - \vartheta_{k,t,s}) \times \overline{P}_{k,t}^{ch,ESS} \quad (30)$$

$$0 \leq p_{k,t,s}^{dis,ESS} \leq \vartheta_{k,t,s} \times \overline{P}_{k,t}^{ch,ESS} \quad (31)$$

$$E_{k,t,s}^{ESS} = E_{k,t-1,s}^{ESS} + (\eta_k^{ch} p_{k,t,s}^{ch,ESS} - p_{k,t,s}^{dis,ESS} / \eta_k^{dis}) \times \Delta t \quad (32)$$

$$\underline{E}_{k,t}^{ESS} \leq E_{k,t,s}^{ESS} \leq \overline{E}_{k,t}^{ESS} \quad (33)$$

The limitations of (30) and (31) should be satisfied for charging and discharging power of ESS  $k$ . Also, constraint (32) is considered to model dynamic state of ESS  $k$ , which is limited to the energy capacity of unit  $k$  in (33). The surplus/shortage power of the VPP should be traded with the main grid as its scheduled power in DA market, which are characterized as *sell* and *buy* power. The trading power is limited as follows:

$$-p_{t,s}^{sell} \leq p_{t,s}^{DA} \leq p_{t,s}^{buy} \quad (34)$$

$$0 \leq P_{t,s}^{buy} \leq \overline{P}_t^{buy} \cdot \sigma_{t,s} \quad (35)$$

$$0 \leq p_{t,s}^{sell} \leq \overline{P}_t^{sell} (1 - \sigma_{t,s}) \quad (36)$$

Finally, the reserve up and down services given by DG units and DR are limited by constraints (37)-(41).

$$0 \leq R_{i,t}^{Up} \leq \overline{P}_i u_{i,t} - p_{i,t,s} \quad (37)$$

$$0 \leq R_{i,t}^{Dn} \leq p_{i,t,s} - \underline{P}_i u_{i,t,s} \quad (38)$$

$$0 \leq R_{i,t}^{Non} \leq \overline{P}_i (1 - u_{i,t,s}) \quad (39)$$

$$0 \leq R_{j,t}^{Up} \leq p_{j,t,s}^D - \underline{P}_{j,t} \quad (40)$$

$$0 \leq R_{j,t}^{Dn} \leq \overline{P}_{j,t} - p_{j,t,s} \quad (41)$$

#### IV. CASE STUDY

##### A. Test Case and Assumptions

To demonstrate the proposed scheduling, the 15-bus VPP test system illustrated in Fig. 3 has been employed. This system comprises of three dispatchable DG units, four wind turbines, three ESS and 13 load buses. Details about the under-study VPP are given in [27].

The forecasted values of total demand, output power of wind turbines as well as DA electricity prices are considered as depicted in Fig. 3, [28]. The load profile is formed by collecting the electricity load of 2000 residential customers.

The sheddable and shiftable loads of customers are shown in Tables II and III, respectively, [20], [29].

Devices A include electrical equipment up to 200W and devices B include residential devices such as air conditioning systems, fans, hairdryers, coolers, computers, hoods, and other electrical devices up to 1000W.

The price elasticity related to the customers' demand is presented in Table IV, which is extracted from [20]. These values of elasticity is considered since, the daily load profile is assumed to be divided into three different periods, namely valley period (00:00–5:00), off-peak periods (5:00–10:00, 16:00–19:00 and 22:00–24:00) and peak periods (11:00–15:00 and 20:00–22:00). Moreover, the expected values of up and down regulation prices are assumed to be 1.1 and 0.9 of DA prices [9]. The price of up and down spinning reserves is considered to be 15% of the DA energy price [30]. Furthermore, data of DG and ESS units are illustrated in Tables V and VI, respectively [10], [27].

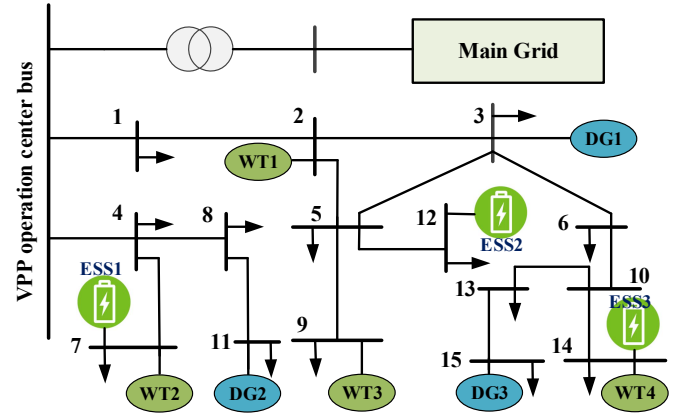

Fig. 3. Single line diagram of 15-bus VPP system.

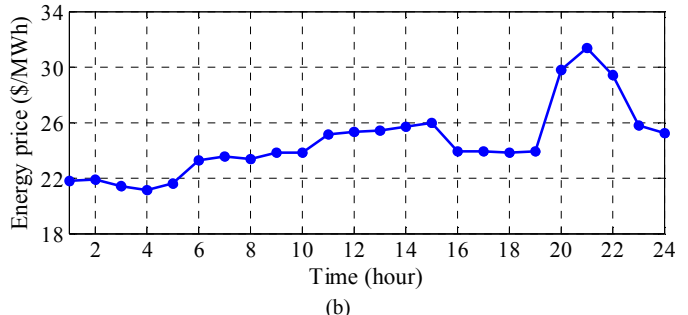
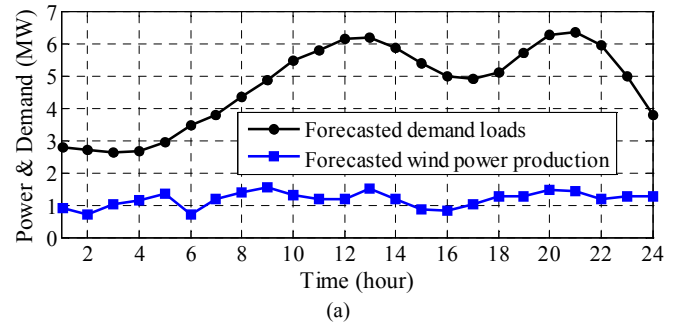

Fig. 4. The forecasted values of (a) wind output power and demand, and (b) DA electricity price.

TABLE II. SHEDDABLE LOADS OF CUSTOMER  $J$  AND THEIR AVERAGE POWER CONSUMPTION.

Time (hour)	Sheddable loads	Power (W)	Time (hour)	Sheddable loads	Power (W)
1-6	Devices A	200	14-16	Devices B	1300
7	Devices B	1300	17-22	Devices B	1550
8-13	Devices B	1550	23-24	Devices B	1300

TABLE III. SHIFTABLE LOADS OF CUSTOMER  $J$  AND THEIR AVERAGE POWER CONSUMPTION.

Type of shiftable load	Average power (W)	Type of shiftable load	Average power (W)
Vacuum cleaners	1200	Dishwashers	2000
Washing machines	2500	Meat grinders	1000
Dryers	1800	Irons	1000

TABLE IV. PRICE ELASTICITY OF LOAD DEMAND

Hour	1-5	6-10	11-15	16-19	20-22	23-24
1-5	-0.08	0.03	0.034	0.03	0.034	0.03
6-10	0.3	-0.11	0.04	0.03	0.04	0.03
11-15	0.034	0.04	-0.19	0.04	0.01	0.04
16-19	0.03	0.03	0.04	-0.11	0.04	0.03
20-22	0.034	0.04	0.01	0.03	-0.19	0.04
23-24	0.03	0.03	0.04	0.03	0.04	-0.11

TABLE V. TECHNICAL DATA OF DG UNITS

DG Unit	$\underline{P}_i$ (MW)	$\bar{P}_i$ (MW)	$a_i$ (\$)	$b_i$ (\$/MWh)	SU Cost (\$)	SD Cost (\$)
DG <sub>1</sub>	0.4	3	20	150	70	20
DG <sub>2</sub>	0.2	1	25	320	70	20
DG <sub>3</sub>	0.1	1.4	35	220	70	20

TABLE VI. TECHNICAL DATA OF ESS UNITS

ESS Unit	$\underline{E}_k^{ESS}$ (kWh)	$\bar{E}_k^{ESS}$ (kWh)	$\eta_k^{ch}, \eta_k^{dis}$	$\bar{P}_{k,t}^{ch,ESS}$ (kW)	$\bar{P}_{k,t}^{dis,ESS}$ (kW)
ESS <sub>1</sub>	40	100	91.4%	50	50
ESS <sub>2</sub>	80	200	91.4%	100	100
ESS <sub>3</sub>	120	300	91.4%	150	150

### B. Results and Discussions

To investigate the impact of DR in different conditions of DS participation in VPP's decisions, the load profile curve characteristics, the trading energy with the main grid, the expected profit and CVaR index is studied in the four following cases:

*Case I:* Without implementing DR program in the VPP,

*Case II:* Customers participate in DR only with LC option,

*Case III:* Customers participate in DR only with LS option,

*Case IV:* Customers partake in DR with both LC and LS options.

The results for the illustrative risk-constrained two-stage stochastic optimization model for the mentioned case studies are obtained using CPLEX under GAMS software [31] on a PC with 4 GB of RAM and Intel Core i7@ 2.60 GHz processor.

Load profiles of VPP in the 4 cases are illustrated in Fig. 5. As observed, in case II, where DR are mainly applied based on LC options, load demand decreases in peak hours in

order to reduce their electricity bills but there is no change in other hours. But in case III, customers decrease their consumption during peak periods and shift a part of it to the other periods, especially to valley periods. Be noted that the daily energy demand before and after the LS actions would remain the same, however by changing the consumption pattern, one could mitigate the energy consumption costs.

Fig. 6 compares the VPP's expected profit and CVaR versus risk-averse parameter  $\beta$  in different cases. It can be observed that the profit of the VPP is reduced by increasing  $\beta$  that is due to occurrence the undesirable outcomes in the worst scenarios in the risk neutral case. However, in case IV in which customers participate in DR program using both of sheddable and shiftable loads, the profit has the highest value while CVaR has its lowest amount. Also, by increasing  $\beta$ , the expected profit of VPP reduces and the CVaR increases in all cases. However, in lower values of  $\beta$  (for the given case study, this level is lower than 1.6), risk aversion has a negligible impact on both profit and CVaR and would not effectively control the losses in expected profits. Instead, in the higher values of  $\beta$ , more profit reduction is observed in all cases that is due to the increasing number of unfavorable scenarios with more negative profits.

Fig. 7 shows energy trade among the VPP and the main grid for all cases in risk-neutral and risk-averse cases. A key observation is that the risk aversion causes decrement of both buying and selling energy trading in the DA market. In the risk-averse case, VPP prefers to supply more demand from its local DG units instead of providing it from the main grid, and so, energy trading in the risk-averse case is lesser than it in the risk-neutral one. In fact, as the VPP behaves more risk aversely, it tends to supply its loads from DG units to eliminate the volatility of market prices.

The hourly scheduled productions of the VPP units including the power of wind turbines, total energy exchanged with the ESS and its energy transaction with the main grid are illustrated in Fig. 8. Here, in order to summarize, only case IV is investigated with and without DR in risk-neutral and risk-averse conditions. Obviously, the total energy exchanging with the main grid decreases in the risk-averse case, however, when responsive loads participate in DR programs, a part of surplus/shortage VPP production is compensated by adjusting energy consumption of responsive loads. Therefore, as shown, the amount of load reduction ( $P_{LR}$ ) is positive in peak-periods, and is negative in off-peak periods. Moreover, the charge and discharge cycles of ESS show that ESS follows an efficient cycle to increase the profit by charging in off-peak and discharging in peak.

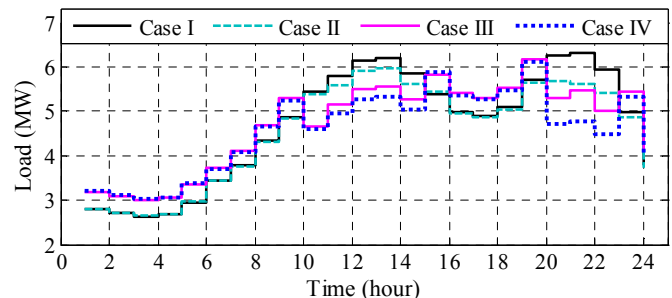

Fig. 5. Load profiles of VPP in different DR actions.



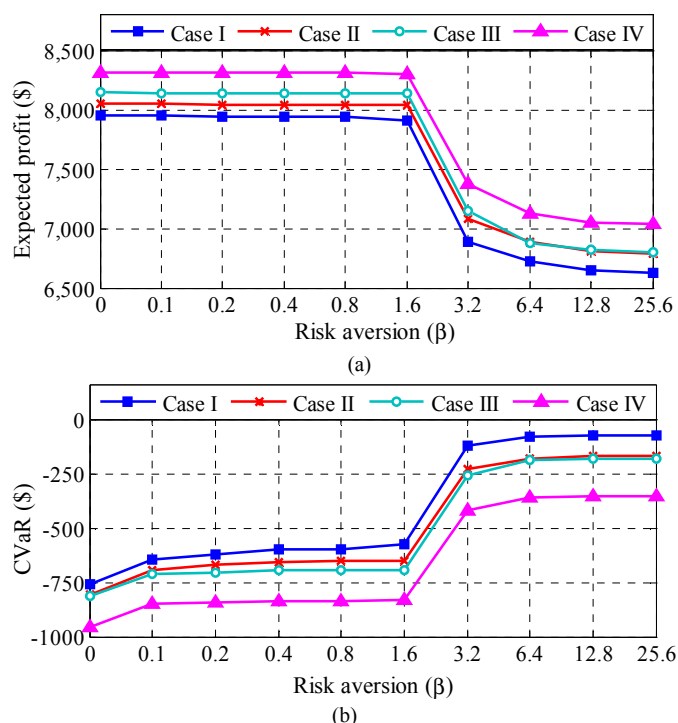

Fig. 6. Expected profit and CVaR in different cases versus factor  $\beta$ , (a) Expected profit, and (b) CVaR.

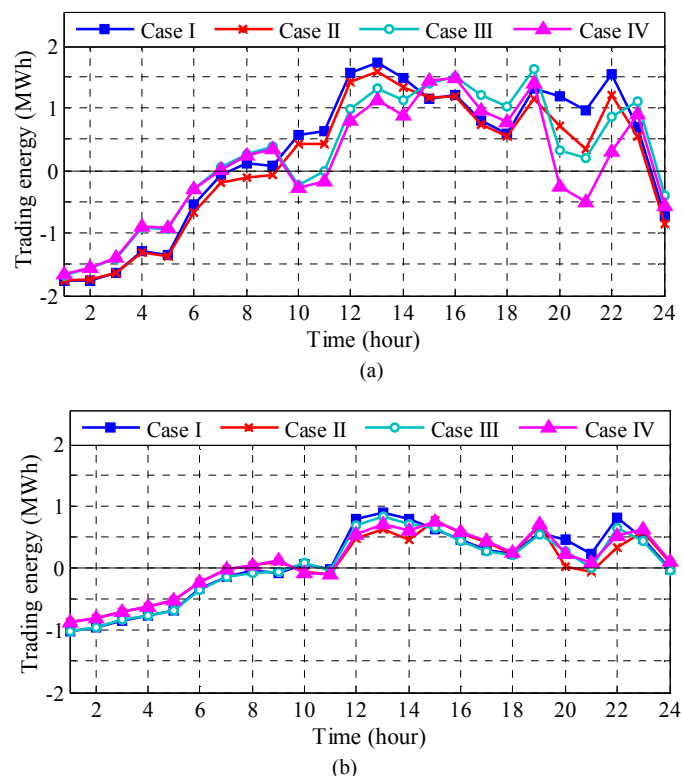

Fig. 7. Energy exchanged among the VPP and the main grid, (a) in the risk-neutral decision (b) in the risk-averse decision.

The total up and down spinning reserves provided by DGs and DS resources in different cases are illustrated in Table VII. The results are represented for four values of  $\beta$  to examine the effect of the risk-aversion on the reserves scheduling of the VPP.

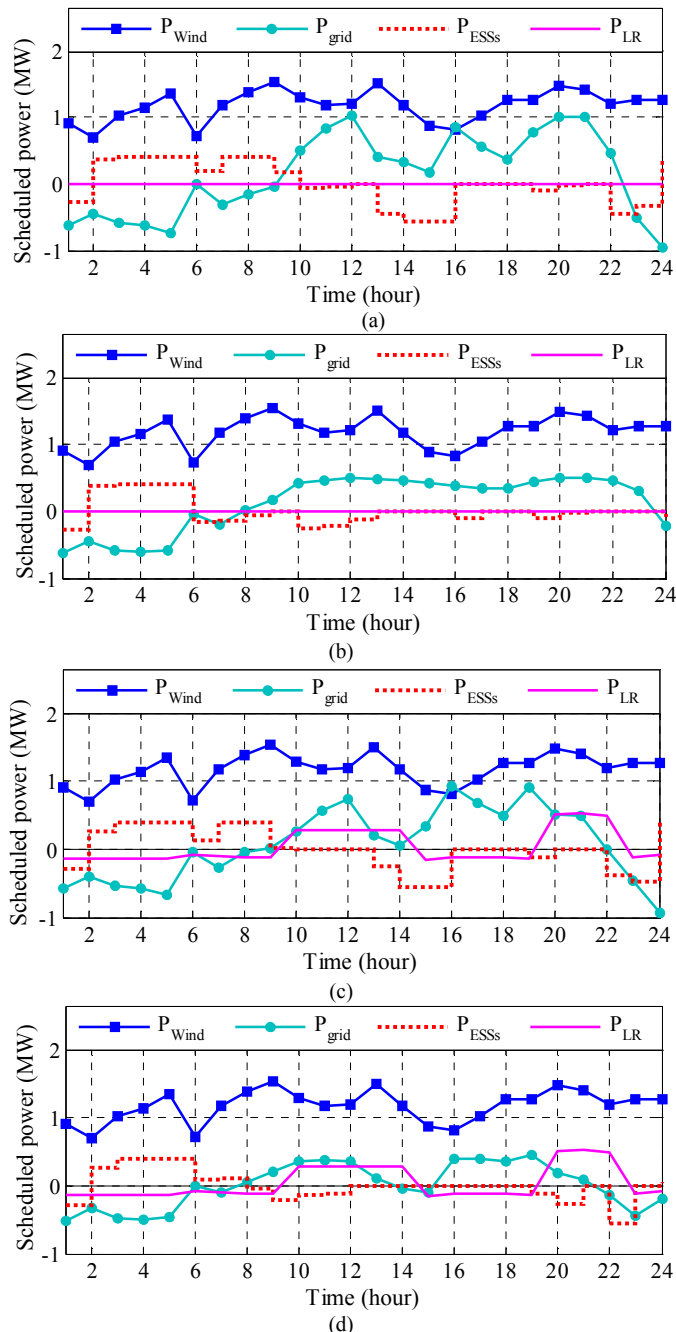

Fig. 8. Hourly power of the VPP's elements, (a) without DR in the risk-neutral decision (b) without DR in the risk-averse decision, (c) with DR in the risk-neutral decision, and (d) with DR in the risk-averse decision.

As it can be seen, participation of DS resources for providing reserve services lead to decrement the contribution of DGs in providing reserves services in all cases.

However, in case IV, that both shiftable and sheddable loads participate in reserve services, contribution of DS to supply reserves is more than that of in the other cases. Moreover, in larger values of  $\beta$ , the whole scheduled reserve is enhanced to diminish the load shedding in unwanted scenarios and guarantee system reliable operation. In fact, by increasing  $\beta$ , the number of worst scenarios decreases and as the result, the uncertain variability of the VPP is accommodated and therefore less reserve services is required.

TABLE VII. TOTAL SCHEDULED RESERVES DURING 24 HOURS OF TIME HORIZON (KW)

Case	$\beta$	Up-spinning reserve of DGs	Down-spinning reserve of DGs	Up-spinning reserve of DS	Down-spinning reserve of DS
Case I	0	11648	12343	0	0
	1.6	10994	10879	0	0
	6.4	9855	10212	0	0
	25.6	8876	9564	0	0
Case II	0	7882	9355	3511	3219
	1.6	7632	9254	3478	3189
	6.4	7548	9177	3409	3120
	25.6	7403	9102	3320	3010
Case III	0	7967	9451	3402	3122
	1.6	6760	4775	3277	2998
	6.4	4596	3566	3122	2893
	25.6	3545	3560	3103	2705
Case IV	0	6648	8208	5572	4953
	1.6	6502	4595	5232	4769
	6.4	4375	3343	5110	4586
	25.6	3031	3101	5005	4421

The computation times of the proposed strategy under various number of scenarios is illustrates in Table VII. The results of this table is obtained for case IV in  $\beta=1.6$ . As it can be seen, when the number of scenarios increases, the problem size increments and therefore the computation time grows. Also, when the number of scenarios increases, the accuracy of the results improves.

TABLE VIII

COMPUTATION TIMES OF THE PROBLEM BASED ON THE ACCURACY OF THE RESULTS UNDER DIFFERENT NUMBER OF SCENARIOS

Number of scenarios	40	80	120	160	200	240
Computation time	282	293	305	318	334	359
Iterations	55743	55932	56202	56721	56965	57255
MIP gap	0	0	0	0	0	0

TABLE IX  
COMPARISON RESULT OF THE PROPOSED STRATEGY AND THE APPROXIMATE MODEL

$\beta$	Proposed model								Approximate model						
	Profit (\$)				Reserve cost (\$)				Computing time (s)				Profit (\$)	Reserve cost (\$)	Computing Time (s)
	Case I	Case II	Case III	Case IV	Case I	Case II	Case III	Case IV	Case I	Case II	Case III	Case IV			
0	7965	8072	8211	8365	4798	4120	4136	4023	343	412	414	423	6218	6788	565
0.2	7960	8069	8202	8360	4532	4043	2934	2835	328	409	411	422	6202	6732	552
0.8	7949	8060	8195	8355	4374	3925	2821	2612	328	407	408	418	6139	6712	550
3.2	6851	7072	7077	7395	4182	3903	2598	2497	312	401	403	412	6093	5983	543
12.8	6729	6803	6802	7055	3881	3853	2322	2235	309	389	398	409	6035	5949	538
25.6	6622	6772	6773	7018	3845	3830	2202	2169	304	381	393	405	6013	5931	533

In order to more investigation of the proposed strategy from the aspect of computation efficiency and economic indices, the results in different cases are compared to a stochastic model wherein, as done in [14], where reserve provision of DS resources is neglected. Such a model, hereinafter referred to as the approximate model, is a modified version of our robust counterpart wherein the proposed formulation for the operation of dispatchable units is replaced with that presented in [14]. Table IX presenters the expected profit of the VPP, the total reserve cost, and the computing times corresponding to the optimal solutions to both the proposed and the approximate models in different risk-averse. As for the computational effort, the computing times in the proposed strategy is less that the approximate model in all conditions. As shown, when DS resources are considered for SR service provision, the total cost of reserve decreases, especially in Case IV, in which customers participate in both of LC and LS options. Moreover, DR participants in SR service lead to increasing expected profit of the VPP. In contrast, for the approximate models, reserve cost increase and the result the expected profit decreases. These results show that the proposed strategy is more economic scheduling for the VPP.

## V. CONCLUSIONS

This paper proposed a two-stage risk-averse optimization model for energy and reserve scheduling of a VPP. By incorporating DR schemes into the model, the impacts of different options of DR participants on the decisions of the VPP were also discussed. Also, to cope with the uncertainties related with DA and RT market prices, RESs generations, loads and the uncertainty related to the calls for reserve services, a risk evaluation was incorporated using CVaR. The proposed model was verified on the 15-bus VPP system and numerical results showed that employing different types of DR actions can improve VPP's profit. However, their level of improvement is high when customers contribute to DR with both LS and LC mechanisms. Moreover, when the VPP behaves more risk averse, in all DR actions the trading energy with the main grid decreased due to the VPP that tried to provide its demand from its local DG units to eliminate the effect of volatility of market prices on its decisions.

Future works include developing this model for VPPs and co-optimizing the prosumers' revenue stream from their flexibility options considering peer to peer trading floor via a bi-level programming problem

#### REFERENCES

- [1] S. Babaei, C. Zhao, and L. Fan, "A Data-Driven Model of Virtual Power Plants in DA Unit Commitment," *IEEE Trans. Power Syst.*, vol. 34, no. 6, pp. 5125–5135, 2019.
- [2] S. Yin, Q. Ai, Z. Li, Y. Zhang, and T. Lu, "Energy management for aggregate presumes in a virtual power plant: A robust Stackelberg game approach," *Int Trans Electr Energy Syst.*, vol. 117, pp.e105605, 2020.
- [3] S. Hadayeghparast, A. SoltaniNejad Farsangi, and H. Shayanfar, "Day-ahead stochastic multi-objective economic/emission operational scheduling of a large scale virtual power plant," *Energy*, vol. 172, no. 1, pp.630-646, 2019.
- [4] X. Konga, J. Xiaoa, C. Wanga, K.Cuib, Q. Jinb, and D. Konga, "Bi-level multi-time scale scheduling method based on bidding for multioperator virtual power plant," *Applied Energy*, vol. 249, pp. 178–189, 2019.
- [5] J. Ponočko and J. V. Milanovi, "Forecasting demand flexibility of aggregated residential load using smart meter data," *IEEE Trans. Power Syst.*, vol. 33, no. 5, pp. 5446-5455, Sept. 2018.
- [6] S. Bahrami, and M. H. Amini, "A decentralized trading algorithm for an electricity market with generation uncertainty," *Applied Energy*, vol. 218, pp. 520–532, 2018.
- [7] S. Bahrami, M. H. Amini, Miadreza Shafie-khah, and Joao P. S. Catalao, "A Decentralized Electricity Market Scheme Enabling Demand Response Deployment," *Trans. on Power Systems*, vol. 33, no. 4, pp. 4218 – 4227, 2018.
- [8] Y. Kang, K. Lo, and I. Kockar, "Optimal energy management for virtual power plant with renewable generation," *Energy and Power Engineering*, vol. 9, no. 4, p. 308, 2017.
- [9] H. Trung Nguyen, L.B. Le, and Z. Wang, "A Bidding Strategy for Virtual Power Plants With Intraday Demand Response Exchange Market Using Stochastic Programming," *IEEE Transactions on Industry Applications*, vol. 54, no. 4, pp. 3044 – 3055, 2018.
- [10] Z. Liang, Q. Alsafasfeh, T. Jin, H. Pourbabak, and W. Su, "Risk-Constrained Optimal Energy Management for Virtual Power Plants Considering Correlated Demand Response," *IEEE Trans. Smart Grid*, vol. 10, no. 2, pp. 1577 - 1587, 2019.
- [11] E.G. Kardakos, C.K. Simoglou, A.G. Bakirtzis, "Optimal offering strategy of a virtual power plant: a stochastic bi-level approach," *IEEE Trans. Smart Grid*, vol. 7, no. 2, pp. 794–806, 2016.
- [12] A. Baringo, L. Baringo, and J. M. Arroyo, "Self-Scheduling of a Virtual Power Plant in Energy and Reserve Electricity Markets: A Stochastic Adaptive Robust Optimization Approach," *Trans. on Power Systems*, vol. 34, no. 3, pp. 1881 – 1894, 2019.
- [13] Z. Tan, G. Wang, L. Ju, Q. Tan, and W. Yang, "Application of CVaR risk aversion approach in the dynamical scheduling optimization model for virtual power plant connected with wind-photovoltaic-energy storage system with uncertainties and demand response," *Energy*, vol. 124, pp. 198-213, 2017.
- [14] Z. Yi, Y. Xu, W. Gu, and W. Wu, "A Multi-time-scale Economic Scheduling Strategy for Virtual Power Plant Based on Deferrable Loads Aggregation and Disaggregation," *Trans. on Sustainable Energy*, vol. 11, no. 3, pp. 1332 – 1346, 2020.
- [15] S. Rahmani Dabbagh and M. K. Sheikh-El-Eslami, "Risk Assessment of Virtual Power Plants Offering in Energy and Reserve Markets," *IEEE Trans. Power Syst.*, vol.31, no. 5, pp. 3572 – 3582, 2016.
- [16] Y. Zhou, Z. Wei, G. Sun, K.W. Cheung, H. Zang, and S. Chen, "Four-level robust model for a virtual power plant in energy and reserve markets," *IET Gene., Trans. & Distr.*, vol. 13, no. 11, pp. 2036-2043, 2019.
- [17] H. Nezamabadi, and M. Setayesh-Nazar, "Arbitrage strategy of virtual power plants in energy, spinning reserve and reactive power markets," *IET Gene., Trans. & Distr.*, vol. 10, no. 3, pp. 750 – 763, 2016.
- [18] A. Baringo, L. Baringo, and J. M. Arroyo, "Day-Ahead Self Scheduling of a Virtual Power Plant in Energy and Reserve Electricity Markets under Uncertainty," *IEEE Trans. Power Syst.*, vol. 34, no. 3, pp. 1881 - 1894, May 2019.
- [19] L. Ju, Z. Tan, J. Yuan, Q. Tan, H. Li, F. Dong, "A bi-level stochastic scheduling optimization model for a virtual power plant connected to a wind-photovoltaic-energy storage system considering the uncertainty and demand response," *Applied Energy*, vol. 171, pp.184-199, 2016.
- [20] M. Vahedipour-Dahraie, A. Anvari-Moghaddam, and J. M., Guerrero, "Evaluation of Reliability in Risk-Constrained Scheduling of Autonomous Microgrids with Demand Response and Renewable Resources," *IET Renew. Power Gener.*, vol. 12, no. 6, pp. 657-667, 2018.
- [21] G. Yuanxiong, and Z. Chaoyue, "Islanding-Aware Robust Energy Management for Microgrids", *IEEE Trans. on Smart Grid*, vol. 9, no. 2, pp. 1301-1309, 2018.
- [22] D. Arthur, and S. Vassilvitskii, "K-means++: The advantages of careful seeding," in Proc. SODA '07, New Orleans, pp. 1027-1035, 2007.
- [23] H. Rashidzadeh-Kermani, M. Vahedipour-Dahraie, M., Shafie-khah, and J. P. S. Catalão, "A bi-level risk-constrained offering strategy of a wind power producer considering demand side resources," *Int. J. Elec. Power & Energy Syst.*, vol. 104, pp. 562-574, 2019.
- [24] S.M. Nosratabadi, R-H. Hooshmand, E. Gholipour, "Stochastic profit-based scheduling of industrial virtual power plant using the best demand response strategy," *Applied Energy*, vol. 164, pp. 590-606, 2016.
- [25] S. Yu, F. Fang, Y. Liu, and J. Liu, "Uncertainties of virtual power plant: Problems and countermeasures," *Applied Energy*, vol. 239, pp. 454–470, 2019.
- [26] A.J. Conej, M. Carrion, and J.M. Morales, "Decision Making Under Uncertainty in Electricity Markets," New York, NY, USA: Springer, 2010.
- [27] J. Qiu, K. Meng, Y. Zheng, and Z.Y. Dong, "Optimal scheduling of distributed energy resources as a virtual power plant in a transactive energy framework," *IET Gen. Trans. Dist.*, vol. 11, no. 13, pp. 3417-3427, 2017.
- [28] "Relevant information on the market pertaining to Nordpool", available online: [www.Nordpool.com](http://www.Nordpool.com), [accessed on 5 September 2016]
- [29] D. Zh, S. Nilay, and P. Lazaros, "Efficient energy consumption and operation management in a smart building with microgrid," *Energy Convers Manag.*, 74, pp. 209-222, 2013.
- [30] S. Aghajani, and M. Kalantar, "Operational scheduling of electric vehicles parking lot integrated with renewable generation based on bilevel programming approach," *Energy*, vol. 139, pp. 422-432, 2017.
- [31] "The General Algebraic Modeling System (GAMS) Software", online available at: <http://www.gams.com>, [accessed on 15 September 2016]