

Integration of emerging resources in IGDT-based robust scheduling of combined power and natural gas systems considering flexible ramping products

Mohammad Amin Mirzaei¹, Ahmad Sadeghi Yazdankhah², Behnam Mohammadi-Ivatloo¹, Mousa Marzband³, Miadreza Shafie-khah⁴, João P. S. Catalão⁵

¹Faculty of Electrical and Computer Engineering, University of Tabriz, Tabriz, Iran

²Department of Electrical Engineering, Sahand University of Technology, Tabriz, Iran

³Department of Mathematics, Physics and Electrical Engineering, Northumbria University, Newcastle, England

⁴School of Technology and Innovations, University of Vaasa, 65200 Vaasa, Finland

⁵Faculty of Engineering of the University of Porto and INESC TEC, 4200-465 Porto, Portugal

Abstract

Wind energy sources have created new challenges in power system scheduling to follow the network load. Gas fired units with high ramping could better deal with inherent uncertainties of wind power compared to other power generation sources. The natural gas system constraints affect the flexibility of natural gas-fired power plants in the electrical market. In this paper, three solutions have been proposed to cover the challenges of gas system constraints and the uncertainty of wind power: 1) using information-gap decision theory (IGDT) based robust approach to address the uncertainty caused by the intrinsic nature of wind power, 2) Integration of compressed air energy storage (CAES), and demand response (DR) in day-ahead scheduling and 3) considering flexible ramping products in order to ensure reliable operations, there must be enough ramp to eliminate the variability of wind power in real-time dispatch stage. This paper proposes an IGDT-based robust security constrained unit commitment (SCUC) model for coordinated electricity and natural gas systems with the integration of wind power and emerging flexible resources while taking the flexible ramping products into account.

Numerical tests demonstrate the effect of emerging flexible resources on a reduction of system operation cost and the uncertainty of predicted wind power.

Keywords: Information-gap decision theory, combined power, and natural gas systems, demand response, compressed air energy storage, emerging flexible resources, flexible ramping products.

Index:

t	Index of time
i	Index of power plant
w	Index of wind power plant
k	Index of CAES unit
b, b'	Index of buses
j	Index of loads
L	Index of transmission lines
pl	Index of pipelines
m, n	Index of nodes in gas system

Constants:

NT	Sum of time periods
NU	Sum of thermal units
NW	Sum of wind power plants
NGS	Sum of gas suppliers
NGU	Sum of gas-fired units
NGL	Sum of gas loads
NB	Sum of buses
$DR_{j,t}^{\max}$	Maximum adjustable load

P_i^{\max}, P_i^{\min}	Max/min generation capacity of power plant i
$P_{r,t}$	Forecasted wind power
$\alpha_i, \beta_i, \gamma_i$	Fuel function coefficient of gas-fired units
RU_i, RD_i	Ramp up/down power plant i
T_i^{On}, T_i^{Off}	Minimum up/down time of unit i
X_L	Reactance of line L
PF_L^{\max}	Capacity of line L
$d_{j,t}$	Expected hourly load
$P_{k,\max}^D, P_{k,\max}^H$	Max generation/storing capacity of CAES system
HR_k	Heat rate of CAES
C_{pl}	Constant of pipeline pl
$\pi_m^{\max}, \pi_m^{\min}$	Max/min pressure
$U_{sp}^{\max}, U_{sp}^{\min}$	Max/min gas supply
L_l^{\max}, L_l^{\min}	Max/min gas load
A_k^{\max}, A_k^{\min}	Max/min power stored in CAES system
$RFRU_t / RFRD_t$	System upward/downward flexible ramping reserve requirement
$C_{i,t}^{FRU}, C_{i,t}^{FRD}$	Upward/downward flexible ramping reserve cost of thermal unit
$C_{k,t}^{H,FRU}, C_{k,t}^{H,FRD}$	Upward/downward flexible ramping reserve cost of CAES unit in storage mode
$C_{k,t}^{D,FRU}, C_{k,t}^{D,FRD}$	Upward/downward flexible ramping reserve cost of CAES unit in generation mode

Variables:

F_i^T	Cost function of thermal unit i
F_k^D	Cost function of CAES system
$SU_{i,t}, SD_{i,t}$	Start-up/Shut-down cost of thermal unit i
$P_{i,t}$	Dispatch of thermal unit i
$FRU_{i,t}, FRD_{i,t}$	Upward/downward flexible ramping reserve provided by generation unit i
$I_{i,t}$	Binary on/off status indicator of power plant i
$X_{i,t-1}^{on}, X_{i,t-1}^{off}$	Up/down time of unit i
$PF_{L,t}$	Power flow at line L
$\delta_{b,t}$	Voltage angle of power buses
$I_{k,t}^H, I_{k,t}^D$	Binary storage/generation status indicator of CAES system
$P_{k,t}^H, P_{k,t}^D$	Storing/generation power of CAES
$FRU_{k,t}^D, FRD_{k,t}^D$	Upward/downward flexible ramping reserve provided by CAES system in generation mode
$FRU_{k,t}^H, FRD_{k,t}^H$	Upward/downward flexible ramping reserve provided by CAES system in storage mode
$A_{k,t}$	Power stored in CAES system
$d_{j,t}^{DR}$	Electric load after implementation of DR program
$dr_{j,t}$	Shiftable load
$F_{pl,t}$	Natural gas flow of pipe pl at time t
$L_{l,t}$	Natural gas load at time t

$\pi_{m,t}$ Pressure of natural gas node at time t

$U_{sp,t}$ Gas supply at time t

1.1. Motivation and problem description

In the last decades, global concerns over climate change and fossil fuel decrement have led to a recent worldwide push towards electricity derived from renewable resources. According to the International Energy Agency's (IEA) prediction, annual wind energy production will rise to 2182 TWh by 2030, which is seven times more comparing to the production up to 2009 [1]. By increasing penetration of renewable energy, the future electricity network will face various challenges originating from supply variability. Fast respond to such fluctuations requires the generation fleet flexibility with the object of having a balance between generation and consumption with minimum system operation cost. Higher power grid operational flexibility could be achieved by system operation improvement [2-4], using fast start resources [5], using emerging flexible resources [6, 7], and improving grid infrastructure. Practically, in order to improve system operation, designing new markets, using new models and algorithms in the process of unit commitment [8, 9] and modeling the uncertainty of renewable energy sources are the main concerns [10]. In this matter, an active market so-called "flexiramp" in California independent system operator (CAISO) has been developed to compensate a partial loss of traditional plants and cheer them to provide flexible ramping products [11]. Midcontinent independent system operator (MISO) is another market with ramp capability along with energy and contingency reserve markets to cover sudden net load variations in real-time dispatch stage [12].

Electricity and natural gas systems as an integrated energy system with the following advantages; promoting 60% less carbon concerning coal units, higher efficiency, fast start-up and higher ramp

rate capability (modern gas-fueled plants having startup time of lower than 1 h) has been deployed rapidly in recent years [13]. In the electricity market, independent system operator (ISO) performs security constraint unit commitment (SCUC) to minimize the cost of operation. So, the interdependency of power and natural gas systems faces ISO with new challenges. For example, pressure reduction at the nodes of the gas system (because of increasing gas consumption by residential and commercial loads) reduces the consuming fuel and power generation of the gas-fueled units, as a result, the system reliability will be decreased, and the operation cost is increased. In February 2012, because of not considering the interdependency of electricity and natural gas networks, the south portion of Germany power network was close to breaking down [13].

In recent years, increasing the penetration of the renewable energy resources interests researchers to use emerging technologies like energy storage systems (ESSs) and demand response (DR) programs and Electric Vehicles (EVs). Among the ESSs, compressed air energy storages (CAES) gain more interest recently due to the availability and lower investment cost comparing to the pumped energy storage units [14]. Aside from the pumped energy storage unit, CAES is suitable for large-scale power system and high energy storage application among the other energy storage technologies. Also, due to the high ramp rate capability of CAES, it plays an important role in the ancillary services market [15]. DR programs with load shifting property, reduce electricity consumption at peak load hours and increase it at low load hours. As a result, these programs reduce the electricity price, peak load shaving, the impact of wind power uncertainty, and the system operation cost [16]. Referring to the high potential of emerging flexible resources, coordinated scheduling of these resources compensates the challenges of renewable energy uncertainty and effectively responds to the interdependency issues of power and natural gas in day-ahead network-constrained scheduling.

The objective of this paper is to study the impact of emerging flexible resources by presenting an information gap decision theory (IGDT) based robust scheduling of combined power and natural gas systems considering flexible ramping products. The IGDT based robust method is a non-probabilistic optimization-based method that looks for a robust approach to model the wind power generation uncertainty. In this method, the probabilistic distribution function (PDF) of the uncertainty does not need to be specified.

1.2. Literature review and contribution

In recent years, various studies have been done on the interdependency of coupled power- natural gas system. In [17, 18] the effect of natural gas system constraints on a deterministic unit commitment problem has been evaluated without considering RESs. Authors in [19-21] have used Benders decomposition, the augmented LR, and alternating direction method of multipliers (ADMM) optimization algorithms to relax the electricity and natural gas coupling constraints in day-ahead scheduling of coordinated electricity and natural gas network. In [22] has been solved a stochastic SCUC problem for integrated power and gas systems to manage the variability of wind power generation. In [23], the impact of uncertainties in natural gas delivery and the variability of natural gas price on natural gas-fired unit generation scheduling has been investigated by solving a two-stage stochastic UC problem. In [24], the impact of applying power to gas (P2G) technology to the coordinated power and natural gas networks in Great Britain without considering the complete specifications of these two networks has evaluated. Robust scheduling of coordinated electricity and natural gas networks with the inclusion of natural gas storage system has been proposed in [25]. Ref [26] has focused on the robust scheduling of coordinate electricity and natural gas networks with the integration of wind energy and P2G technology. In [27], an integrated market clearing for power and gas networks under the uncertainties of electric demand

and wind power has been solved using two-stage stochastic programming. A problem of two-stage robust co-optimization scheduling has been investigated in [28] for coupled power and gas systems considering the uncertainties of power and gas network.

Some literature corresponds to the impact of emerging flexible resources in power systems operation. In [29] the impact of compressed air energy storage (CAES) unit on system operation cost has been shown by solving the conditional value at risk (CVaR)-based stochastic look-ahead problem with the integration of wind power. The effect of CAES system on system operation cost, wind power uncertainty, and static voltage stability (SVS) improvement has been discussed in [30] by solving the stochastic based SCUC problem. Ref [31] corresponds to the impact of DR on reducing the interdependency of power and natural gas systems and system operation cost in coordinated power and natural gas systems. A stochastic approach to conduct the day-ahead scheduling of the integration of WES and cryogenic energy storage with the demand response program has been provided in [32]. A bi-level optimization problem has been solved for coordinated operation of electricity and natural gas networks to maximize the profit of utility companies considering DR based virtual power plants in [33]. Incorporation of emerging flexible resources such as CAES unit DR programs and plug-in electric vehicle parking lots (PEV-PLs) has been proposed in [34] to reduce the daily operation cost as well as environmental pollution by solving a multi-objective stochastic UC. Ref. [35] corresponding to the impact of emerging flexible resources including ESS, DR, and PEV- PLs on operation cost reduction and load power curtailment in a two-stage stochastic network-constrained market clearing problem. The author in [36] has solved the SCUC problem with the inclusion of units ramp cost to discuss the impact of hourly DR on generation and ramp costs. Ref. [37] has addressed the effect of DR and ESS on the system operation using a two-stage stochastic SCUC with the integration of wind energy and

taking the account the units ramp cost. In [36] and [37] the authors have not considered the flexible ramping reserve market.

Some literature corresponds to consider flexible ramping products (FRPs) in the electrical market. The existence of flexible ramping products (FRPs) in ISO-based markets has been discussed in [38] by solving both deterministic and stochastic real-time unit commitment (RTUC) while ignoring transmission line constraints. In [39], the benefits of adapting FRPs by EVs has been considered as the major concern for a deterministic model using dynamic programming. In [40], two-stage stochastic scheduling has been proposed for combined power, and natural gas systems with DR and FRPs have been included. This literature has assessed the effects of natural gas system constraints on the participant of gas-fired units in energy and flexible ramping markets. Also, it determines the impact of DR on the reduction of the unit's production and flexible ramping reserve cost. The impact of coordinated emerging flexible resources (EES, DR, and PEV- PLs) on the daily operation cost, wind power spillage, and involuntary load shedding in energy, spinning and flexible ramping reserve market clearing problem has been presented in [41]. This literature has focused only on the electricity network, and the constraints of the natural gas network have not been considering.

In the reports mentioned above, uncertainties of the systems have been handled by stochastic and well-known robust optimization approaches. Information gap decision theory (IGDT) is a non-probabilistic method which does not need any probability density function (PDF) or fuzzy logic membership. IGDT approach does not require scenario generation. So, the problem solution time is less than the stochastic approach. Therefore, simplification hypotheses of the stochastic approaches make them inadequate for solving largescale problems. IGDT is applicable for the realization of robust decision-making strategies. The IGDT has been proposed in [42] for bidding

strategies of generation companies, in [43] for UC, in [44] for the restoration of distribution networks. In [43], an IGDT based self-scheduling problem has been solved to maximize generation companies profit. In this literature, the electricity price has been considered an uncertain variable. Ref. [45] corresponds to an IGDT based SCUC problem with the integration of Li-ion battery storage unit considering the uncertainty of network load. Finally in [46], the IGDT based SCUC problem with the inclusion of ESS, DR program and transmission switching has been proposed.

In this paper, the integration of wind power, CAES technology and price-based DR program in IGDT based robust SCUC model for coordinated power and natural gas systems considering flexible ramping products have been proposed which is shown in Fig. 1. It should be noted that four types of approaches are considered in the literature to address interdependency between the power and gas systems. 1) Including the gas system limits into power system optimization problem (i.e., security-constrained unit commitment), 2) incorporating dynamic gas consumptions of the electric power system into gas system optimization models, 3) sequential optimization of the electricity grid and the natural gas network and 4) integrated co-optimization of the power and gas systems [1]. This paper has focused on including the gas system limits into power system optimization problem (first strategy). Table 1 demonstrates comparison of the literature with the current work for optimal operation of integrated gas and power networks.

The main features of the paper are as follows:

- Applying IGDT as a non-probabilistic method with no need to PDF and fuzzy logic membership for modeling the uncertainty of wind power.

- Considering FRPs in IGDT based robust SCUC model for coordinated power and natural gas networks, so that the natural gas network limits affect the provision of FRPs by gas-fired power plants.
- Considering emerging flexible resources such as CAES, DR program to reduce the effect of natural gas network constraints, wind power uncertainty on the costs of energy and flexible ramp.

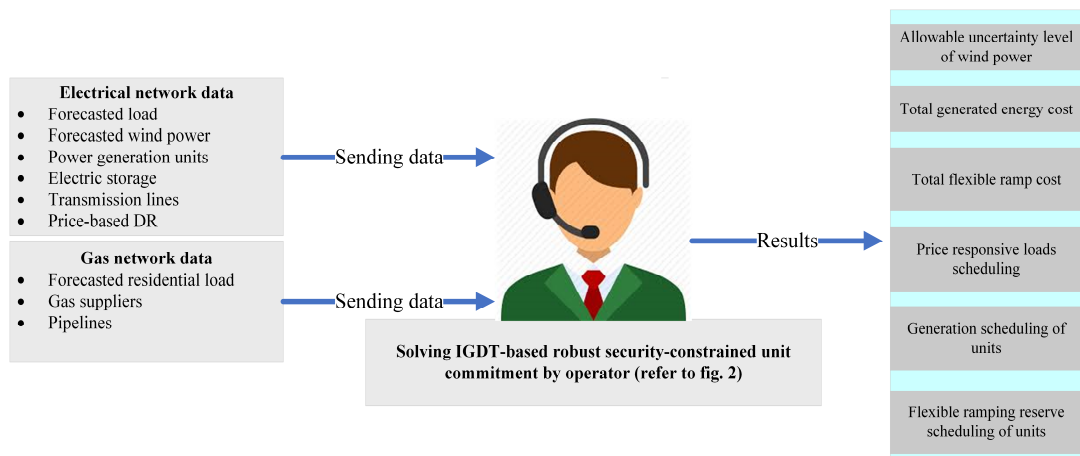

Fig. 1. The overall illustration of the presented framework

Table. 1. Comparison of the literature with the current work

References	Year	Coordinated electricity and natural gas networks	DR program	Electrical storage system	Uncertainty modeling	Wind uncertainty	Flexible ramping products
[22]	2015	✓			Stochastic	✓	
[31]	2016	✓	✓		Stochastic		
[40]	2016	✓	✓		Stochastic	✓	✓
[25]	2017	✓			Robust		
[24]	2018	✓			Robust	✓	
[27]	2018	✓			Two-stage stochastic	✓	
[28]	2018	✓			Two-stage robust	✓	
Proposed model		✓	✓	✓	IGDT	✓	✓

2. Problem formulation

The SCUC problem for coordinated electricity and natural gas networks considering emerging flexible resources and flexible ramping products is modeled as a mixed-integer non-linear programming (MINLP) as given by Eq. (1). The objective function will minimize the system operation cost and has two parts. The first part is minimized the hourly generation cost and the flexible ramping cost for power plants considering system constraints. The second part corresponds to the power generation cost and flexible ramping cost of CAES system.

$$\min \sum_{t=1}^{NT} \left[\sum_{i=1}^{NU} \left[F_i^T (P_{i,t}) + SU_{i,t} + SD_{i,t} + C_{i,t}^{FRU} FRU_{i,t} + C_{i,t}^{FRD} FRD_{i,t} \right] + \sum_{k=1}^{NK} \left[F_k^D (P_{k,t}^D) + C_{k,t}^{D,FRU} FRU_{k,t}^D + C_{k,t}^{D,FRD} FRD_{k,t}^D + C_{k,t}^{H,FRU} FRU_{k,t}^H + C_{k,t}^{H,FRD} FRD_{k,t}^H \right] \right] \quad (1)$$

Where $F_i^C (P_{i,t})$ and $F_k^D (P_{k,t}^D)$ are defined as follows:

$$F_i^T (P_{i,t}) = \lambda^{gas} (\alpha_i + \beta_i P_{i,t} + \gamma_i P_{i,t}^2) \quad (2)$$

$$F_k^D (P_{k,t}^D) = \lambda^{gas} HR_k P_{k,t}^D \quad (3)$$

In minimizing the objective function, several constraints are considered as follows:

2.1 Thermal unit constraints

The upward and downwards flexible ramping reserves of an online thermal unit does not exceed the rated value over the entire scheduling time interval or ramp response time as shown in Eqs. (4) and (5). The upward and downward flexible ramping reserve is bounded by the unloaded power capacity of the thermal unit in Eqs. (6) and (7). A unit ramp rate limits in the consecutive interval are satisfied in Eqs. (8), (9), (10) and (11). Minimum up/down time for each unit is dictated by Eqs. (12) and (13). The start-up / shut-down cost of the units is defined by Eqs. (14) and (15).

$$0 \leq FRU_{i,t} \leq R_i^{up} \tau \quad (4)$$

$$0 \leq FRD_{i,t} \leq R_i^{dn} \tau \quad (5)$$

$$P_{i,t} + FRU_{i,t} \leq P_i^{\max} I_{i,t} \quad (6)$$

$$P_{i,t} - FRD_{i,t} \leq P_i^{\min} I_{i,t} \quad (7)$$

$$P_{i,t} - P_{i,t-1} + FRU_{i,t} + FRU_{i,t-1} \leq (1 - Y_{i,t}) R_i^{up} + Y_{i,t} P_i^{\min} \quad (8)$$

$$P_{i,t-1} - P_{i,t} + FRD_{i,t} + FRD_{i,t-1} \leq (1 - Z_{i,t}) R_i^{dn} + Z_{i,t} P_i^{\min} \quad (9)$$

$$Y_{i,t} - Z_{i,t} = I_{i,t} - I_{i,t-1} \quad (10)$$

$$Y_{i,t} + Z_{i,t} \geq 1 \quad \forall i, \forall t \quad (11)$$

$$(X_{i,t-1}^{on} - T_i^{on})(I_{i,t-1} - I_{i,t}) \geq 0 \quad (12)$$

$$(X_{i,t-1}^{off} - T_i^{off})(I_{i,t} - I_{i,t-1}) \geq 0 \quad (13)$$

$$SU_{i,t} \geq SUC_i (I_{i,t} - I_{i,t-1}) \quad (14)$$

$$SD_{i,t} \geq SUD_i (I_{i,t-1} - I_{i,t}) \quad (15)$$

2.2 CAES system constraints

In the proposed optimization model, in the following modes for CAES are considered: generation, compression, and idling. To include all three modes in the model, Eq. (16) is considered.

$$I_{k,t}^H + I_{k,t}^D \leq 1 \quad (16)$$

Where $I_{k,t}^{CH}$ and $I_{k,t}^D$ are introduced as binary variables in the state of compression and generation.

The amount of generated or stored power by CAES system considering upward and downward flexible ramping reserve is declared by Eqs. (17) to (20). The level of stored energy in the CAES

system in each hour is fulfilled by Eq. (21). Eqs. (22) and (23) define the upper and lower bound of the stored energy.

$$P_{k,t}^H + FRD_{k,t}^H \leq P_{k,\max}^H I_{k,t}^H \quad (17)$$

$$P_{k,t}^{CH} - FRU_{k,t}^{CH} \geq P_{k,\min}^{CH} I_{k,t}^{CH} \quad (18)$$

$$P_{k,t}^D + FRU_{k,t}^D \leq P_{k,\max}^D I_{k,t}^D \quad (19)$$

$$P_{k,t}^D - FRD_{k,t}^D \geq P_{k,\min}^D I_{k,t}^D \quad (20)$$

$$A_{k,t} = A_{k,t-1} + \eta_k^H P_{k,t}^H - \frac{P_{k,t}^D}{\eta_h^D} \quad (21)$$

$$A_{k,t} + FRD_{k,t}^H \leq A_k^{\max} \quad (22)$$

$$A_{k,t} - FRU_{k,t}^D \geq A_k^{\min} \quad (23)$$

Initial capacity of storage system is defined by Eq. (24), and Eq. (25) indicates that the initial ($t = 0$) and final ($t = 24$) values of the stored power in CAES system are the same.

$$A_{k,0} = A_{k,in} \quad (24)$$

$$A_{k,0} = A_{k,NT} \quad (25)$$

2.3 Demand response constraints

DR programs are described as incentive-based DR and price-based DR. In incentive-based DR, the customers bid their electricity consumption reduction to the ISO, and if their bid is accepted after the implement of market clearing, the consumer has to do the contract and receive the cost of their power consumption reduction. Therefore, in this approach, the cost of DR is considered in the objective function of SCUC problem by ISO. On the other hand, based on the price-based DR programs, price-responsive loads are shifted from high price to low price in the required time interval. As a result, in this model, no cost is considered in SCUC problem by ISO. This paper has

focused on price-based DR that has been modeled as price responsive shiftable loads. Eq. (26) shows the network load after the implement of DR program, and Eq. (27) defines the amount of hourly shiftable load. The total shifted load for the whole time duration is zero as defined in Eq. (28). The hourly adjustable load has to be limited as Eq. (29).

$$d_{j,t}^{DR} = d_{j,t} + dr_{j,t} \quad (26)$$

$$dr_{j,t} = DR_{j,t} d_{j,t} \quad (27)$$

$$\sum_{t=1}^{NT} dr_{j,t} = 0 \quad (28)$$

$$|DR_{j,t}| \leq DR_{j,t}^{\max} \quad (29)$$

2.4 Electricity network Security Constraints

System power balance constraint is determined as Eq. (30). Line power flow (from bus b to bus b') and transmission line capacity are given by Eqs. (31) and (32), respectively. Constraints related to system upward/downward flexible ramping reserve requirement are expressed as Eqs. (33) and (34).

$$\sum_{i=1}^{NU_b} P_{i,t} + \sum_{w=1}^{NW_b} P_{w,t} + \sum_{k=1}^{NK_b} P_{k,t}^D - \sum_{k=1}^{NK_b} P_{k,t}^H - \sum_{j=1}^{NJ_b} d_{j,t}^{DR} = \sum_{l=1}^{NL_b} PF_{L,t} \quad (30)$$

$$PF_{L,t} = \frac{\delta_{b,t} - \delta_{b',t}}{x_L} \quad (31)$$

$$-PF_L^{\max} \leq PF_{L,t} \leq PF_L^{\max} \quad (32)$$

$$\sum_{i=1}^{NU} FRU_{i,t} + \sum_{k=1}^{NK} FRU_{k,t}^D + \sum_{k=1}^{NK} FRU_{k,t}^H \geq RFRU_t \quad (33)$$

$$\sum_{i=1}^{NU} FRD_{i,t} + \sum_{k=1}^{NK} FRD_{k,t}^D + \sum_{k=1}^{NK} FRD_{k,t}^H \geq RFRD_t \quad (34)$$

2.5 Natural Gas Network Constraints

The natural gas transportation system transports the natural gas from supplies to the large user.

The natural gas flow through a pipeline is dictated as a quadratic function of the pressure at the two end nodes:

$$F_{pl,t} = \text{sgn}(\pi_{m,t}, \pi_{n,t}) C_{m,n} \sqrt{|\pi_{m,t}^2 - \pi_{n,t}^2|} \quad (35)$$

$$\text{sgn}(\pi_{m,t}, \pi_{n,t}) = \begin{cases} 1 & \pi_{m,t} \geq \pi_{n,t} \\ -1 & \pi_{m,t} < \pi_{n,t} \end{cases} \quad (36)$$

where $C_{m,n}$ is pipeline constant, which depends on temperature, diameter, length, friction, and natural gas compositions. Natural gas pressure at each node and natural gas delivery are limited according to Eqs. (37) and (38). Natural gas load consumption at any node is stated as Eq. (39), and Eq. (40) preserves the natural gas flow balance at each node.

$$\pi_m^{\min} \leq \pi_{m,t} \leq \pi_m^{\max} \quad (37)$$

$$U_{sp}^{\min} \leq U_{sp,t} \leq U_{sp}^{\max} \quad (38)$$

$$L_l^{\min} \leq L_{l,t} \leq L_l^{\max} \quad (39)$$

$$\sum_{sp=1}^{NGS_m} U_{sp,t} - \sum_{l=1}^{NGL_m} L_{l,t} = \sum_{pl=1}^{NPL_m} F_{pl,t} \quad (40)$$

2.6 Coupling constraints for electricity and natural gas networks

Natural gas-fired power plants are the large consumers of natural gas fuel. The production capacity of these plants depends on natural gas transportation utilities. Eq. (41) defines the amount of

natural gas consumed by natural gas-fueled power plants. $FRUF_{i,t}$ presents the amount of natural gas fuel assigned for the use of upward flexible ramping reserve of natural gas-fired plants at the real-time power dispatch. Eq. (42) links CAES unit to the natural gas network. Daily consumption of natural gas by natural gas-fueled power plants and CAES considering upward flexible ramping reserve is dictated as (43) and (44). Where the higher heating value (HHV) is 1.026 MBtu/kcf.

$$L_{i,t} = \frac{\alpha_i + \beta_i P_{i,t} + \gamma_i P_{i,t}^2 + SU_{i,t} + SD_{i,t} + FRUF_{i,t}}{HHV} \quad i \in GU \quad (41)$$

$$L_{i,t} = \frac{HR_k P_{k,t}^D + FRUF_{k,t}^D}{HHV} \quad (42)$$

$$\sum_{t=1}^{NT} \frac{\alpha_i + \beta_i P_{i,t} + \gamma_i P_{i,t}^2 + SU_{i,t} + SD_{i,t} + FRUF_{i,t}}{HHV} \leq FU_i^{\max} \quad (43)$$

$$\sum_{t=1}^{NT} \frac{HR_k P_{k,t}^D + FRUF_{k,t}^D}{HHV} \leq FC_K^{\max} \quad (44)$$

3. Implementing IGDT on SCUC problem

In order to deal with wind power generation uncertainty, IGDT is utilized SCUC formulation. For computational approaches to the stochastic modeled optimization problem, the PDF of the wind power generation uncertainty should be specified while in the proposed IGDT method there is no need to specify the PDF and fuzzy logic membership which is necessary for the cases of high penetration of wind power generation uncertainty. On the other hand, IGDT based robust optimization problem like well-known robust optimization (RO) problems causes an increase in the operation cost in comparison to stochastic optimization but the system will be robust against the uncertainties. In addition, in IGDT based robust model, we will generally face a bi-level

problem that cannot be solved by well-known optimization software and it is necessary to convert the introduced bi-level problem into a single optimization using Karush–Kuhn–Tucker (KKT) condition or innovative method in order to solve with common optimization software. Additionally, unlike the well-known RO methods [42, 43] that the lower and upper level of the uncertainty band must be determined as input parameter, there is no requirement to specify the lower and upper level of uncertainty band in the IGDT method.

In RO approach, robustness region of the uncertain parameter is constant before solving the problem. Actually, this is one of the issues of RO approach while this region is calculated in the process of solving the IGDT approach so that the solution is robust for a maximized interval of uncertainty. In other words, the uncertainty band in other methods is described as the input of the process of optimization, and the aim of the decision-maker is maximizing the objective function. Unlike the other approaches applied for modeling the uncertain parameter in optimization problems, which optimizes the objective function, the objective of the IGDT based robust method is maximizing the acceptable interval of uncertainty considering a predefined acceptable objective function (e.g., predefined acceptable operation cost), which is another benefit of IGDT approach [44]. This method maximizes the interval of wind power generation uncertainty by adjusting decision variables to achieve the robust optimum solution which guarantees an acceptable value for the objective function.

The mathematical model of the proposed IGDT based robust SCUC model is described as (45) which is a bi-level optimization problem.

$$\alpha(x, \Delta_c) = \max \left\{ \varepsilon : \left(\max_{\Psi \in U(\bar{\Psi}, \varepsilon)} of \leq \Delta_c = (1 + \beta_r) of_b \right) \right\} \quad (45)$$

Where Ψ defines a set of uncertain input parameters in the uncertainty set U . Δ_c and of_b are the acceptable level and the base level of the objective function, respectively. This acceptable level can be different for market operators in different countries and depends on various social welfare, economic, reliability and other issues that adjusts by parameter β_r . β_r is the degree of robustness against the operation cost increment with respect to the base case value and x is a set of decision variables. Mathematical description of representing the required information about Ψ is described by

$$U = U(\bar{\Psi}, \varepsilon) = \left\{ \Psi : \left| \frac{\Psi - \bar{\Psi}}{\bar{\Psi}} \right| \leq \varepsilon \right\} \quad (49)$$

Where $\bar{\Psi}$ is the forecasted value of Ψ and ε denotes the maximum deviation of the uncertain parameter from its predicted value (unknown radius of uncertainty for decision making). In this approach, the uncertain parameter has an undesirable impact on the objective function. Therefore, the system operator takes into account a higher cost associated with the undesirable deviation of wind power in this approach, which is given by (50)-(54) as a bi-levels problem.

$$\alpha = \max \varepsilon \quad (50)$$

$$\max \sum_{t=1}^{NT} \left[\sum_{i=1}^{NU} [F_i^T(P_{i,t}) + SU_{i,t} + SD_{i,t} + C_{i,t}^{FRU} FRU_{i,t} + C_{i,t}^{FRD} FRD_{i,t}] + \sum_{k=1}^{NK} [F_k^D(P_{k,t}^D) + C_{k,t}^{D,FRU} FRU_{k,t}^D + C_{k,t}^{D,FRD} FRD_{k,t}^D + C_{k,t}^{H,FRU} FRU_{k,t}^H + C_{k,t}^{H,FRD} FRD_{k,t}^H] \right] \leq \Delta_c \quad (51)$$

$$\Delta_c = (1 + \beta_r) of_b \quad (52)$$

$$\hat{P}_{w,t} (1 - \varepsilon) \leq P_{w,t} \leq \hat{P}_{w,t} (1 + \varepsilon) \quad (53)$$

$$\text{s.t. (2) - (44)} \quad (54)$$

The proposed bi-level problem is hard to solve with common mathematical software and it is necessary to convert it into a single-level optimization problem. In this paper, the proposed bi-level IGDT-SCUC problem is converted to a single level problem using an innovative method. The forecast error of wind power in this approach is modeled in a way that increases the operation cost. Therefore, in this approach, only a reduction in wind power has an undesirable effect on the system operation cost. As a result, the bi-level problem given in (50)-(54) can be converted into a single-level problem as follows.

$$\alpha = \max \varepsilon \quad (55)$$

$$\sum_{t=1}^{NT} \left[\sum_{i=1}^{NU} [F_i^T(P_{i,t}) + SU_{i,t} + SD_{i,t} + C_{i,t}^{FRU} FRU_{i,t} + C_{i,t}^{FRD} FRD_{i,t}] + \sum_{k=1}^{NK} [F_k^D(P_{k,t}^D) + C_{k,t}^{D,FRU} FRU_{k,t}^D + C_{k,t}^{D,FRD} FRD_{k,t}^D + C_{k,t}^{H,FRU} FRU_{k,t}^H + C_{k,t}^{H,FRD} FRD_{k,t}^H] \right] \leq \Delta_c \quad (56)$$

$$\Delta_c = (1 + \beta_r) of_b \quad (57)$$

$$\sum_{i=1}^{NU_b} P_{i,t} + \sum_{w=1}^{NW_b} P_{w,t} (1 + \varepsilon) + \sum_{k=1}^{NK_b} P_{k,t}^D - \sum_{k=1}^{NK_b} P_{k,t}^H - \sum_{j=1}^{NJ_b} d_{j,t}^{DR} = \sum_{l=1}^{NL_b} PF_{L,t} \quad (58)$$

$$\text{s.t. (2) - (29) and (31) - (44)} \quad (59)$$

It is worth to mention that in the base case, emerging flexible resources such as DR and CAES are not included in the model. The flowchart of the single-level IGDT-SCUC problem is shown in Fig.

2. by details

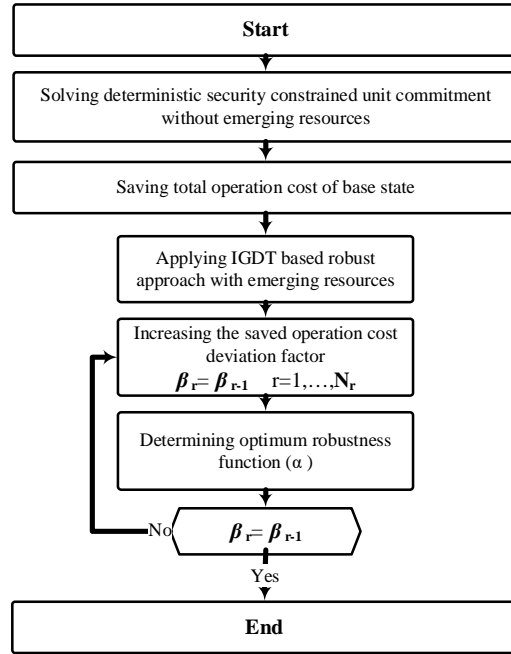

Fig. 2. The proposed single-level IGDT based robust SCUC model

4. Numerical studies

The proposed IGDT-based robust SCUC problem for coordinated power and natural gas networks considering DR and CAES flexible resources is evaluated on a modified 6-bus power system with a six-node natural gas system and modified IEEE-RTS 24-bus system with a ten-node natural gas system. The proposed model is the MINLP problem which is solved using GAMS / DICOPT solver.

4.1. Modified six-bus system

The modified six-bus system depicted in Fig. 3 consists of three gas-fired units, three electric loads, seven transmission lines, one wind farm, and one CAES unit. The electrical power and transmission line data are given in [20]. The forecasted load profile and wind power are shown in Fig. 4. The six-node natural gas system consists of five pipelines, two gas producers, and six natural gas loads (three gas-fired plants one CAES system, and two residential gas loads). The natural gas system data are given in [20]. The cost of upward and downward flexible ramping products caused by thermal plants is assumed 20% of their respective first-order coefficients [40]. The cost of CAES

system is defined as the price of natural gas multiplied by its heat rate. In this research, it is assumed 4.5 \$/MW. The corresponding upward and downward flexible ramping reserve cost of CAES system is considered 20% of its operating cost.

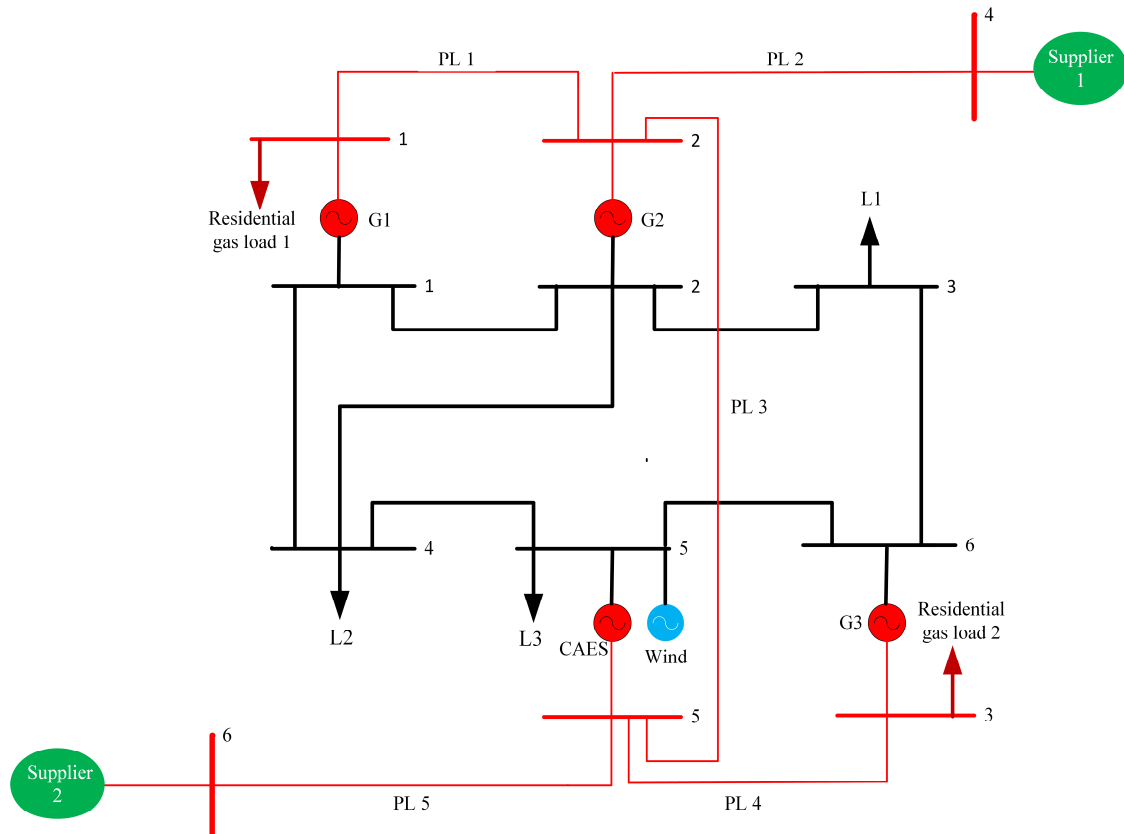

Fig. 3. Illustration of 6-bus electrical and 6-node natural gas systems with wind and CAES unit

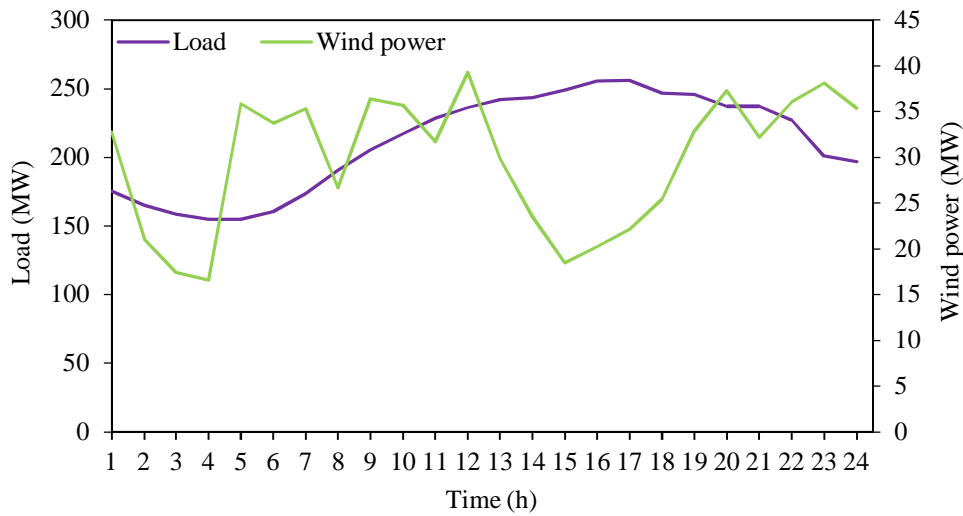

Fig. 4. Forecasted electric load and wind power generation

The following six cases are considered to evaluate the proposed model:

Case 1: SCUC solution considering flexible ramping products.

Case 2: Case 1 with considering natural gas constraints.

Case 3: Case 2 with the integration of CAES system.

Case 4: Case 2 with the inclusion of DR program.

Case 5: Case 2 with the coordination of DR and CAES.

Case 6: IGDT based robust SCUC for cases 2-5.

Case 1: this case provides the SCUC solution considering flexible ramping products. Natural gas transmission system constraints are not considered. Hourly generation dispatch and upward/downward flexible ramping reserve provided by natural gas-fired plants are in Figs. 5 and 6. The cheapest thermal unit G1 is on at all 24 hours while the most expensive unit G2 is turned on between hours 14-18 to satisfy the remaining load. As shown in Fig. 6, most of the time required

upward and downward flexible ramping reserves are produced by G1. Due to the ramp rate limit of unit G1 at consecutive hours, some part of downward flexible ramp reserve is available on unit G3. The total operation cost, in this case, is \$70159.26 consisting of \$67319.48 production cost and \$2839.78 flexible ramping reserve cost.

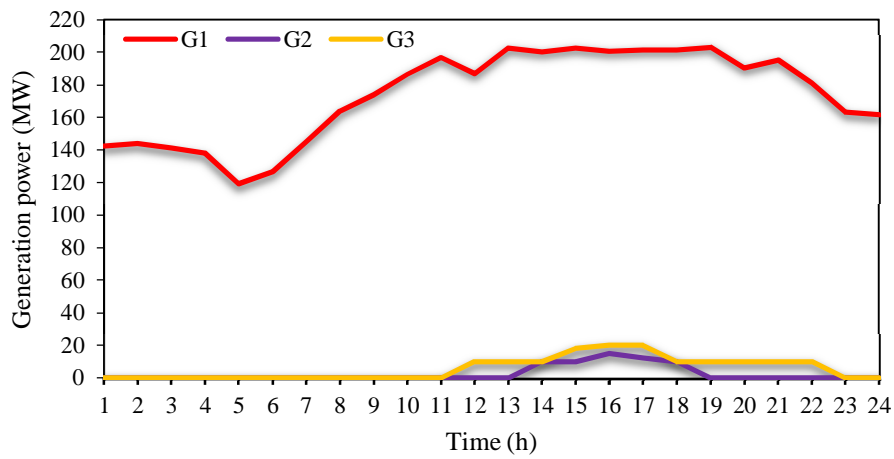

Fig. 5. Hourly generation dispatch of units

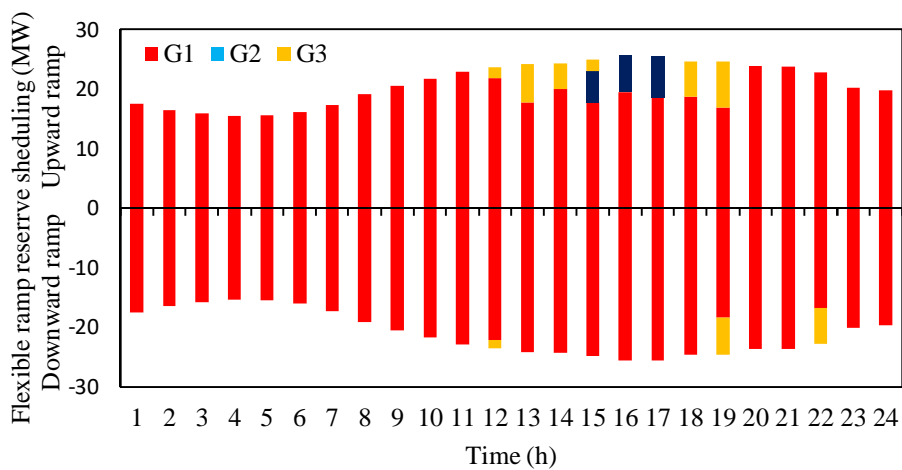

Fig. 6. Flexible ramp reserve scheduling

Case 2: In this case, the SCUC problem with flexible ramping products is solve considering natural gas network constraints. Fig. 7 demonstrates the effect of natural gas delivery limits on hourly generation dispatch of units G1 and G2 based on residential gas load profile. As shown in this Figure, the hourly dispatch of unit G1 compared to the results of case 1 has been reduced at residential gas load pick hours. As a result, the hourly dispatch of unit G2 is increased from 57.36 MWh in case 1 to 146.5 MWh. The impact of natural gas delivery limit on the upward flexible ramping reserve is shown in Fig. 8. Because of the limit of gas delivery to unit G1, the upward flexible ramping reserve provided by G1 is decreased compared to case 1. Consequently, the participation of unit G2 in the flexible ramp market is increased which causes some increase in operating cost. Meanwhile, providing downward flexible ramping reserve by G1 does not require more fuel. Therefore natural gas delivery limit does not affect on the downward flexible ramping reserve of G1. The operation cost in case 2 has been increased to \$72732.95 which consist of \$69110.81 generation cost and \$3622.14 flexible ramping reserve cost.

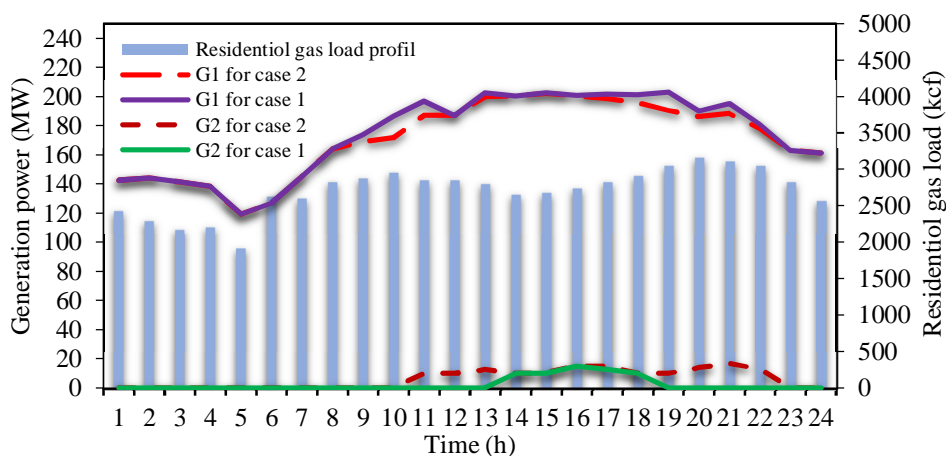

Fig. 7. Impact of natural gas delivery limit on hourly generation dispatch of units in case 2

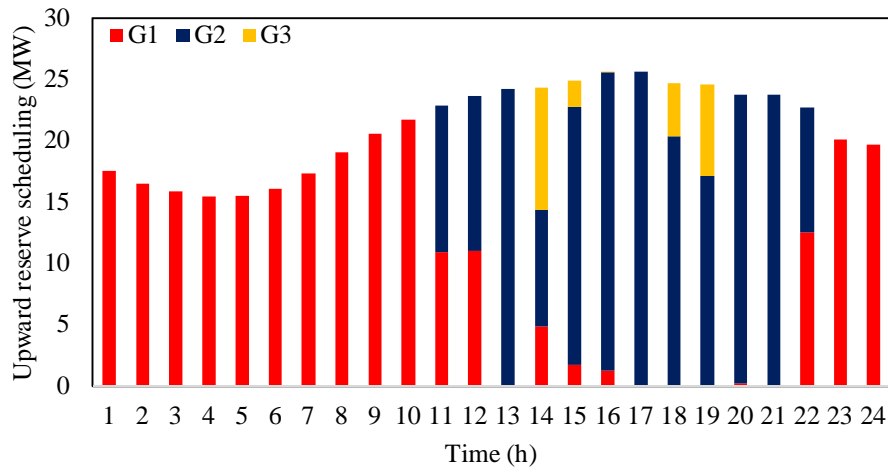

Fig. 8. Impact of natural gas delivery limit on upward flexible ramping reserve in case 2

Case 3: In this case, the impact of DR programs along with natural gas network constraints on system operation cost has been studied. DR is considered for all load buses with 10% load participation factor. Fig. 9 shows load profiles of the network after DR execution. In addition, hourly generation dispatch and upward flexible ramping reserve³³ provided by the power plants have been demonstrated in Figs. 10 and 11. Performing DR has shifted the load from peak-load hours to low-load hours which increases power dispatch of unit G1 at low-load hours in compared to case 2 and reduces total hourly dispatch (34% w.r.t case 2) and upward flexible ramping reserve (54% w.t.r. case 2) by unit G2. Also, the operation cost has been reduced to \$69602.86, which consist of \$66336.54 generation cost and \$3266.29 flexible ramping reserve cost.

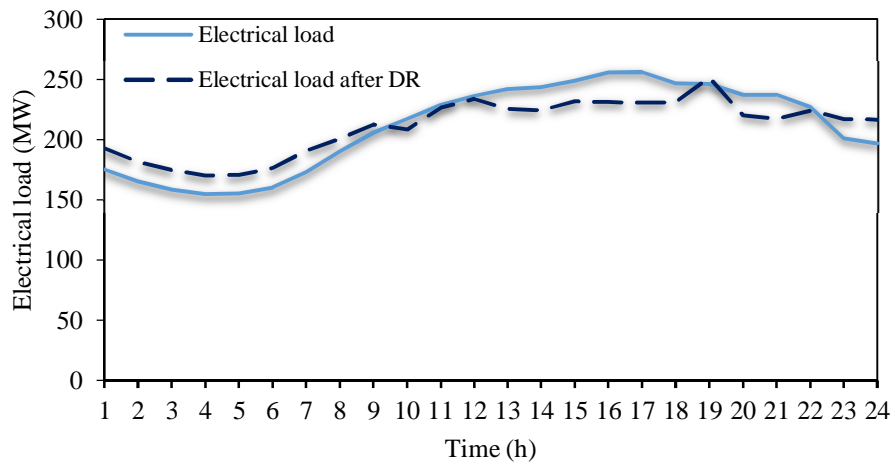

Fig. 9. Load profile of the network after DR execution in case 3

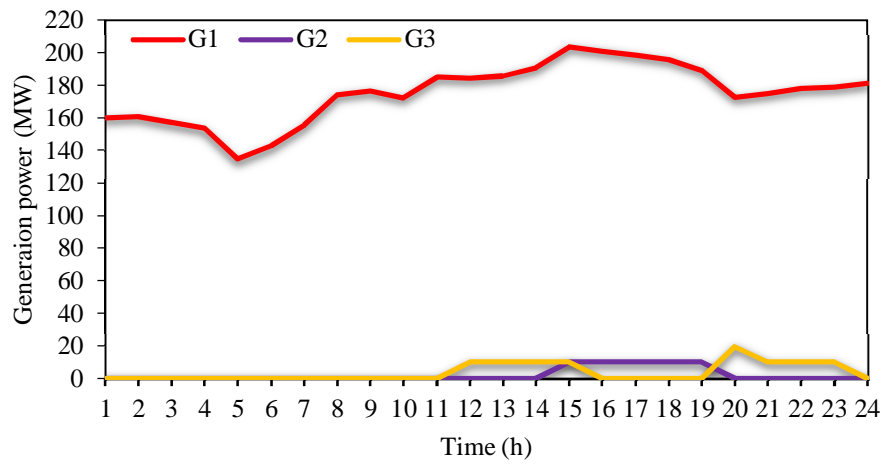

Fig. 10. Hourly generation dispatch of units in case 3

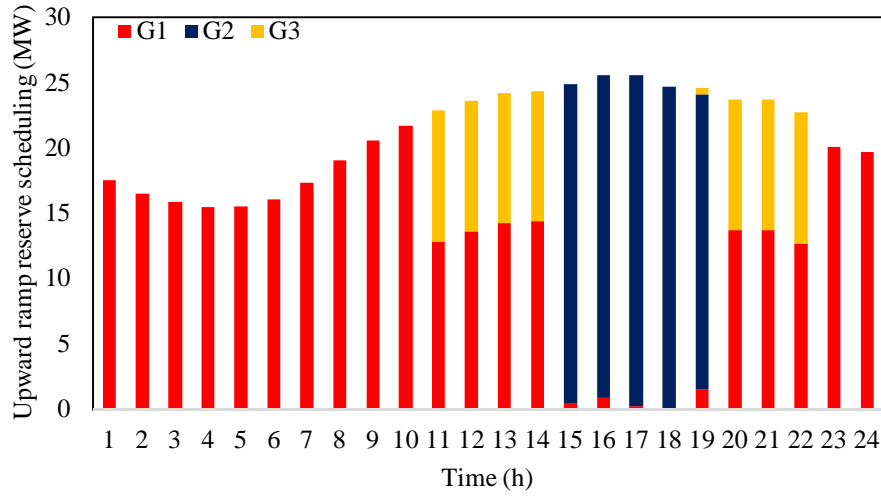

Fig. 11. Upward flexible ramping reserve provided by units in case 3

Case 4: In this case, the impact of CAES system on system operation cost is studied considering natural gas network constraints. CAES system data is given in Table 2. Figs. 12 and 13 show hourly generation of the units (G1, G2, and G3) and different operation modes (generation/compressor) of CAES system, respectively. In compressor mode, CAES stores excess power at low load hours and later on it delivers the stored energy to the network at peak load hours and hereby reduces the power dispatch of the most expensive unit G2. Also, as shown in Fig. 14 participation of CAES in flexible ramping reserve market provides most part of the upward and downward flexible ramping reserve. Operation cost in case 4 is \$69383.21 which consists of \$67681.59 generation cost and \$1701.62 flexible ramping reserve cost. The operation cost for the case that CAES system participates only in the energy market is increased to \$71719.09 which consists of \$68338.48 generation cost and \$3380.61 flexible ramping reserve cost.

Table 2. CAES system parameters

A_k^{max}	A_k^{min}	$P_{k,max}^d$	$P_{k,min}^d$	$P_{k,max}^c$	$P_{k,min}^c$
200	50	30	5	30	5

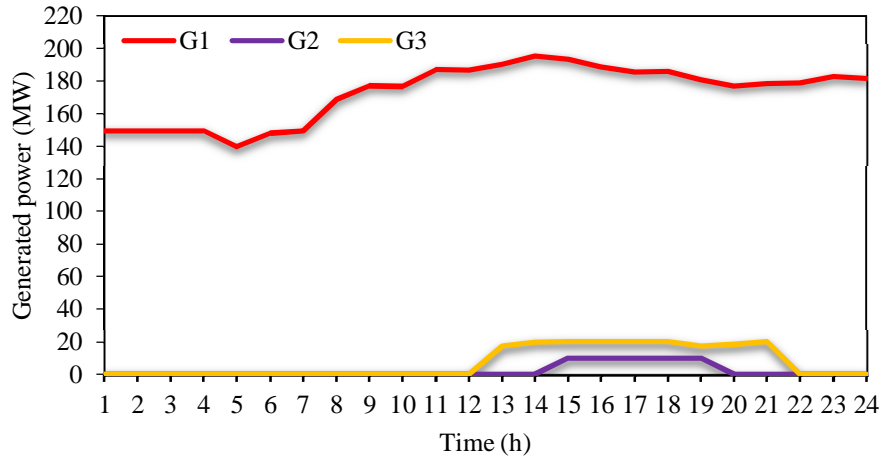

Fig. 12. Hourly generation dispatch of units in case 4

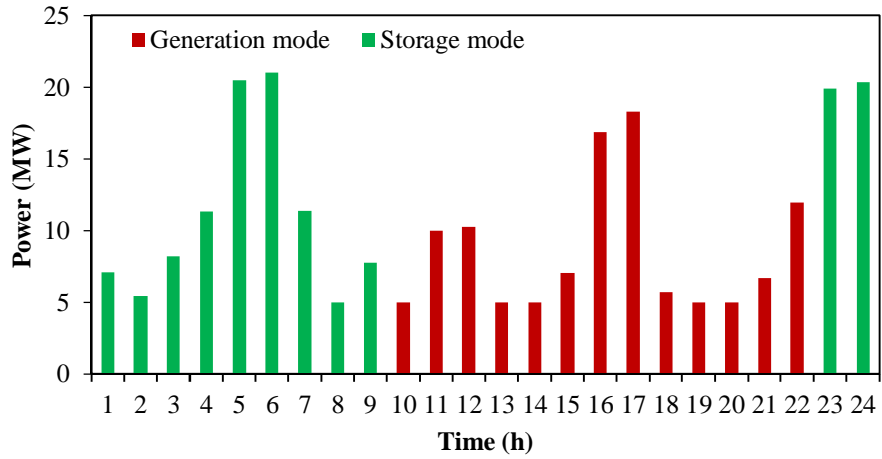

Fig. 13. Different operation modes of CAES system in case 4

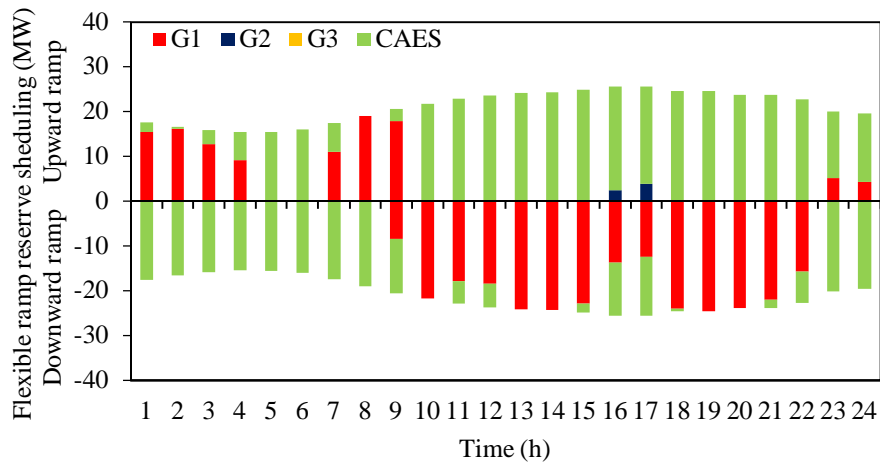

Fig. 14. Flexible ramping reserve scheduling in case 4

Case 5: In this case, emerging flexible resources such as DR program and CAES system are considered in system operation simultaneously. The impact of these resources on the hourly generation dispatch of the units is shown in Fig. 15. It is obvious that the most expensive unit G2 does not participate in generation dispatch and participation of G3 is limited only to hours 16 and 17, as a result, the operation cost of the system is reduced to \$66136.38. Table 3 demonstrates the comparison of generation cost and flexible ramp reserve cost for cases 2 to 5, as can be seen when emerging flexible sources are considered simultaneously, the total operation cost has more reduced.

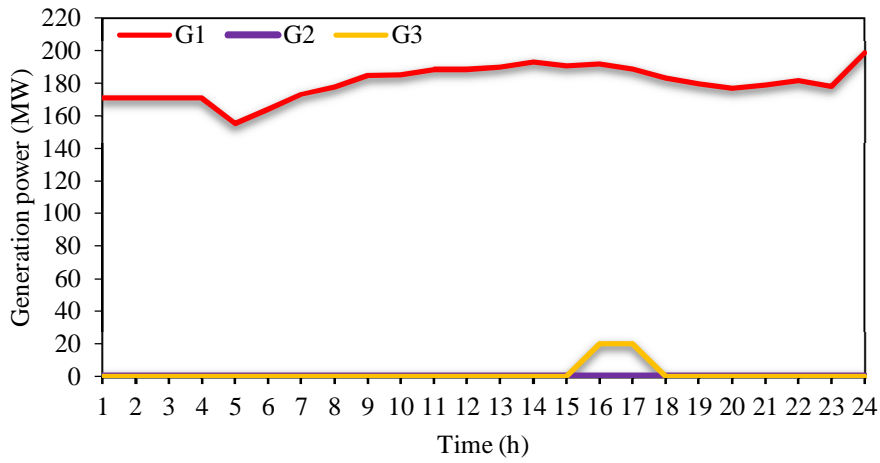

Fig. 15. Hourly generation dispatch of units in case 5

Table. 3. Comparison of production cost and flexible ramping reserve cost for cases 2-5 in 6-bus system

Case	2	3	4	5
Production cost (\$)	69110.81	66336.57	67681.59	64438.70
Flexible ramp reserve cost (\$)	3622.14	3266.29	1701.62	1697.68
Operation cost (\$)	72732.95	69602.86	69383.21	66136.38

Case 6: In this case, the IGDT-based robust method has been used to model wind uncertainty. Different operation strategies are evaluated for step-wise incremental values of robustness parameter β which varies from 0 to 0.06 with step size 0.01. The base value of operation cost (of_b) is considered the same as case 2 (\$72732.95). Fig. 16 demonstrates the schematic variation of optimum robustness function (α) with respect to β with and without emerging flexible resources. It is clear that increasing β can cause increasing critical operation cost, and α with and without emerging flexible resources. To be specific for $\beta=0.01$ and $\beta=0.04$, optimum robustness function without emerging flexible resources is 0.05 and 0.2, respectively. Therefore $\beta=0.04$ results in more region of robustness. As well, the optimum robustness function with emerging flexible resources has high value compared to the case of not considering emerging flexible resources. This implied even more region of robustness

against wind power prediction error and less impact of power generation uncertainty on system operation cost.

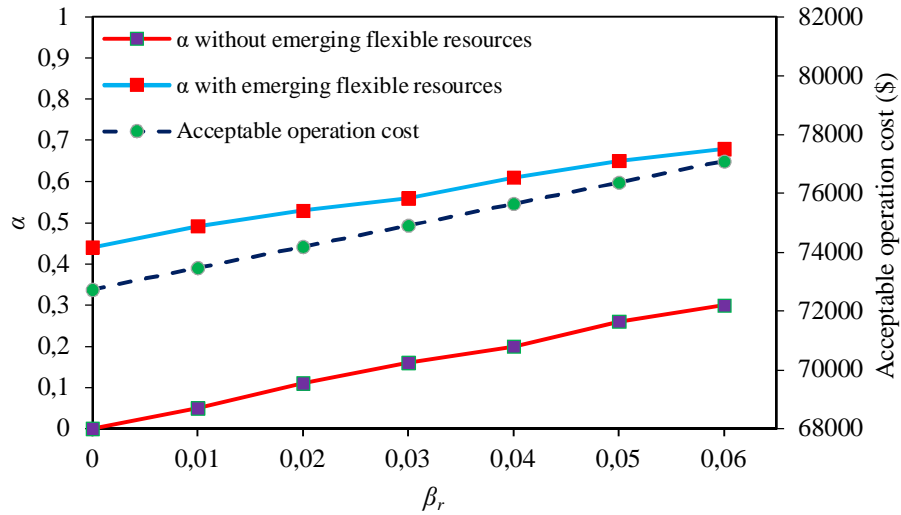

Fig. 16. Variation of optimum robustness function w.r.t β_r .

4.2 Modified IEEE-RTS 24 bus system

To evaluate the proposed model in a system with more realistic, we have considered modified IEEE Reliability 24-bus System that has 34 thermal units including 8 natural gas-fired units, 26 units of other types, 34 branches and 17 load buses. Two wind farms with a total capacity of 500 MW and two CAES units are located at buses 6 and 23. Network load profile, transmission line, and 26 generation units data are available in [47]. Also, the total generation capacity of 26 non-gas fire plants has been decreased by 10%. The 8 natural gas-fired units are sitting on buses 4, 6, 8, 10, 12, 15, 18 and 19. In addition, we have considered ten-node natural gas network consists of 10 pipelines, 14 natural gas loads (8 natural gas-fueled plants, 2 CAES system, and 4 residential natural gas loads). Natural gas system data are given in [20]. Upward and downward flexible ramping reserve cost provided by thermal plants is assumed 20% of their respective first-order coefficients. Also, upward

and downward flexible ramping reserve cost provided by CAES system is considered 20 % of its operating cost. The impact of natural gas network constraints and emerging flexible resources on total operation cost has been shown in Table 4. It is obvious that the inclusion of natural gas network constraints has increased the operating cost because of a shortage in gas delivery to natural gas-fueled plants and consequently increasing the generation dispatch of more expensive other type generation plants. Simultaneous integration of emerging flexible resources into the network has more reduced both daily operation cost and flexible reserve cost compared to the use of individual emerging flexible resource. For modeling the wind power uncertainty using IGDT-based robust method, different operation strategies have been considered based on the value of β varies from 0 to 0.04 with the step size of 0.01. The base case operation cost is assumed \$695093.67. Schematic variation of optimum robustness function with respect to β with and without emerging flexible resources is shown in Fig. 18. The results show that incrementing β can lead to an optimum increasing the optimal robustness function α with and without flexible resources. Also, as can be seen, when emerging flexible sources are considered simultaneously, expands the region of robustness for more wind power prediction error. As can be seen from results, the proposed model can be implemented in a realistic system and there is not any problem to solve the model. So, we can get the same results obtained from the 24-bus system in a more realistic system.

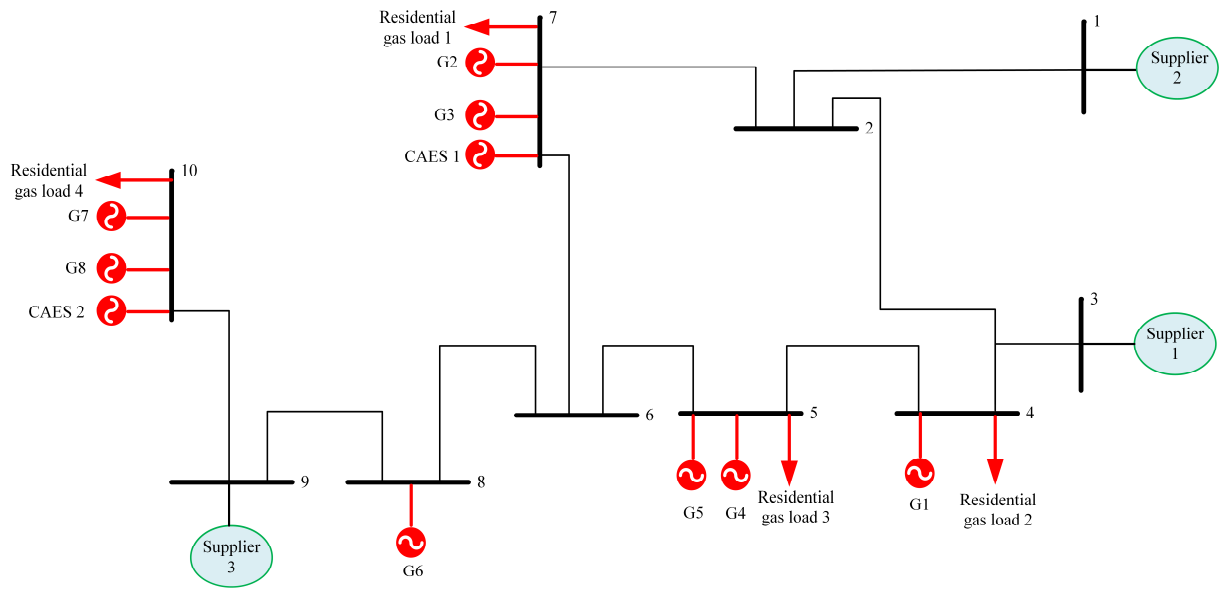

Fig. 17. Ten-node natural gas system

Table 4. Comparison of production cost & flexible ramping reserve cost for different cases in 24-bus system

Case studies	Without natural gas constraints	With natural gas constraints	DR included	CAES included	DR+CAES included
Production cost (\$)	654840.75	665506.35	645043.28	660447.97	641241.81
Flexible ramp reserve cost (\$)	28881.24	29587.31	28426.48	25379.34	24424.78
Total operation cost (\$)	683721.99	695093.67	673469.76	685827.31	665666.60

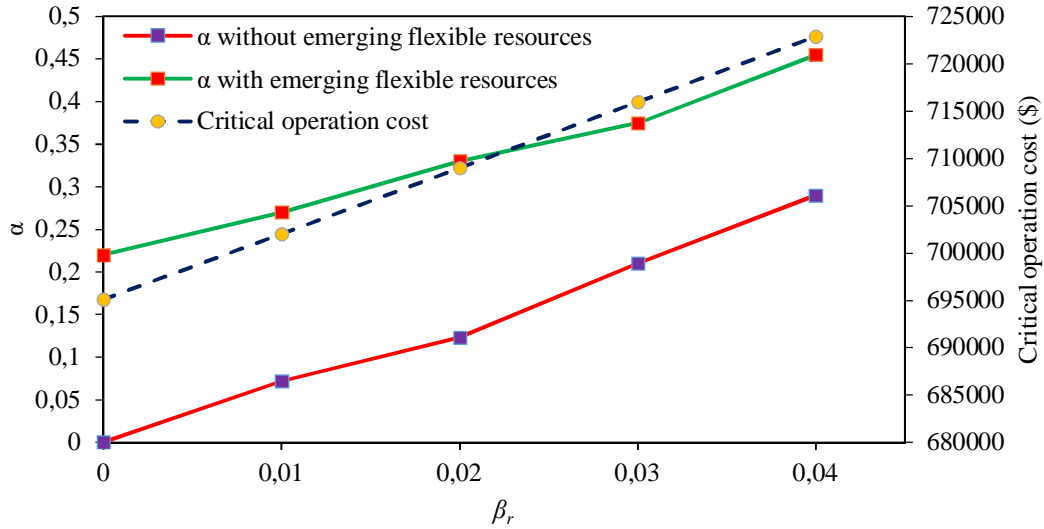

Fig. 18. Variation of optimum robustness function w.r.t β_r

5. Conclusion

In this paper was solved a robust SCUC problem for coordinated electricity and natural gas networks considering emerging flexible resources and flexible ramping products. Flexible ramping products were considered in order to ensure reliable power system operation there must be enough ramp capability to meet the variability of wind power in real-time dispatch stage. Also, the impact of natural gas network constraints on hourly generation dispatch, flexible ramp reserve provided by power plants, and power system operation cost was studied. Information gap decision theory (IGDT)-based robust approach was applied to manage wind power uncertainty with no need for PDF and fuzzy logic membership. This proposed method enables ISO to adjust the conservativeness of operation strategy by varying system operation cost. Also, the impact of emerging flexible resources such as CAES system and DR program on reducing the effect of natural gas constraints, wind power uncertainty, and total operating cost was studied and evaluated on two test systems. Simulation results showed that the integration of emerging

flexible resources in coordinated electricity and natural gas reduces the power system operation cost.

REFERENCES

- [1] He C, Zhang X, Liu T, Wu L, Shahidehpour M. Coordination of Interdependent Electricity Grid and Natural Gas Network—a Review. *Current Sustainable/Renewable Energy Reports*. 2018;5:23-36.
- [2] Melamed M, Ben-Tal A, Golany B. A multi-period unit commitment problem under a new hybrid uncertainty set for a renewable energy source. *Renewable Energy*. 2018;118:909-17.
- [3] Cui M, Zhang J. Estimating ramping requirements with solar-friendly flexible ramping product in multi-timescale power system operations. *Applied energy*. 2018;225:27-41.
- [4] Bjørndal E, Bjørndal M, Midthun K, Tomasgard A. Stochastic electricity dispatch: A challenge for market design. *Energy*. 2018;150:992-1005.
- [5] Lund PD, Lindgren J, Mikkola J, Salpakari J. Review of energy system flexibility measures to enable high levels of variable renewable electricity. *Renewable and Sustainable Energy Reviews*. 2015;45:785-807.
- [6] Chen Y, Hu M, Zhou Z. A data-driven analytical approach to enable optimal emerging technologies integration in the co-optimized electricity and ancillary service markets. *Energy*. 2017;122:613-26.
- [7] Rosales-Asensio E, de Simón-Martín M, Borge-Diez D, Blanes-Peiró JJ, Colmenar-Santos A. Microgrids with Energy Storage Systems as a Means to Increase Power Resilience: An Application to Office Buildings. *Energy*. 2019.
- [8] Alizadeh MI, Moghaddam MP, Amjady N. Multi-stage Multi-resolution Robust Unit Commitment with Non-deterministic Flexible Ramp Considering Load and Wind Variabilities. *IEEE Transactions on Sustainable Energy*. 2017.
- [9] Anand H, Narang N, Dhillon J. Unit commitment considering dual-mode combined heat and power generating units using integrated optimization technique. *Energy Conversion and Management*. 2018;171:984-1001.

- [10] Mirzaei MA, Yazdankhah AS, Mohammadi-Ivatloo B. Stochastic security-constrained operation of wind and hydrogen energy storage systems integrated with price-based demand response. *International Journal of Hydrogen Energy*. 2018.
- [11] Cornelius A. Assessing the impact of flexible ramp capability products in the Midcontinent ISO. Master's thesis, Duke University. 2014.
- [12] Navid N, Rosenwald G. Ramp capability for load following in the MISO markets Jul. 2011.
- [13] Heinen S, Hewicker C, Jenkins N, McCalley J, O'Malley M, Pasini S, et al. Unleashing the Flexibility of Gas: Innovating Gas Systems to Meet the Electricity System's Flexibility Requirements. *IEEE Power and Energy Magazine*. 2017;15:16-24.
- [14] Nojavan S, Najafi-Ghalelou A, Majidi M, Zare KJE. Optimal bidding and offering strategies of merchant compressed air energy storage in deregulated electricity market using robust optimization approach. 2018;142:250-7.
- [15] Daneshi H, Srivastava A. Security-constrained unit commitment with wind generation and compressed air energy storage. *IET Generation, Transmission & Distribution*. 2012;6:167-75.
- [16] Soares J, Ghazvini MAF, Borges N, Vale Z. A stochastic model for energy resources management considering demand response in smart grids. *Electric Power Systems Research*. 2017;143:599-610.
- [17] Liu C, Shahidehpour M, Fu Y, Li Z. Security-constrained unit commitment with natural gas transmission constraints. *IEEE Transactions on Power Systems*. 2009;24:1523-36.
- [18] Liu C, Shahidehpour M, Wang J. Coordinated scheduling of electricity and natural gas infrastructures with a transient model for natural gas flow. *Chaos: An Interdisciplinary Journal of Nonlinear Science*. 2011;21:025102.
- [19] Liu C, Shahidehpour M, Wang J. Application of augmented Lagrangian relaxation to coordinated scheduling of interdependent hydrothermal power and natural gas systems. *IET generation, transmission & distribution*. 2010;4:1314-25.
- [20] Alabdulwahab A, Abusorrah A, Zhang X, Shahidehpour M. Stochastic security-constrained scheduling of coordinated electricity and natural gas infrastructures. *IEEE Systems Journal*. 2015.

- [21] Wen Y, Qu X, Li W, Liu X, Ye X. Synergistic operation of electricity and natural gas networks via ADMM. *IEEE Transactions on Smart Grid*. 2017.
- [22] Alabdulwahab A, Abusorrah A, Zhang X, Shahidehpour MJIToSE. Coordination of interdependent natural gas and electricity infrastructures for firming the variability of wind energy in stochastic day-ahead scheduling. 2015;6:606-15.
- [23] Zhao B, Conejo AJ, Sioshansi R. Unit commitment under gas-supply uncertainty and gas-price variability. *IEEE Transactions on Power Systems*. 2017;32:2394-405.
- [24] He C, Liu T, Wu L, Shahidehpour MJJoMPS, Energy C. Robust coordination of interdependent electricity and natural gas systems in day-ahead scheduling for facilitating volatile renewable generations via power-to-gas technology. 2017;5:375.
- [25] He Y, Shahidehpour M, Li Z, Guo C, Zhu BJIToSE. Robust constrained operation of integrated electricity-natural gas system considering distributed natural gas storage. 2018;9:1061-71.
- [26] Chuan H, Tianqi L, Lei W, SHAHIDEHPOUR M. Robust coordination of interdependent electricity and natural gas systems in day-ahead scheduling for facilitating volatile renewable generations via power-to-gas technology. *Journal of Modern Power Systems and Clean Energy*. 2017;5:375-88.
- [27] Ordoudis C, Pinson P, Morales JMJEJoOR. An integrated market for electricity and natural gas systems with stochastic power producers. 2019;272:642-54.
- [28] He C, Wu L, Liu T, Wei W, Wang C. Co-optimization scheduling of interdependent power and gas systems with electricity and gas uncertainties. *Energy*. 2018;159:1003-15.
- [29] Aliasghari P, Zamani-Gargari M, Mohammadi-Ivatloo BJE. Look-ahead risk-constrained scheduling of wind power integrated system with compressed air energy storage (CAES) plant. 2018;160:668-77.
- [30] Ghaljehei M, Ahmadian A, Golkar MA, Amraee T, Elkamel A. Stochastic SCUC considering compressed air energy storage and wind power generation: A techno-economic approach with static voltage stability analysis. *International Journal of Electrical Power & Energy Systems*. 2018;100:489-507.

- [31] Zhang X, Shahidehpour M, Alabdulwahab A, Abusorrah AJIToPS. Hourly electricity demand response in the stochastic day-ahead scheduling of coordinated electricity and natural gas networks. 2016;31:592-601.
- [32] Kalavani F, Mohammadi-Ivatloo B, Zare K. Optimal stochastic scheduling of cryogenic energy storage with wind power in the presence of a demand response program. *Renewable Energy*. 2019;130:268-80.
- [33] Li G, Zhang R, Jiang T, Chen H, Bai L, Li X. Security-constrained bi-level economic dispatch model for integrated natural gas and electricity systems considering wind power and power-to-gas process. *Applied energy*. 2017;194:696-704.
- [34] Soltani Z, Ghaljehei M, Gharehpetian G, Aalami H. Integration of smart grid technologies in stochastic multi-objective unit commitment: An economic emission analysis. *International Journal of Electrical Power & Energy Systems*. 2018;100:565-90.
- [35] Heydarian-Forushani E, Golshan M, Siano P. Evaluating the benefits of coordinated emerging flexible resources in electricity markets. *Applied Energy*. 2017;199:142-54.
- [36] Wu H, Shahidehpour M, Khodayar ME. Hourly demand response in day-ahead scheduling considering generating unit ramping cost. *IEEE Transactions on Power Systems*. 2013;28:2446-54.
- [37] Wu H, Shahidehpour M, Alabdulwahab A, Abusorrah A. Thermal generation flexibility with ramping costs and hourly demand response in stochastic security-constrained scheduling of variable energy sources. *IEEE Transactions on Power Systems*. 2015;30:2955-64.
- [38] Wang B, Hobbs BF. A flexible ramping product: Can it help real-time dispatch markets approach the stochastic dispatch ideal? *Electric Power Systems Research*. 2014;109:128-40.
- [39] Zhang B, Kezunovic M. Impact on power system flexibility by electric vehicle participation in ramp market. *IEEE Transactions on Smart Grid*. 2016;7:1285-94.
- [40] Zhang X, Che L, Shahidehpour M, Alabdulwahab A, Abusorrah A. Electricity-natural gas operation planning with hourly demand response for deployment of flexible ramp. *IEEE Transactions on Sustainable Energy*. 2016;7:996-1004.

- [41] Heydarian-Forushani E, Golshan MEH, Shafie-khah M, Siano P. Optimal Operation of Emerging Flexible Resources Considering Sub-Hourly Flexible Ramp Product. *IEEE Transactions on Sustainable Energy*. 2018;9:916-29.
- [42] Mohammadi-Ivatloo B, Zareipour H, Amjady N, Ehsan M. Application of information-gap decision theory to risk-constrained self-scheduling of GenCos. *IEEE Transactions on Power Systems*. 2013;28:1093-102.
- [43] Soroudi A, Rabiee A, Keane A. Information gap decision theory approach to deal with wind power uncertainty in unit commitment. *Electric Power Systems Research*. 2017;145:137-48.
- [44] Chen K, Wu W, Zhang B, Sun H. Robust restoration decision-making model for distribution networks based on information gap decision theory. *IEEE Transactions on Smart Grid*. 2015;6:587-97.
- [45] Ahmadi A, Nezhad AE, Hredzak B. Security-Constrained Unit Commitment in Presence of Lithium-Ion Battery Storage Units using Information-Gap Decision Theory. *IEEE Transactions on Industrial Informatics*. 2018.
- [46] Nikoobakht A, Aghaei J. IGDT-based robust optimal utilisation of wind power generation using coordinated flexibility resources. *IET Renewable Power Generation*. 2016;11:264-77.
- [47] Force RT. The IEEE reliability test system-1996. *IEEE Trans Power Syst*. 1999;14:1010-20.