

# Experimental Wireless Wattmeter for Home Energy Management Systems

E.M.G. Rodrigues<sup>1</sup>, T. Caramelo<sup>1</sup>, T.D.P. Mendes<sup>1</sup>, R. Godina<sup>1</sup>,  
and J.P.S. Catalão<sup>1,2,3</sup>

<sup>1</sup>University of Beira Interior, Covilhã, Portugal, [catalao@ubi.pt](mailto:catalao@ubi.pt)

<sup>2</sup>INESC-ID, Lisbon, Portugal

<sup>3</sup>Instituto Superior Técnico, Lisbon, Portugal

**Abstract.** This paper presents a novel prototype device for domestic load energy consumption monitoring. Zigbee-based wireless connectivity is included as a basic feature of the prototype. The proposed device allows individual tracking of major energy consumption loads. Real time energy data is acquired and transmitted through a RF link to a wireless terminal unit, which works as a data logger and as a human-machine interface. Both voltage and current measurements are implemented using Hall Effect principle based transducers, while C code is developed on two 16-bit RISC MCU. The experimental setup is described and tests are conducted in order to assess its performance.

**Keywords:** Power meter, Zigbee, MSP430, sensors, cloud computing.

## 1 Introduction

A growing appetite for energy is a worldwide trend observable not only on industrialized countries as well as in emerging economies. Despite being a signal of economic vitality of modern society, concerns are rising among governments on how to match the energy needs in medium and long term without pushing hard natural resources exploitation or at the expense of public debt [1]. Different levels of human activities contribute with distinguishable energy-related footprints. A large share of the world energy demand is related to domestic consumption [2]. In fact, in the building sector up to 30% of consumed energy comes from residential loads, which are also responsible for 25% of demand during on-peak [3]. Refrigerators, space heating/cooling systems, water heaters, cloth washers, dryers, lighting, dishwashers, and cooking ranges in the residential sector are normally classified as major energy consumption devices [4]. In medium term, significant energy savings may occur in the residential sector towards today's electrical networks evolution into smart grids [5]. Home located advanced metering systems will also enhance this trend by giving residential users an unprecedented freedom to organize their domestic appliances daily usage [6]. In addition, other additional rationalization efforts can be promoted by taking advantage of available present technology.

In this context, a 2.4GHz ZigBee based distributed power metering system is proposed as part of a wireless home network area. This paper reports the development of an experimental wireless power meter device along with a wireless terminal unit to track and monitor individual energy consumption on domestic appliances. Practical development is supported on development boards equipped with microcontroller units. The power meter prototype is designed for electrical parameters measurement within AC low voltage systems. Energy related parameters calculations are root mean square (RMS) voltage or current, active and apparent power, along with load power factor.

This paper is organized as follows: Section 2 discusses the benefits of integrating home energy management services on a broad platform with cloud computing organization. Next, Section 3 presents the distributed metering system concept and unveils the wireless watt-meter prototype technical details, focusing on major engineering design steps. Afterwards, a set of experimental tests are analyzed on Section 4. Lastly, concluding remarks are made on Section 5.

## 2 Contribution to Cloud-based Engineering Systems

An Advanced Metering System (AMS) for home application relies on specialized meters designed for recording electricity and gas consumption periodically – smart meter. In turn, consumers will also access to monitors called In-Home Displays, which in turn allow them to see how much power is used at any time and how much it is costing them. The collected data will inspire consumers to use less energy, reducing their bills and supporting the environment. They will also be able to perceive when it is cheaper to run appliances [7]. The rising deployment of smart meters to people's homes outcomes in great quantities of data that required to be processed by power utilities. Cloud computing platforms can offer great scalability and availability concerning network bandwidth, computational resources, and storage. On the other hand, with the installation at large scale of distributed power meter devices for individualized energy consumption control purposes, an unprecedented increase of data generation arriving to smart meters is expected, which could in turn give rise to severe issues on the quality service provided by the communication infrastructure between the utility and consumers [8]. Cloud computing could alleviate smart grid agents' concerns and home owners' apprehension by providing additional dependable services. This means greater scalability and availability resources concerning network bandwidth, computational resources, and storage. Benefits of introducing two-way communications of the AMS/HAN based power meters with a cloud-based system are related to the information of the house's expected electricity usage behavior being concentrated and made available to a utility, load serving entity or an aggregator, and with those entities being able to execute their optimization processes by ensuring precise information to their consumers. Furthermore, the end-user could remotely access with a smartphone data regarding electricity consumption or even set parameters to the HAN connected domestic appliances in real-time. In addition, from the home owner standpoint, domestic informatics resources may not be adequate to store long term data. Finally, there is always a risk of losing it or been corrupted by a defective computer[9].

Figure 1 presents an overview for a global energy management paradigm through the cloud computing link. As can be seen, the cloud computing infrastructure performs a crucial interface acting as virtual decoupler between smart grid universe and home users, while at same time offering highly interoperability concerning communication capabilities.

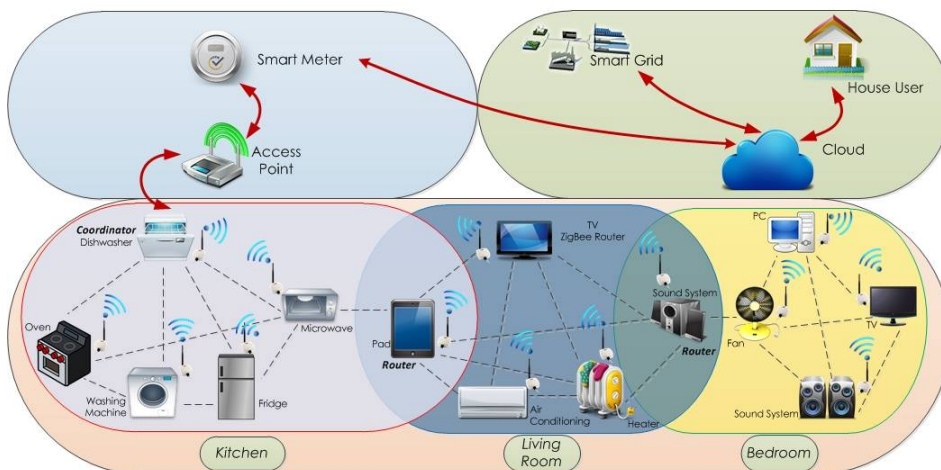

Fig.1. Cloud services interoperability with AMS/HAN based home energy management system.

## **3 Wireless Watt-Meter Prototype**

### **3.1 General diagram**

Figure 2 shows the minimum elements for the implementation of a home energy management system based on individual wireless metering systems. Three devices comprises the system: a smart meter, a metering unit that is in charge for the power and energy readings and a terminal unit prepared to receive real time energy consumption from each one of the domestic appliances plugged to a Zigbee network operated power meter. However, since a commercial smart meter is still expensive, the concept development and experimental tests have been conducted with the metering unit and terminal unit prototypes.

#### **a) MSP430F5438A and MSP430F5529**

Both models belong to MSP430 family of ultralow-power microcontrollers featuring a 16-bit RISC architecture. Major differences relay on flash and static ram memory, number of dedicated timer units, as well as serial bus interfaces (I2C, SPI and UART functionality) available. On the other hand, ADC specifications are exactly the same comprising a single module of 12-bit along with 16 channels (two are internally used) for conversion purposes. Sampling frequency is adjustable up to 200ksps in a single channel or in shared mode. For the metering unit, the MSP430F5438A MCU was chosen while the terminal unit was built on the MSP430F5529.

#### **b) CC2530 radio**

CC2530 radio is a mixed signal unit that comprises an IEEE 802.15.2 compliant RF transceiver along with an enhanced 8051 MCU supporting ZigBee, ZigBee PRO, and ZigBeeRF4CE standards. As the MCU side is equipped with up to 256kB of flash memory, 8kB RAM memory, including 2 USARTs, 12-Bit ADC, and 21 general-purpose GPIO. It is well suited to cover small home areas and enables robust and flexible operation due to mesh networking capabilities offered by the Zigbee protocol. Zigbee based wireless applications are gaining increasing acceptance for smart grid and for improving HAN's based AMS functionality [10], [11].

#### **c) ACS712 Current Sensor**

The Allegro ACS712 current sensor is based on the Hall-effect principle discovered by Edwin Hall. According to this principle, when a current carrying conductor is placed into a magnetic field, a voltage is generated across its edges perpendicular to the directions of both the current and the magnetic field. The sensor has the following main features: low noise analog signal, output sensitivity 66-185 mV/1A (+/-20 A), adjustable bandwidth up to 80 kHz and ratiometric linear output capability.

#### **d) LV 25-400 Voltage Sensor**

For voltage sensing the choice falls on the LV 25-400 voltage transducer manufactured by LEM. It is also based on Hall Effect physical principle. It allows maximum voltage RMS readings of 400V translated on reduced current mode output, allowing easy design of the analogue interface for instrumentation systems integration. It targets applications such as AC variable speed drives, servo-motor drives, DC motor drives static converters, as well as welding equipment's power supplies.

### **3.2 Design considerations and specifications**

Prototype implementation is followed by a functional block design approach, as can be seen in Figure 3.

#### **a) Scaling of analog signal levels**

Measures must also be appropriately handled to maximize metering system performance. Scaling is a set of procedures normally carried out to match physical signals with the ADC unit capabilities over its maximum conversion range.

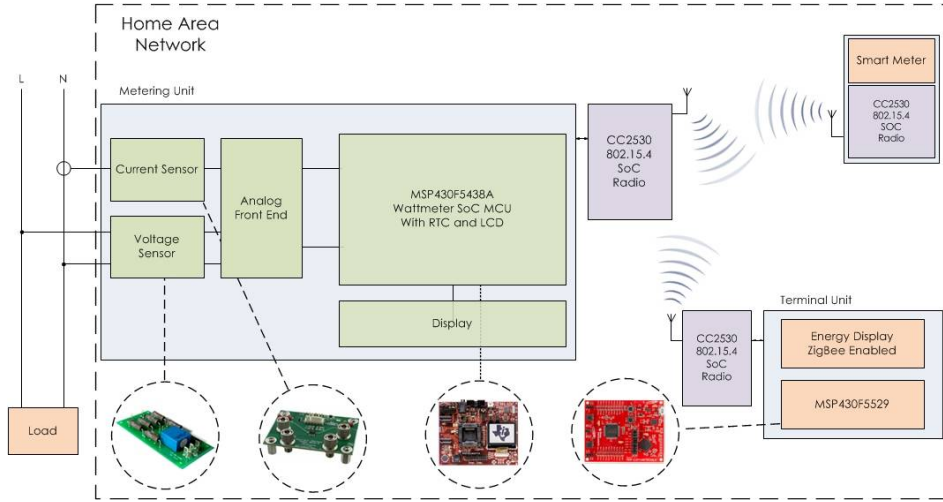

Fig.2. Wireless power meter and terminal unit block diagram.

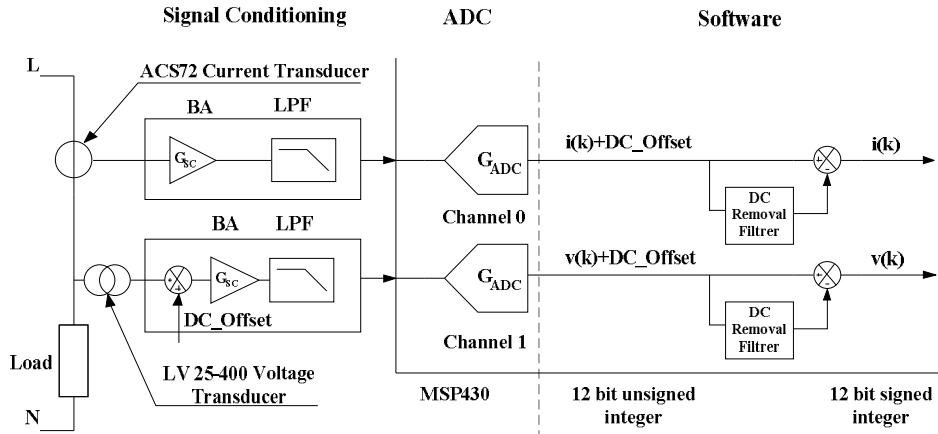

Fig.3. Sensing, acquisition and post-filtering block diagram.

Therefore, the signals before being acquired have to be scaled in the correct manner. Typically, real world signals are processed through an analog signal chain. ACS712 current sensor generates a unipolar voltage as output. The radiometric feature of the ACS712 means sensor gain and offsets are proportional to the supply voltage,  $V_{cc}$ . Thus, for 0 A load the sensor output is equal to  $V_{cc}/2$ , while sensitive range is proportional to its supply voltage. For the sake of simplicity, the ACS712 device is operated from a single power supply of 2.5 V that matches MSP430f5438A ADC internal voltage reference, which in turn reduces instrumentation chain complexity. The current transfer function is given by:

$$V_{IS} = K_{CT}I_{Load} + V_{OC} \quad (1)$$

where  $V_{IS}$  is the output voltage,  $K_{CT}$  is the gain coefficient of the transducer,  $I_{Load}$  is the sensed current and  $V_{OC}$  is the offset voltage related to the transducer zero current. Then, the ADC input voltage is expressed as:

$$V_{IS\_ADC} = K_{CS}(K_{CS}I_{Load} + V_{OC}) \quad (2)$$

where  $K_{CS}$  is the gain of the signal conditioning circuit.

The transfer function of the 12-bit ADC is represented by the equation:

$$N_{12\text{ bit}} = G_{ADC} V_{IS\_ADC} = \frac{2^{12}}{2.5} V_{IS\_ADC} \quad (3)$$

where  $N_{12\text{ bit}}$  is the 12-bit ADC code,  $G_{ADC}$  corresponds to the ADC equal to the ADC resolution divided by the input voltage range as indicated. The same formulation must be applied. Similar formulation can be applied to describe the instrumentation chain concerning grid voltage measurement. In digital power metering devices, the analog to digital converter unit has a key role on power meter performance. When it comes to commercial electricity metering equipment's most manufacturers opt for ADC's of 24-bit to digitize grid signals. The high level of quantization steps available is sufficient to guarantee an adequate resolution and precision in electrical measurements in order to fulfill international standards such as EN 50470-1:2006 or EN 50470-3:2006 [13]. However, the data acquisition capabilities available in the power meter prototype are modest in comparable terms. The MSP430f5438A has an internal ADC of lower word length configurable between 8-bit and 12-bit in steps of 2-bit. The resolution of the ADC determines the dynamic range of measured voltage and current. For voltage measurement, a maximum RMS reading of 300V is considered. Then, the voltage peak-to-peak range is given by:

$$U_{pk-to-pk} = 300 * \sqrt{2} * 2 = 848V \quad (4)$$

Considering that the accuracy of the MSP430f5438A's 12 bit ADC is  $\frac{1}{2^{12}}$ , which is equivalent to 0.02% of the full scale ADC range, theoretical resolution is respectively:

$$U_{LSB:peak\ to\ peak} = 848V * 0,0002 = 0.17V \quad (5)$$

$$U_{LSB:RMS} = 300V * 0,0002 = 0.06V \quad (6)$$

#### b) Antialiasing filter requirements

For digitizing analog samples the minimum sampling rate  $f_s$  must be more than twice the signal maximum frequency, according to Shannon's sampling theorem. On the contrary, if the rule is not respected the analog signal can't be fully reconstructed from the input samples, posing an undesired effect know as aliasing. In view of the MSP430f5438A is not tailored for signal processing-intensive calculations, a performance and accuracy trade-off was decided. Thus, for power measurements the acquired electric quantities should be limited with a harmonic content up to 20th order. In practical terms, the prototype bandwidth is 1000Hz concerning a fundamental grid frequency of 50Hz. Therefore, a low pass filter has been designed to limit voltage and current signals bandwidth. A Bessel filter was chosen due to its good amplitude and transient behavior performance. In addition, the filter's group delay is approximately constant across the entire pass-band, which is a mandatory design specification to limit distortion impacts on filtered signals. A cut-frequency of twice of the signal bandwidth specified can be observed from Bessel filter frequency response in Figure 4.

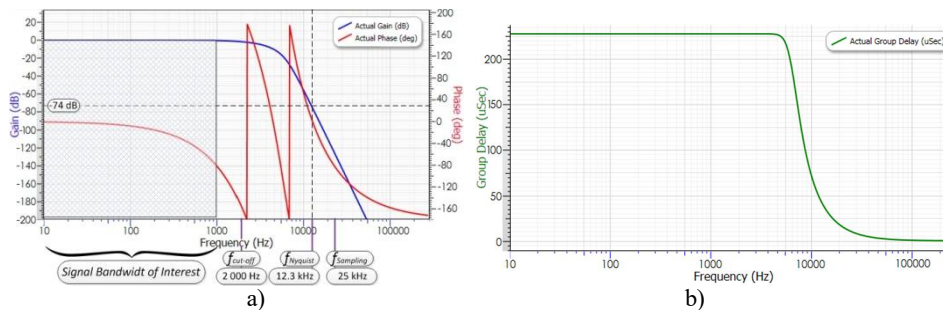

Fig.4. 10th order Bessel filter frequency response: a) Magnitude and phase; b) Group delay.

This is required to guarantee that the filter output attenuation at 1000Hz is virtually zero. High order Bessel filter and, consequently, higher sampling frequency selected have to do also with the ADC dynamic range, which in turn is related with its signal-to-noise ratio (SNR) [14]. For our study, it is assumed that the MSP430f5438A's 12-bit ADC is ideal. Hence, the SNR is 74 dB. Having this in mind, the Nyquist Frequency ( $f_s/2$ ) is approximately 12.3 kHz. In order to comply with Shannon's theorem, the sampling rate has been selected slightly above the minimum recommended.

### c) DC offset removal

Before moving to the energy transit related parameters calculation, the offset term must be eliminated from incoming signals. Instead of simply subtracting a fixed offset from the signals, a high pass filter was developed on Matlab. The first order IIR (Infinite Impulse Response) filter has a -3 dB cutoff frequency of 0.1Hz and sampling frequency of 25000s/sec.

The obtained digital filter can be expressed as:

$$y[n] = 0.996 * y[n - 1] + 0.996 * x[n] - 0.996 * x[n - 1] \quad (7)$$

Taking the z-transform of both sides and rearranging the terms, gives:

$$H(z) = \frac{0.996 - 0.996z^{-1}}{1 - 0.996z^{-1}} \quad (8)$$

To minimize the effects of binary word length on filter's outcome performance, especially when extracting the offset term on low voltage and current signals, filter's coefficients as well the result are handled in 32-bit arithmetic fixed point.

## 4 Experimental Tests and Results

A set of tests have been performed to verify the experimental watt-meter (Figure 5) implemented algorithms performance. For this purpose, a conventional electric heater has been chosen since it is a common domestic appliance. The domestic load offers two power regulation levels. The user can select between half and full power rated at 2000W. The tests focused on comparing current waveform acquisition by the device developed with the wave trace observed on an oscilloscope. In addition, a current clamp was employed to determine current RMS values at half and at full power. These measures made it possible to assess the prototype RMS estimation proximity to current clamp readings.

Figures 6 and 7 show that the current acquisition is relatively noisy; however, RMS estimation is not compromised.

In fact, on both load regimes the calculated values are very much in agreement within the current meter readings. Naturally the discrepancy found on prototype reading has to be confirmed with more tests covering a wider group of electric loads. This will be a future work of the authors. Moreover, a calibrated meter tool is mandatory to proceed to a metrological formal verification.

## 5 Conclusions

This paper presented a prototype device that allows individual tracking of major energy consumption loads. Energy data was acquired in real-time and transmitted through the RF link to a wireless terminal unit, which works as a data logger and as a human-machine interface. Both current and voltage measurements were executed using Hall Effect principle based transducers, while C code was developed and loaded on two 16-bit RISC MCU. The experimental assembly was described and a set of tests were carried out in order to validate the prototype developed.

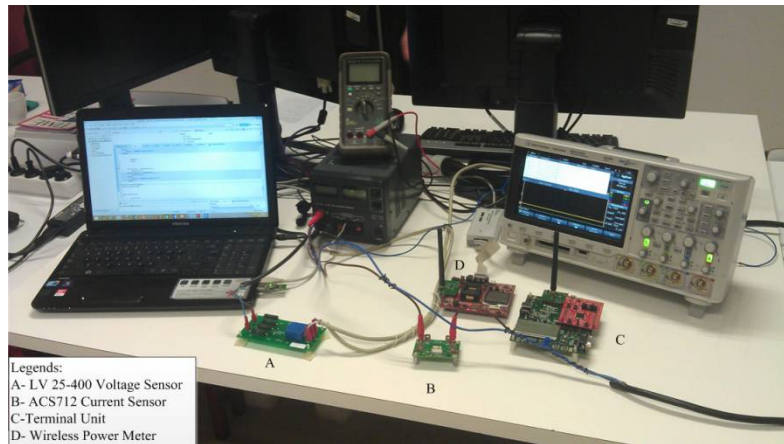

a)

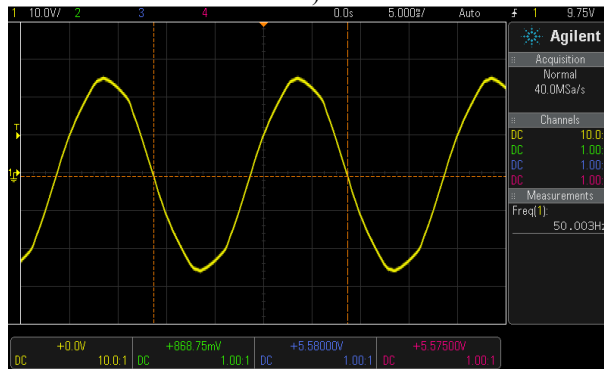

b)

Fig.5. a) General view of the experimental test bench; b) Grid voltage reading.

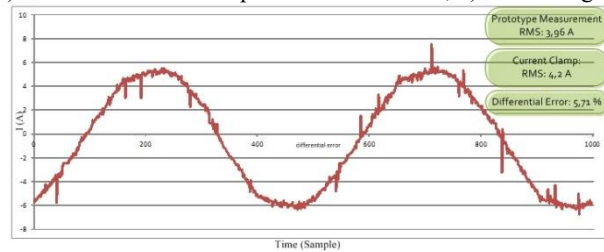

a)

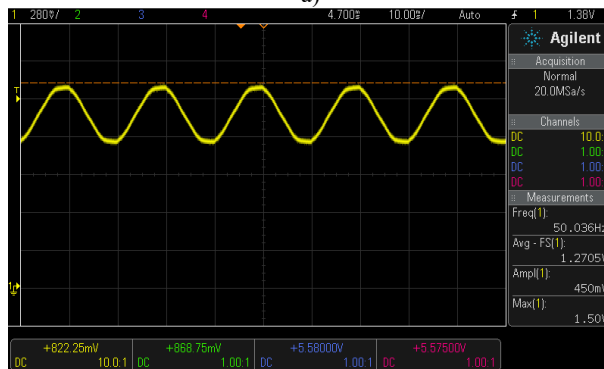

b)

Fig.6. Half power operating electric space heater:  
 a) Prototype acquired current profile; b) ACS712 output.

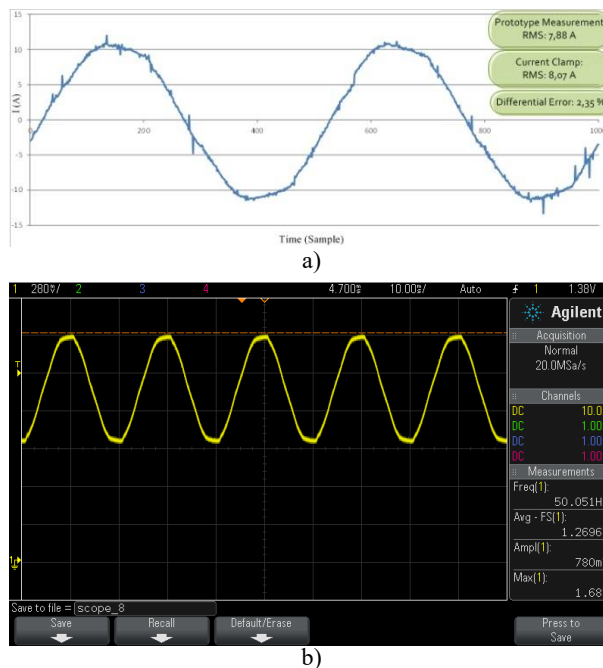

**Fig.7.** Full power operating electric space heater:  
a) Prototype acquired current profile; b) ACS712 output.

## Acknowledgment

This work was supported by FEDER funds (European Union) through COMPETE and by Portuguese funds through FCT, under Projects FCOMP-01-0124-FEDER-020282 (Ref. PTDC/EEA-EEL/118519/2010) and PEst-OE/EEI/LA0021/2013. Also, the research leading to these results has received funding from the EU Seventh Framework Programme FP7/2007-2013 under grant agreement no. 309048

## References

1. J. Byun, I. Hong, B. Kang and Sehyun Park, "A smart energy distribution and management system for renewable energy distribution and context-aware services based on user patterns and load forecasting," *IEEE Transactions on Consumer Electronics*, vol. 57, no. 2, pp. 436,444, 2011.
2. A. Nilsson et al., "Effects of continuous feedback on households' electricity consumption: Potentials and barriers," *Applied Energy*, vol. 122, pp. 17-23, 2014.
3. S. Tadokoro, Q.-S. Jia, Q. Zhao, H. Darabi, G. Huang, B. Becerik-Gerber, H. Sandberg and K. Johansson, "Smart Building Technology [TC Spotlight]," *IEEE Robotics & Automation Magazine*, vol. 21, no. 2, pp. 18-20, 2014.
4. M. Bozchalui, S. Hashmi, H. Hassen, C. Canizares and K. Bhattacharya, "Optimal Operation of Residential Energy Hubs in Smart Grids," *IEEE Transactions on Smart Grid*, vol. 3, no. 4, pp. 1755-1766, 2012.
5. G. Koutitas, "Control of Flexible Smart Devices in the Smart Grid," *IEEE Transactions on Smart Grid*, vol. 3, no. 3, pp. 1333-1343, 2012.
6. I. Georgievski, V. Degeler, G. Pagani, T. A. Nguyen, A. Lazovik and M. Aiello, "Optimizing Energy Costs for Offices Connected to the Smart Grid," *IEEE Transactions on Smart Grid*, vol. 3, no. 4, pp. 2273-2285, 2012.
7. M. Rahman, E. Al-Shaer and P. Bera, "A Noninvasive Threat Analyzer for Advanced Metering Infrastructure in Smart Grid," *IEEE Transactions on Smart Grid*, vol. 4, no. 1, pp. 273-287, 2013.
8. R. Green, L. Wang and M. Alam, "Applications and Trends of High Performance Computing for Electric Power Systems: Focusing on Smart Grid," *IEEE Transactions on Smart Grid*, vol. 4, no. 2, pp. 922-931, 2013.
9. X. Fang, S. Misra, G. Xue and D. Yang, "Managing smart grid information in the cloud: opportunities, model, and applications," *IEEE Network*, vol. 26, no. 4, pp. 32-38, 2012.
10. P. Kulkarni, T. Lewis and S. Dave, "Energy Monitoring in Residential Environments," *IEEE Technology and Society Magazine*, vol. 33, no. 3, pp. 71-80, 2014.
11. V. Nambodiri, V. Aravintan, S. Mohapatra, B. Karimi and W. Jewell, "Toward a Secure Wireless-Based Home Area Network for Metering in Smart Grids," *IEEE Systems Journal*, vol. 8, no. 2, pp. 509-520, 2014.
12. L. Li, Y. Chen, H. Zhou, H. Ma and J. Liu, "The application of hall sensors ACS712 in the protection circuit of controller for humanoid robots," in *2010 Int. Conf. Computer Application and System Modeling*, Taiyuan, 2010.
13. L. Holoubek, "Tauglich für das Smart Grid Elektrizitätszähler auf Basis eines Cortex-M4F-Mikrocontrollers," *Elektronik Industrie*, pp. 30-32, 2012.
14. A. Devices, "Fundamentals of Sampled Data Systems AN-282 Application Note," Norwood, Massachusetts.