

# Three-Level Hybrid Energy Storage Planning under Uncertainty

Reza Hemmati, Miadreza Shafie-khah, *Senior Member, IEEE*, and João P. S. Catalão, *Senior Member, IEEE*

**Abstract**—In conventional hybrid energy storage systems, two storage units complement each other. One low-capacity and fast-response unit as power supplier, and one high-capacity and low-response unit as an energy supplier. The power supplier mitigates fast fluctuations in generation or demand by transferring energy over seconds or minutes, and the energy supplier transfers energy over hours for managing energy. According to this concept, this paper presents a new model of hybrid energy storage systems, where three energy suppliers are considered as a three-level hybrid energy storage system. Energy storage at level 1 shifts energy from off-peak (or low-cost) hours to the on-peak (or high-cost) hours during one day, storage unit at level 2 transfers energy from off-peak (or low-cost) days to the on-peak (or high-cost) days for the period of one week, and level 3 transfers energy from off-peak seasons to the on-peak seasons through one year. The proposed planning results in a large-scale optimization programming that optimizes large numbers of design variables at the same time. In order to increase the flexibility of the planning, the initial energy of the storage units is also modelled as a design variable and optimized. The uncertainty of loads is modelled and a stochastic planning is carried out to solve the problem. The introduced three-level hybrid energy storage planning is simulated on two test systems, and the results demonstrate that the proposed planning can reduce the planning cost by about 1.8%.

**Index Terms**—Hybrid Energy Storage, Multi-Level, Stochastic Planning, Uncertainty.

## NOMENCLATURE

$A_c^h, A_c^d, A_c^s$	Coefficient for converting total cost of storage at levels 1, 2, 3 to the annual cost
$AC_E^h, AC_E^d, AC_E^s$	Annual investment cost on capacity of storage at levels 1, 2, 3 (\$/year)
$AC_P^h, AC_P^d, AC_P^s$	Annual investment cost on power of storage unit at levels 1, 2, 3 (\$/year)
$AC_O^h, AC_O^d, AC_O^s$	Annual operational cost of storage unit at levels 1, 2, 3 (\$/year)
$AC_{El}$	Annual cost of electricity (\$/year)
$B_c^h, B_c^d, B_c^s$	Binary variable showing charging of storage at levels 1, 2, 3

$B_d^h, B_d^d, B_d^s$	Binary variable showing discharging of storage at levels 1, 2, 3
$C_E^h, C_E^d, C_E^s$	Cost of capacity of storage unit at levels 1, 2, 3 (\$/p.u.)
$C_P^h, C_P^d, C_P^s$	Cost of power of storage unit at levels 1, 2, 3 (\$/p.u.)
$C_O^h, C_O^d, C_O^s$	Operational cost of storage unit at levels 1, 2, 3 (\$/p.u.)
$d$	Phase angle of bus voltage (Radian)
$dr$	Discount rate (%)
$E_0^h, E_0^d, E_0^s$	Initial energy of storage at levels 1, 2, 3 (p.u.)
$E_B^h, E_B^d, E_B^s$	Energy of storage at levels 1, 2, 3 (p.u.)
$Ef_h, Ef_d, Ef_s$	Efficiency of storage at levels 1, 2, 3 (%)
$E_{pr}$	Price of energy at each hour over the day (\$/kWh)
$E_r^h, E_r^d, E_r^s$	Rated capacity of storage unit at levels 1, 2, 3 (p.u.)
$F$	Flow through lines (p.u.)
$G, g$	Set of all generators, Index of generators
$Gn$	Set of generators installed on bus n
$k_{ld}, k_{pd}$	Daily load and price coefficients (%)
$k_{lh}$	Hourly load coefficient (%)
$k_{ls}, k_{ps}$	Seasonally load and price coefficients (%)
$LL$	Line capacity (p.u.)
$N$	Number of all buses in the network
$n, np$	Index of buses
$P_G^{Min}, P_G^{Max}$	Min. and max. capacity of generator (p.u.)
$P_r^h, P_r^d, P_r^s$	Rated power of storage at levels 1, 2, 3 (p.u.)
$P_c^h, P_c^d, P_c^s$	Charging power of storage at levels 1, 2, 3 (p.u.)
$P_d^h, P_d^d, P_d^s$	Discharging power of storage at levels 1, 2, 3 (p.u.)
$P_g, P_L$	Power of generator (p.u.), Base load (p.u.)
$S, s$	Set of all scenarios, Index of scenarios
$S_l, S_p$	Value of scenario (%), Probability of scenario
$Td, td$	Set of days in the week, Index of days
$Tdn$	Last day in the week
$Th, th$	Set of hours in the day, Index of hours
$Thn$	Last hour in the day
$Ts, ts$	Set of seasons in the year, Index of seasons
$Tsn$	Last season in the year
$T_{ws}$	Coefficient for converting weekly to seasonal cost
$x_l$	Reactance of the line (p.u.)
$yh, yd, ys$	Lifetime for storage at levels 1, 2, 3 (year)
$Z$	Objective function of the planning (\$/year)

## I. INTRODUCTION

ENERGY storage systems are useful technologies that have been widely developed and applied in electric power systems [1] as well as electric distributions networks [2]. The electric power systems mainly utilize bulk storage technologies such as pump-storage [3], compressed air [4], and bulk batteries [5].

J.P.S. Catalão acknowledges the support by FEDER funds through COMPETE 2020 and by Portuguese funds through FCT, under Projects SAICT-PAC/0004/2015 - POCI-01-0145-FEDER-016434, POCI-01-0145-FEDER-006961, UID/EEA/50014/2013, UID/CEC/50021/2013, and UID/EMS/00151/2013, and also funding from the EU 7th Framework Programme FP7/2007-2013 under GA no. 309048.

R. Hemmati is with the Department of Electrical Engineering, Kermanshah University of Technology, Kermanshah 63766-67178, Iran (e-mail: r.hemmati@kut.ac.ir).

M. Shafie-khah is with C-MAST, University of Beira Interior, Covilhã 6201-001, Portugal (e-mail: miadreza@ubi.pt).

J.P.S. Catalão is with INESC TEC and the Faculty of Engineering of the University of Porto, Porto 4200-465, Portugal, also with C-MAST, University of Beira Interior, Covilhã 6201-001, Portugal, and also with INESC-ID, Instituto Superior Técnico, University of Lisbon, Lisbon 1049-001, Portugal (e-mail: catalao@ubi.pt).

On the other hand, the electric distributions networks often install low capacity-power storage technologies such as small batteries [6]. The storage technologies are usually utilized for energy management [7] or power quality improvement [8]. In the energy management applications, high capacity and low-moderate response storage technologies such as batteries and pump-storage units are required. On the other hand, fast response and low-capacity units such as capacitors [9] and flywheel [10] are often applied for power quality enhancement.

Energy storage systems make significant impacts on the electric power systems and have been studied in power system expansion planning [11, 12], unit commitment [13], optimal power flow [14], economic dispatch [15], and power system control [16, 17].

Energy storage technologies are also utilized together with renewable energy resources in order to tackle their uncertainties [18]. Energy storage systems are mainly installed to damp out the fluctuations of wind [19], solar [20], and hybrid generation systems [21]. Hybrid energy storage systems are also one of the most efficient techniques to deal with renewable energy uncertainties [18]. Hybrid storage systems can be successfully utilized together with renewable energy resources for energy time shifting, renewable capacity firming, and renewable energy uncertainty smoothing [18]. Hybrid storage systems utilize two energy storage technologies at the same time as power supplier and energy supplier. Power supplier is high-power, low-capacity, fast-response, high life-cycle technology (such as supercapacitor) and energy supplier is a low-power, high-capacity, moderate-response, low life-cycle technology (such as batteries). Since there are different types of battery storage units, they can operate as both power supplier and energy supplier [18]. Different configurations of hybrid energy storage systems have been proposed by the researchers such as battery-supercapacitor, battery-supermagnetic, compressed air-flywheel, compressed air-battery, fuel cell-supercapacitor, and pump storage-battery [18].

Energy storage units are utilized to shift energy during one day hours. The current paper aims at addressing this drawback through proposing a multi-level storage planning. The current paper presents a new concept of hybrid energy storage system. In this method, three-level energy storage planning is proposed. In the introduced hybrid energy storage, three energy suppliers at three-level are installed and scheduled. The energy storage at level 1 shifts energy from off-peak hours to the on-peak hours during the day, the storage unit at level 2 transfers energy from off-peak days to the on-peak days during the week, and the unit in level 3 transfers energy from off-peak seasons to the on-peak seasons during the year.

As a result, charging-discharging cycles of the energy storages at levels 1, 2, and 3 are defined over one-day, one-week, and one-year, receptively.

It is worth mentioning that the proposed three-level planning may also be carried out through three sub-problems such that level 2 becomes a sub-problem for level 1 and level 3 is defined as a sub-problem for level 2. At such situation, the planning can solve level 1 and obtain the optimal storages at level 1, then it goes to the next level and finds the optimal storages and level 2 and eventually level 3. However, from the

mathematical point of view, solving all levels at the same time provides the optimal solution rather than solving each level separately. Modeling all three-level at the same time in one problem results in a very large-scale optimization programming and significantly increases the computational time, but on the other hand, it leads to the optimal solution for the problem.

All the time scales which can be considered in one year are day, week, month, and season. The daily operation shifts energy over the hours. The weekly and monthly operations shift energy over the days and the seasonally operation transfers energy over the seasons. As a result, the daily and seasonally operations are employed for levels 1 and 3. For level 2, the weekly or monthly must be utilized because both of them shift energy over the days. But, in the practical networks, the load profile follows weekly pattern and the monthly profile is often made based on the weekly profiles. As a result, the second level is made based on the weekly operation.

In summary, the novelties of the paper can be highlighted as follows:

- Introducing a coordinated three-level stochastic planning;
- Finding optimal power, capacity, and charging-discharging pattern for storage units at all levels;
- Considering the initial energy of energy storage units as a design variable and optimizing this parameter;
- Considering different strategy horizons in the same optimization problem;
- Employing a methodology for multiple storage systems.

Apart from this introductory part, the rest of the paper is organized as follows; Section II presents the mathematical formulation of the problem. Sections III introduces the test cases, and simulation results are given in section IV. Section V is devoted to the conclusions of the proposed methodology.

## II. PROBLEM FORMULATION

Figure 1 shows the overall structure of the proposed three-level ESS. The energy storage at level 1 has a daily operation, the storage unit at level 2 has a weekly operation, and the unit in level 3 has a seasonally operation. All the three-level units coordinate their operation with each other.

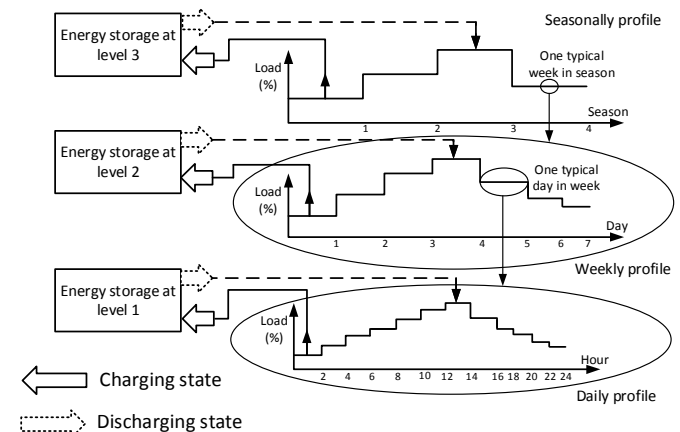

Fig. 1. Overall structure of three-level energy storage system

It is also proper to justify the feasibility of the suggested approach by following reasons; (i) Energy storage systems need a repetitive pattern for operation. The daily, weekly, and seasonally load profiles are the repetitive patterns in the realistic networks. As a result, the energy storage systems can be planned based on these time scales. (ii) Energy storage systems need a pattern including off-peak and on-peak stages for proper operation. The daily, weekly, and seasonally load profiles include off-peak and on-peak stages. As a result, the energy storage systems can be appropriately scheduled based on these time scales.

### A. Objective function of the problem

The proposed problem aims at minimizing total energy cost paid by consumers at load points. The objective function of the problem is defined by (1) in which the total cost is minimized.

$$\text{Min } \left\{ Z = AC_{El} + AC_P^h + AC_E^h + AC_O^h + AC_P^d + AC_E^d + AC_O^d + AC_P^s + AC_E^s + AC_O^s \right\} \quad (1)$$

The objective function (1) comprises 10 parts. The first part of the objective function (i.e.,  $AC_{El}$ ) shows the total cost of energy paid by consumers at load points during one year. This cost is optimized by optimal installing (i.e., planning) and charging-discharging (i.e., scheduling) of three-level energy storage units. Also, the cost is presented as the expected value of cost under all scenarios related to the load uncertainty.

$$AC_{El} = \sum_{s \in S} \sum_{n \in N} \sum_{ts \in Ts} \sum_{td \in Td} \sum_{th \in Th} \left\{ \left[ (P_L(n) \times S_l(s) \times k_{lh}(th) \times k_{ld}(td) \times k_{ls}(ts) + P_c^h(n, th) - P_d^h(n, th) + P_c^d(n, td, th) - P_d^d(n, td, th) + P_c^s(n, ts, td, th) - P_d^s(n, ts, td, th)) \times k_{pd}(td) \times k_{ps}(ts) \times E_{pr}(th) \times T_{ws} \right] \times S_p(s) \right\} \quad (2)$$

The second to fourth terms of (1) indicate the investment and operational costs of energy storage unit at level 1. Where, the investment cost of power, the investment cost of capacity, and the operational cost for energy storage unit at level 1 are given by (3) to (5), respectively.

$$AC_P^h = \sum_{n \in N} \left[ P_r^h(n) \right] \times C_P^h \times A_c^h \quad (3)$$

$$AC_E^h = \sum_{n \in N} \left[ E_r^h(n) \right] \times C_E^h \times A_c^h \quad (4)$$

$$AC_O^h = \sum_{n \in N} \left[ E_r^h(n) \right] \times C_O^h \times 365 \quad (5)$$

The fifth to seventh terms of (1) specify the investment cost of power, the investment cost of capacity, and the operational cost for energy storage unit at level 2 and they are defined by (6) to (8), respectively.

$$AC_P^d = \sum_{n \in N} \left[ P_r^d(n) \right] \times C_P^d \times A_c^d \quad (6)$$

$$AC_E^d = \sum_{n \in N} \left[ E_r^d(n) \right] \times C_E^d \times A_c^d \quad (7)$$

$$AC_O^d = \sum_{n \in N} \left[ E_r^d(n) \right] \times C_O^d \times 365 \quad (8)$$

Eventually, the final three terms of (1) represent the investment and operational costs of energy storage unit at level 3, and these costs are defined through (9) to (11).

$$AC_P^s = \sum_{n \in N} \left[ P_r^s(n) \right] \times C_P^s \times A_c^s \quad (9)$$

$$AC_E^s = \sum_{n \in N} \left[ E_r^s(n) \right] \times C_E^s \times A_c^s \quad (10)$$

$$AC_O^s = \sum_{n \in N} \left[ E_r^s(n) \right] \times C_O^s \times 365 \quad (11)$$

The total investment costs related to all energy storage units are converted to the equivalent annual cost by relationships defined through (12) to (14). Also, all daily operational costs are elaborated over the year to calculate the annual cost.

$$A_c^h = \left( dr \times (1 + dr)^{yh} \right) / \left( (1 + dr)^{yh} - 1 \right) \quad (12)$$

$$A_c^d = \left( dr \times (1 + dr)^{yd} \right) / \left( (1 + dr)^{yd} - 1 \right) \quad (13)$$

$$A_c^s = \left( dr \times (1 + dr)^{ys} \right) / \left( (1 + dr)^{ys} - 1 \right) \quad (14)$$

### B. Energy storage unit at level 1

The energy storage at level 1 transfers energy from off-peak hours to on-peak hours during every day. Operation of energy storage at level 1 is defined by following relationships. Constraints (15) to (17) show that storage unit can operate only on charging state or on discharging state at each hour. The charged and discharged powers are limited by the rated power of the unit. Constraint (18) presents the equilibrium of energy over all hours of the day. Constraint (19) indicates the energy status over day hours. The initial energy of unit is defined by (20), and the rated capacity is given by (21).

$$B_c^h(n, th) + B_d^h(n, th) \leq 1 \quad \forall n \in N, th \in Th \quad (15)$$

$$P_c^h(n, th) \leq B_c^h(n, th) \times P_r^h(n) \quad \forall n \in N, th \in Th \quad (16)$$

$$P_d^h(n, th) \leq B_d^h(n, th) \times P_r^h(n) \quad \forall n \in N, th \in Th \quad (17)$$

$$\sum_{th \in Th} \left( Ef_h \times P_c^h(n, th) - P_d^h(n, th) \right) = 0 \quad \forall n \in N \quad (18)$$

$$E_B^h(n, th) = E_B^h(n, th - 1) + P_c^h(n, th) - \left( P_d^h(n, th) / Ef_h \right) \quad \forall n \in N, th \in Th \quad (19)$$

$$E_B^h(n, Thn) = E_0^h(n) \quad \forall n \in N \quad (20)$$

$$E_B^h(n, th) \leq E_r^h(n) \quad \forall n \in N, th \in Th \quad (21)$$

Constraint (20) limits the storage flexibility because it limits the initial and final states of charge (SOC). If the initial and final SOC are allowed to be different, the mathematical optimization will be better. But different initial and final SOC results in different optimal charging-discharging patterns for each day over the planning horizon. Both models can be considered in the planning. However, this paper employs the first model.

### C. Energy storage unit at level 2

The storage unit at level 2 transfers energy from one day to the other days during one week. Operation of this unit is defined through (22) to (28). Constraints (22) to (24) represents that the storage unit can operate only on charging state or discharging state at each day. The planning not only determines the optimal days for charging-discharging of energy storage, but also it indicates the optimal hours at each day for charging-discharging of the storage unit at level 2. The charged and discharged powers are also limited by the rated power. The equilibrium of energy at all hours is confirmed by (25). Constraint (26) shows the energy of storage unit at each hour of each day during one week. The initial energy and rated capacity of unit are defined by (27) and (28).

$$B_c^d(n, td) + B_d^d(n, td) \leq 1 \quad \forall n \in N, td \in Td \quad (22)$$

$$P_c^d(n, td, th) \leq B_c^d(n, td) \times P_r^d(n) \quad (23)$$

$$\forall n \in N, th \in Th, td \in Td$$

$$P_d^d(n, td, th) \leq B_d^d(n, td) \times P_r^d(n) \quad (24)$$

$$\forall n \in N, th \in Th, td \in Td$$

$$\sum_{td \in Td} \sum_{th \in Th} (Ef_d \times P_c^d(n, td, th) - P_d^d(n, td, th)) = 0 \quad (25)$$

$$\forall n \in N$$

$$E_B^d(n, td, th) = E_B^d(n, td, th - 1) + P_c^d(n, td, th) - (P_d^d(n, td, th) / Ef_d) \quad \forall n \in N, th \in Th, td \in Td \quad (26)$$

$$E_B^d(n, Tdn, Thn) = E_0^d(n) \quad \forall n \in N \quad (27)$$

$$E_B^d(n, td, th) \leq E_r^d(n) \quad \forall n \in N, th \in Th, td \in Td \quad (28)$$

### D. Energy storage unit at level 3

The storage unit at level 3 alters energy between seasons of one year. This unit is modelled by (29) to (35). As shown through (29) to (31), this unit can only operate on charging state or discharging state at each season as well as the rated power limits the charging and discharging powers. The proposed formulation not only determines the optimal seasons for charging-discharging of the unit at level 3, but also indicates the optimal days and hours for operation. The equilibrium of energy at all hours over one year is shown by (32). The energy of storage at each hour over the year is calculated by (33). The initial energy of storage unit is defined by (34), and its rated capacity is modelled by (35).

$$B_c^s(n, ts) + B_d^s(n, ts) \leq 1 \quad \forall n \in N, ts \in Ts \quad (29)$$

$$P_c^s(n, ts, td, th) = B_c^s(n, ts) \times P_r^s(n) \quad (30)$$

$$\forall n \in N, th \in Th, td \in Td, ts \in Ts$$

$$P_d^s(n, ts, td, th) = B_d^s(n, ts) \times P_r^s(n) \quad (31)$$

$$\forall n \in N, th \in Th, td \in Td, ts \in Ts$$

$$\sum_{ts \in Ts} \sum_{td \in Td} \sum_{th \in Th} \{Ef_s \times P_c^s(n, ts, td, th) - P_d^s(n, ts, td, th)\} = 0 \quad \forall n \in N \quad (32)$$

$$E_B^s(n, ts, td, th) = E_B^s(n, ts, td, th - 1) + P_c^s(n, ts, td, th) - (P_d^s(n, ts, td, th) / Ef_s) \quad (33)$$

$$\forall n \in N, th \in Th, td \in Td, ts \in Ts$$

$$E_B^s(n, Tsn, Tdn, Thn) = E_0^s(n) \quad \forall n \in N \quad (34)$$

$$E_B^s(n, ts, td, th) \leq E_r^s(n) \quad (35)$$

$$\forall n \in N, th \in Th, td \in Td, ts \in Ts$$

### E. Security constraints of the network

The security constraints of the network are given through (36) to (40). Flow through each transmission line is calculated by (36). The capacity of the lines is limited by (37), and the capacity of the generators is limited by (38) and (39). The equilibrium of power at each bus of the network is confirmed by (40).

$$F(s, n, np, ts, td, th) = \{d(mcs, n, ts, td, th) - d(mcs, np, ts, td, th)\} / x_l(n, np) \quad (36)$$

$$\forall s \in S, n \in N, np \in N, ts \in Ts, td \in Td, th \in Th$$

$$|F(s, n, np, ts, td, th)| \leq LL(n, np) \quad (37)$$

$$\forall s \in S, n \in N, np \in N, ts \in Ts, td \in Td, th \in Th$$

$$P_g(s, g, ts, td, th) \leq P_G^{Max}(g) \quad (38)$$

$$\forall s \in S, g \in G, ts \in Ts, td \in Td, th \in Th$$

$$P_g(s, g, ts, td, th) \geq P_G^{Min}(g) \quad (39)$$

$$\forall s \in S, g \in G, ts \in Ts, td \in Td, th \in Th$$

$$\sum_{g \in Gn} P_g(s, g, ts, td, th) - \sum_{np \in N} F(s, n, np, ts, td, th) =$$

$$P_L(n) \times S_l(s) \times k_{lh}(th) \times k_{ld}(td) \times k_{ls}(ts) + P_c^h(n, th) - P_d^h(n, th) + P_c^d(n, td, th) -$$

$$P_d^d(n, td, th) + P_c^s(n, ts, td, th) - P_d^s(n, ts, td, th)$$

$$\forall s \in S, n \in N, ts \in Ts, td \in Td, th \in Th$$

### F. Design variables of the problem

In order to provide more details about the proposed mathematical formulation, the design variables of the proposed three-level storage planning are listed in Table I. The introduced planning finds the optimal rated power, rated capacity, charging-discharging pattern, and the initial energy of energy storage units at levels 1, 2, and 3 at the same time.

Also, the network parameters such as power of generators, flows in transmission lines, and phase angle of the bus voltages are modelled as design variables and optimized.

The design variables related to the network are also associated with the scenarios related to the load uncertainty and the stochastic planning is realized to tackle the uncertainties. On the other hand, the design variables related to the energy storage units are not associated with the scenarios related to the load uncertainty. This issue means that the designed energy storage units can successfully operate under all scenarios related to the load uncertainty.

In other words, the proposed planning is robust for the considered set of scenarios.

### G. Framework of the problem

In order to provide more details, the framework of the proposed planning is depicted on the flowchart of Fig. 2. The details about the coordination of three-level planning and procedure of the solution can be found in this flowchart.

Variables related to the network	$d(s, n, ts, td, th); F(s, n, np, ts, td, th); P_g(s, g, ts, td, th)$
Variables related to the storage unit at level 1	$E_B^h(n, th); E_0^h(n); P_c^h(n, th); P_d^h(n, th); P_r^h(n); E_r^h(n); B_c^h(n, th); B_d^h(n, th)$
Variables related to the storage unit at level 2	$E_B^d(n, td, th); P_c^d(n, td, th); P_d^d(n, td, th); P_r^d(n); E_r^d(n); B_c^d(n, td); B_d^d(n, td); E_0^d(n)$
Variables related to the storage unit at level 3	$E_B^s(n, ts, td, th); E_0^s(n); P_c^s(n, ts, td, th); P_d^s(n, ts, td, th); P_r^s(n); E_r^s(n); B_c^s(n, ts); B_d^s(n, ts)$

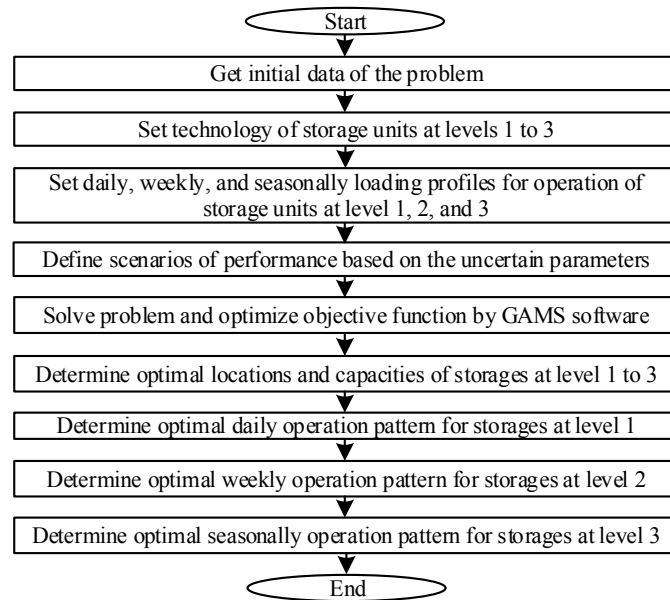

Fig. 2. Framework of the proposed methodology

### III. STOCHASTIC MODEL DESCRIPTION

The stochastic model provided by this paper is based on the scenario-generation and scenario-reduction techniques [22].

In this technique, first, the continuous distribution functions are modelled and characterizes by equivalent discrete distribution functions. Then, the process of scenario generation is performed by operating the roulette wheel mechanism. All the uncertain parameters of the problem are individually analyzed to calculate their percentage of errors and occurrence probabilities. Then the scenarios are formed by random sampling from the uncertain parameters. Also, the probability of each scenario is calculated as the multiplication of all the calculated probabilities of the uncertain parameters.

This procedure is repeated until the desirable number of the scenarios is achieved. Then, a scenario reduction technique is carried out to reduce number of the scenarios. In this paper, the backward scenario reduction technique is utilized to reduce number of scenarios and computational burden [22].

### IV. TEST NETWORKS

Two test systems are considered to simulate the proposed planning. Rated power for both cases is 100 MVA, and the discount rate is equal to 5 percent.

The first test system is a 3-bus network, and its data are listed in Tables II and III. This network is a modified version of the network presented in [23].

The second test system is IEEE 24-bus network, and its data can be found in [24]. Data of load levels for both cases are listed in Tables IV to VI.

Network 2 comprises 33 generators and the optimal operation for all of them is determined by the panning.

The prices are taken as the average of actual prices [25]. The energy storage units at levels 1, 2, and 3 are introduced in Table VII [26].

In Table VII, life-time of units is presented subject to their charging-discharging cycle. The unit at level 1 has a daily operational cycle, level 2 has a weekly operational cycle, and level 3 has an annual operational cycle. As a result, lifetime of units at levels 2 and 3 will be increased.

TABLE II. BUS DATA OF TEST SYSTEM 1

	PGMin (p.u.)	PGMax (p.u.)	Load (p.u.)
Bus 1	0.20	2.50	0.00
Bus 2	0.00	0.00	4.00
Bus 3	0.20	2.50	0.00

TABLE III. LINE DATA OF TEST SYSTEM 1

From	To	X (p.u.)	Capacity (p.u.)
Bus 1	Bus 2	0.0200	2.5
Bus 1	Bus 3	0.0100	2.5
Bus 2	Bus 3	0.0125	3.5

TABLE IV. LOAD DATA FOR HOURLY PROFILE

Hour	Load level (%)	Price (\$/kWh)
1	0.7370	0.0800
2	0.6930	0.0800
3	0.6600	0.0800
4,5	0.6490	0.0800
6	0.6600	0.0800
7	0.8140	0.0800
8	0.9460	0.0800
9	1.0450	0.2200
10-11	1.0560	0.2200
12-14	1.0450	0.2200
15-16	1.0230	0.2200
17	1.0890	0.2200
18	1.1000	0.2200
19	1.1000	0.1400
20	1.0560	0.1400
21	1.0010	0.1400
22	0.9130	0.1400
23	0.8030	0.1400
24	0.6930	0.1400

TABLE V. LOAD DATA FOR WEEKLY PROFILE

Day	1	2	3	4	5	6	7
Load level (%)	0.90	0.95	1.00	0.95	0.88	0.80	0.90
Price (%)	1.10	1.15	1.25	1.15	1.08	1.00	1.10

TABLE VI. LOAD DATA FOR SEASONALLY PROFILE

Season	1	2	3	4
Load level (%)	0.90	0.93	1.02	0.96
Price (%)	1.00	1.02	1.09	1.04

TABLE VII. DATA OF ENERGY STORAGE UNITS AT LEVELS 1, 2, AND 3

	storage at level 1 (Li-ion battery)	storage at level 2 (lead-acid battery)	storage at level 3 (pump storage)
Cost of power (\$/kW)	230	280	330
Cost of capacity (\$/kWh)	180	180	15
Operational cost (\$/kWh-day)	0.5e-3	0.6e-3	0.6e-3
Life time (year)	5	17	100
Efficiency (%)	95	90	87

It is clear that the technologies are in coordination with the operation of energy storage units. For instance, level 1 needs low capacity and high power technology. As a result, Li-ion battery is employed for level 1. Level 3 needs a huge capacity to transfer energy from one season to another season. As a result, pump hydro storage is considered for level 3.

The candidate places to install energy storage units are summarized in Tables VIII and IX.

In test case 1, all buses are chosen to install storage units at levels 1. The unit at level 2 has more capacity, and it is assumed that cannot be installed on the slack bus, and it can be installed on Bus 2 and Bus 3. It is assumed that the storage units at level 3 can only be installed on load bus (Bus 2). Because this storage unit mainly comprises high capacity (i.e., pump storage unit) and cannot be physically installed at every bus. In test system 2, the load buses are considered as candidate places to install storage units at level 1. Also, the storage units at level 2 and 3 mainly have high capacity. As a result, the candidate places for these storage units are restricted, and the buses with high demand are selected to be equipped with these storages. This network has two area including low-voltage and high-voltage areas. It is assumed that the storage units at level 3 can only be installed on high voltage area. Moreover, due to its huge capacity, it cannot be installed at any place of the network. As a result, only one bus at high voltage area is selected as the candidate place for this unit.

## V. SIMULATION RESULTS AND DISCUSSIONS

The proposed model is implemented in GAMS software as a mixed integer linear programming and solved by CPLEX solver. A Workstation with 2.2 GHz frequency-40 cores CPU and 128 GB RAM is used to solve the problem.

Table X shows the computational time for 3-bus network. It is clear that three-level planning significantly increases the complexity of the planning and makes its solution time burden.

### A. Results of test case 1

Table XI shows the results of the planning on test case 1. Four cases are simulated and compared.

The results indicate that objective function without energy storages is 527.297 (M\$/year) and this value is reduced by 6.825 (M\$/year) following installing energy storage at level 1.

TABLE VIII. CANDIDATE PLACES TO INSTALL STORAGE UNITS IN TEST SYSTEM 1

	Candidate places
Energy storage at level 1	All buses
Energy storage at level 2	Bus 2, Bus 3
Energy storage at level 3	Bus 2

TABLE IX. CANDIDATE PLACES TO INSTALL STORAGE UNITS IN TEST SYSTEM 2

	Candidate places
Energy storage at level 1	Bus 3-5-6-8-9
Energy storage at level 2	Bus 10 and bus 20
Energy storage at level 3	Bus 19

TABLE X: COMPUTATIONAL TIME FOR 3-BUS NETWORK

No.	Case	Computational time (sec)
1	Without energy storage	2
2	With energy storage at level 1	4
3	With energy storage at levels 1-2	92
4	With energy storage at levels 1-2-3	985

The second level of energy storage also reduces the cost by 1.202 (M\$/year) and eventually, the third level can reduce the cost by 1.685 (M\$/year). Table XII shows the power and capacity of the storages installed at different levels. It is clear that level 3 comprises more power and capacity due to its technology (i.e., pump storage unit). Fig. 3 shows the locations of the installed storage units on test case 1. The results show that all buses are equipped with energy storage units.

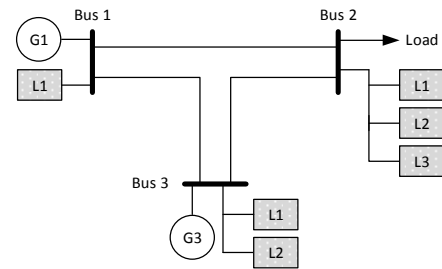

L1: storage unit at level 1 L2: storage unit at level 2  
L3: storage unit at level 3

Fig. 3. Locations of the installed storage units on test case 1.

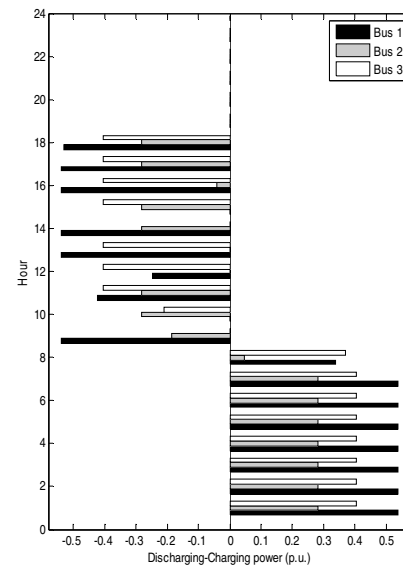

Fig. 4. Charging-discharging power for energy storages installed at level 1.

TABLE XI. RESULTS OF THE PLANNING ON TEST CASE 1

No.	Case	Objective function (Million \$/year)
1	Without energy storage	527.297
2	With energy storage at level 1	520.472
3	With energy storage at levels 1-2	519.270
4	With energy storage at levels 1-2-3	517.585

TABLE XII. ENERGY STORAGE UNITS AT DIFFERENT LEVELS FOR TEST CASE 1

	Bus	Rated power (p.u.)	Rated capacity (p.u.)
Level 1	1	0.539	4.110
	2	0.282	2.021
	3	0.406	3.211
Level 2	1	0	0
	2	0.303	2.421
	3	0.631	5.048
Level 3	1,3	0	0
	2	1.073	105.831

TABLE XIII. OPERATION OF ENERGY STORAGES INSTALLED AT LEVEL 2 ON BUS 2

Charging powers										
Hour										
Day \ Hour	1	2	3	4	5	6	7	8	24	
2	0.3	0.30	0.30	0.30	0.30	0.30	0.30	0.21	0.09	
5,7	0.3	0.30	0.30	0.30	0.30	0.30	0.30	0.30	0	
Discharging powers										
Hour										
Day \ Hour	9	10	11	12	13	14	15	16	17	18
1	0.06	0.3	0	0.3	0.30	0.30	0	0.30	0.30	0.30
3	0	0.3	0.3	0	0.30	0.30	0.30	0.06	0.30	0.30
6	0.06	0.3	0	0.3	0.30	0	0.30	0.30	0.30	0.30

TABLE XIV. OPERATION OF ENERGY STORAGES INSTALLED AT LEVEL 2 ON BUS 3

Charging powers										
Hour										
Day \ Hour	1	2	3	4	5	6	7	8	22	24
1	0	0.63	0.63	0.63	0.63	0.63	0.48	0.42	0	0
2	0	0	0	0.35	0	0.63	0	0	0	0
4	0.63	0.63	0.63	0.63	0.63	0.63	0.30	0.21	0.11	0.63
6	0.63	0.63	0.63	0.63	0.63	0.63	0.63	0.63	0	0
Discharging powers										
Hour										
Day \ Hour	9	10	11	12	13	14	15	16	17	18
1,3,6	0.13	0.63	0	0.63	0.63	0.63	0.63	0	0.63	0.63

TABLE XV. OPERATION OF ENERGY STORAGES INSTALLED AT LEVEL 3

Charging at season 2										
Hour										
Day \ Hour	1	2	3	4	5	6	7	8		
1	1.05	0.59	0.712	0.752	0.752	0.712	0.29	0.337		
2	0.60	0.777	0.905	0.596	0.948	0.274	0.306	0.356		
3	0.75	0.937	1.073	1.073	1.073	1.073	0.442	0.375		
4	0.27	0.448	0.577	0.619	0.619	0.577	0.306	0.356		
5	0.81	0.975	1.073	1.073	1.073	1.073	0.539	0.536		
6	0.73	0.874	0.982	1.018	1.018	0.982	0.478	0.518		
7	0.75	0.918	1.04	1.073	1.073	1.04	0.473	0.459		
Charging at season 4										
Hour										
Day \ Hour	1	2	3	4	5	6	7	8		
1	0.97	0.508	0.633	0.675	0.675	0.633	0.193	0.225		
2	0.51	0.69	0.822	0.514	0.866	0.191	0.204	0.237		
3	0.66	0.846	0.985	1.032	0.335	0.985	0.335	0		
4	0.18	0.361	0.494	0.538	0.538	0.494	0.204	0.237		
5	0.73	0.895	1.017	1.058	1.058	1.017	0.445	0.427		
6	0.65	0.8	0.912	0.949	0.949	0.912	0.392	0.418		
7	0.66	0.836	0.962	1.003	1.003	0.962	0.376	0.347		
Discharging at season 1										
Hour										
Day \ Hour	9	10	11	12	13	14	15	16	17	18
3	1.07	0	0.24	0	0	0	0	0	1.07	0
Discharging at season 3										
Hour										
Day \ Hour	9	10	11	12	13	14	15	16	17	18
1-7	1.07	1.07	1.07	1.07	1.07	1.07	1.07	1.07	1.07	1.07

The charging-discharging pattern for storages at level 1 is depicted in Fig. 4. The storages are charged during low-peak hours and discharged during high-cost times.

The discharged powers are less than the charged power because the efficiency of the storage units is not 100% and they have been modelled as non-ideal. The charging-discharging pattern of storages at level 2 are listed in Tables XIII and XIV. It is clear that the storage systems transfers energy from low-cost days to high-cost days. Also, the difference between the discharged and charged powers is due to modeling energy losses in the storage unit. The charging-discharging pattern of storages at level 3 is also summarized in Table XV. This storage unit shifts energy from seasons 2 and 4 to seasons 1 and 3.

The initial energy of the storages is also considered as a design variables which increases the flexibility of the planning. The initial energy of the storage units at different levels is listed in Table XVI. It is clear that some units need the initial energy to provide better performance. As described in the formulation of the energy storage units, the energy of each unit at final hour of the planning horizon must be equal to the initial energy of the unit. This issue is confirmed by Figs. 5 to 7. Fig. 5 shows that energy at hour 24 for all storage units at level 1 is zero and Table XVI confirms this issue. Fig. 6 indicates the energy of storage unit at level 2 on bus 2 on day 7 (Taking into account that the operational cycle is seven days, and only the final day is depicted here). It is clear that energy at hour 24 is 2.421 as shown in Table XVI. Finally, the energy of the storage unit at level 3 on bus 2 at season 4, day 7 (only the final season and the final day are analyzed) is depicted in Fig. 7, and final energy is 34.6 as listed in Table XVI. The results show that the installed storage units do not operate at hours 19-21. This issue is due to the energy pricing format given in Table IV. The energy price at hours 1-8 is low, at hours 9-18 is high, and at hours 19-24 is moderate. Also, the objective function of the planning is to minimize the total cost of energy consumption. As a result, the planning enforces the storage units to charge energy during low-pricing hours (mainly hours 1-8) and discharge the energy during high-pricing hours (mainly hours 9-18). On the other hand, transferring energy from hours 19-24 to hours 9-18 can also reduce the energy consumption cost. But this energy arbitraging has not been utilized by the storage units. Because it needs extra capacity for storage units, but the achieved cost saving from such energy transferring is less than the cost of capacity increment.

### B. Results of test case 2

The results of the planning on test case 2 are summarized in Table XVII. It is clear that three-level planning provides better results than the other planning's. The installed energy storage units at different levels are also listed in Table XVIII. Also, Fig. 8 indicates that locations of the installed storage units on test case 2. The charging-discharging regime of the storages at level 1 is listed in Table XIX. The storages are charged during low-peak hours and discharged during high-cost times. One of these patterns is depicted in Fig. 9.

TABLE XVI. INITIAL ENERGY OF STORAGE UNITS AT DIFFERENT LEVELS

Level	Bus	Initial energy (p.u.)
	Level 1	1,2,3
Level 2	1, 3	0
	2	2.421
Level 3	1, 3	0
	2	34.6

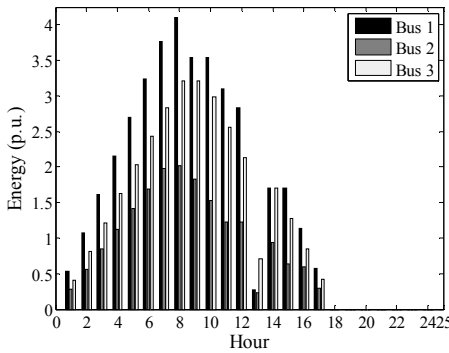

Fig. 5. Energy of the storage units at level 1 during 24-hour.

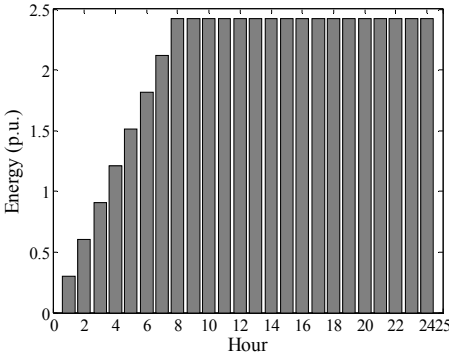

Fig. 6. Energy of the storage at level 2 on bus 2 on day 7.

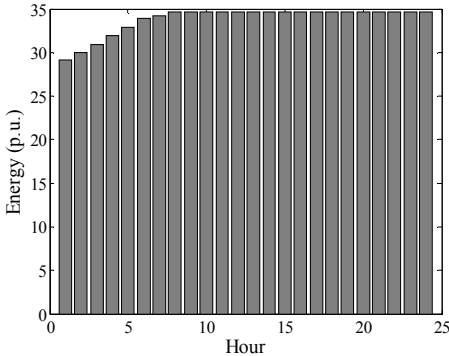

Fig. 7. Energy of storage at level 3 on bus 2 at season 4, day 7.

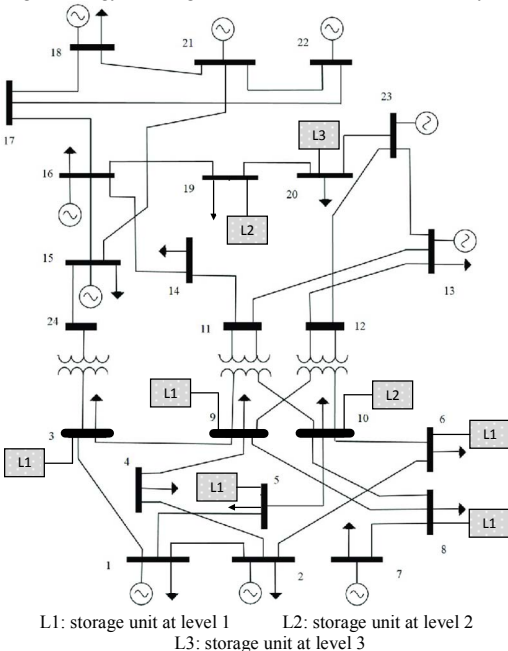

Fig. 8. Locations of the installed storage units on test case 2

TABLE XVII. RESULTS OF THE PLANNING ON TEST CASE 2

No.	Case	Objective function (Million \$/year)
1	Without energy storage	3756.246
2	With energy storage at level 1	3709.387
3	With energy storage at levels 1-2	3701.642
4	With energy storage at levels 1-2-3	3690.7910

TABLE XVIII. ENERGY STORAGE UNITS AT DIFFERENT LEVELS FOR TEST CASE 2

	Bus	Rated power (p.u.)	Rated capacity (p.u.)
Level 1	3	2.827	22.618
	5	0.632	5.059
	6	0.959	6.712
	8	1.816	12.709
Level 2	9	2.262	17.825
	10	4.065	32.518
Level 3	19	1.950	15.602
	20	6.909	681.721

There is a difference between the discharged and charged powers due to energy losses in the unit. The charging-discharging regime of the storages at level 2 and 3 are also listed in Table XX and XXI. The optimization algorithm showed that they arbitrage energy during days and seasons in order to improve the network operation and minimizing energy cost. The initial energy of the storage units is listed in Table XXII. In order to improve their operation, some units require to start from an initial energy different from zero.

## VI. CONCLUSIONS

A three-level stochastic planning was carried out to install optimal storage units in electric power systems. The proposed planning installed different storage units to minimize the total energy cost of the network. The rated power, capacity, charging-discharging regime, and initial energy for all storage levels were achieved by the planning. Two test systems were simulated. The simulation results on test case 1 demonstrated that one-level planning reduced the cost by 1.30%, two-level planning reduced the cost by 1.55%, and three-level planning reduced the cost by 1.87%. The result also confirmed that the initial energy of the storage units makes an impact on the planning, so considering this parameter as a design variable and optimizing it increased the flexibility of the planning. The simulation results on test case 2 also showed that the proposed multi-level hybrid energy storage planning could reduce the cost by about 1.8%. Further to this work, the following topics are suggested as future work; (i) considering cost of increased system complexity or maybe reduced reliability in objective function, (ii) considering initial and final SOC as different.

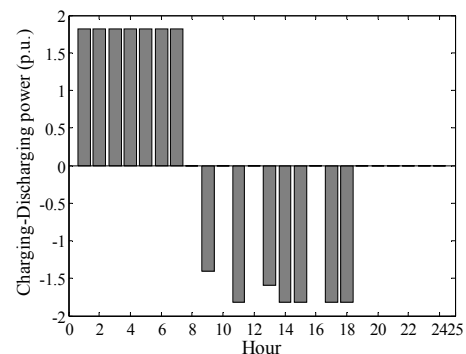

Fig. 9. Charging-discharging power for storage on bus 8 installed at level 1.



TABLE XIX. CHARGING-DISCHARGING STATES FOR STORAGES AT LEVEL 1

Bus	Charging hours	Discharging hours
3	1 to 8	9 to 18
5	1 to 8	9 to 11, 13 to 16,18
6	1 to 8	10, 12 to 16
8	1 to 7	9, 11, 13 to 15,17, 18
9	1 to 8	9 to 18

TABLE XX. CHARGING-DISCHARGING STATE FOR STORAGES AT LEVEL 2

Bus 10	Charging	Day 1	Hours 2 to 8
		Day 2	Hours 1 to 6
Discharging	Day 4	Hours 1 to 8, 19, 20, 23	
	Day 6	Hours 1 to 8	
Bus 19	Charging	Day 3,5,7	Hours 9 to 18
		Day 2	Hours 1 to 8, 22
Discharging	Day 5,7	Hours 1 to 8	
	Day 1	Hours 9 to 10, 12 to 18	
	Day 3,6	Hours 9 to 18	

TABLE XXI. CHARGING-DISCHARGING STATE FOR STORAGES AT LEVEL 3

Charging	Season 2	Day 1 to 7	Hours 1 to 8
	Season 4	Day 1 to 2, 4 to 7	Hours 1 to 8
Discharging		Day 3	Hours 1 to 6, 8
	Season 1	Day 3	Hours 10, 15 to 18
	Season 3	Day 1 to 7	Hours 9 to 18

TABLE XXII. INITIAL ENERGY OF THE STORAGE UNITS AT DIFFERENT LEVELS

	Bus	Initial energy (p.u.)
Level 1	3,5,6,8,9	0
Level 2	10	0
	19	15.602
Level 3	20	222.881

## REFERENCES

[1] H. Chen, T. N. Cong, W. Yang, C. Tan, Y. Li, and Y. Ding, "Progress in electrical energy storage system: A critical review," *Progress in Natural Science*, vol. 19, no. 3, pp. 291-312, 2009/03/10/ 2009.

[2] H. Saboori, R. Hemmati, S. M. S. Ghiasi, and S. Dehghan, "Energy storage planning in electric power distribution networks – A state-of-the-art review," *Renewable and Sustainable Energy Reviews*, vol. 79, no. Supplement C, pp. 1108-1121, 2017/11/01/ 2017.

[3] C.-H. Chen, N. Chen, and P. B. Luh, "Head Dependence of Pump-Storage-Unit Model Applied to Generation Scheduling," *IEEE Transactions on Power Systems*, vol. 32, no. 4, pp. 2869-2877, 2017.

[4] S. Shafiee, H. Zareipour, A. M. Knight, N. Amjadi, and B. Mohammadi-Ivatloo, "Risk-constrained bidding and offering strategy for a merchant compressed air energy storage plant," *IEEE Transactions on Power Systems*, vol. 32, no. 2, pp. 946-957, 2017.

[5] A. Moeini, I. Kamwa, and M. d. Montigny, "Power factor-based scheduling of distributed battery energy storage units optimally allocated in bulk power systems for mitigating marginal losses," *IET Generation, Transmission & Distribution*, vol. 10, no. 5, pp. 1304-1311

[6] M. Sedghi, A. Ahmadian, and M. Aliakbar-Golkar, "Optimal storage planning in active distribution network considering uncertainty of wind power distributed generation," *IEEE Transactions on Power Systems*, vol. 31, no. 1, pp. 304-316, 2016.

[7] A. C. Luna, N. L. Diaz, M. Graells, J. C. Vasquez, and J. M. Guerrero, "Mixed-integer-linear-programming-based energy management system for hybrid PV-wind-battery microgrids: Modeling, design, and experimental verification," *IEEE Transactions on Power Electronics*, vol. 32, no. 4, pp. 2769-2783, 2017.

[8] I. Wasiak, R. Pawelek, and R. Mienski, "Energy storage application in low-voltage microgrids for energy management and power quality improvement," *IET Generation, Transmission & Distribution*, vol. 8, no. 3, pp. 463-472

[9] Q. Tabart, I. Vechiu, A. Etxeberria, and S. Bacha, "Hybrid Energy Storage System MicroGrids Integration for Power Quality Improvement Using Four Leg Three Level NPC Inverter and Second Order Sliding Mode Control," *IEEE Transactions on Industrial Electronics*, 2017.

[10] A. K. Arani, H. Karami, G. Gharehpetian, and M. Hejazi, "Review of Flywheel Energy Storage Systems structures and applications in power systems and microgrids," *Renewable and Sustainable Energy Reviews*, vol. 69, pp. 9-18, 2017.

[11] T. Qiu, B. Xu, Y. Wang, Y. Dvorkin, and D. S. Kirschen, "Stochastic Multistage Coplanning of Transmission Expansion and Energy Storage," *IEEE Transactions on Power Systems*, vol. 32, no. 1, pp. 643-651, 2017.

[12] F. Zhang, Z. Hu, and Y. Song, "Mixed-integer linear model for transmission expansion planning with line losses and energy storage systems," *IET Generation, Transmission & Distribution*, vol. 7, no. 8, pp. 919-928, 2013.

[13] A. Lorca and X. A. Sun, "Multistage robust unit commitment with dynamic uncertainty sets and energy storage," *IEEE Transactions on Power Systems*, vol. 32, no. 3, pp. 1678-1688, 2017.

[14] Y. Levron, J. M. Guerrero, and Y. Beck, "Optimal power flow in microgrids with energy storage," *IEEE Transactions on Power Systems*, vol. 28, no. 3, pp. 3226-3234, 2013.

[15] X. Jin, Y. Mu, H. Jia, J. Wu, T. Jiang, and X. Yu, "Dynamic economic dispatch of a hybrid energy microgrid considering building based virtual energy storage system," *Applied Energy*, vol. 194, no. Supplement C, pp. 386-398, 2017/05/15/ 2017.

[16] S. Pulendran and J. E. Tate, "Energy storage system control for prevention of transient under-frequency load shedding," *IEEE Transactions on Smart Grid*, vol. 8, no. 2, pp. 927-936, 2017.

[17] X. Luo, C. K. Lee, W. M. Ng, S. Yan, B. Chaudhuri, and S. Y. R. Hui, "Use of adaptive thermal storage system as smart load for voltage control and demand response," *IEEE Transactions on Smart Grid*, vol. 8, no. 3, pp. 1231-1241, 2017.

[18] R. Hemmati and H. Saboori, "Emergence of hybrid energy storage systems in renewable energy and transport applications – A review," *Renewable and Sustainable Energy Reviews*, vol. 65, no. Supplement C, pp. 11-23, 2016/11/01/ 2016.

[19] Y. Liu, W. Du, L. Xiao, H. Wang, and J. Cao, "A method for sizing energy storage system to increase wind penetration as limited by grid frequency deviations," *IEEE Transactions on Power Systems*, vol. 31, no. 1, pp. 729-737, 2016.

[20] X. Zhu, J. Yan, and N. Lu, "A Graphical Performance-Based Energy Storage Capacity Sizing Method for High Solar Penetration Residential Feeders," *IEEE Transactions on Smart Grid*, vol. 8, no. 1, pp. 3-12, 2017.

[21] G. Ma, G. Xu, Y. Chen, and R. Ju, "Multi-objective optimal configuration method for a standalone wind-solar-battery hybrid power system," *IET Renewable Power Generation*, vol. 11, no. 1, pp. 194-202, 2016.

[22] M. Bornaipour, R.-A. Hooshmand, A. Khodabakhshian, and M. Parastegari, "Optimal stochastic scheduling of CHP-PEMFC, WT, PV units and hydrogen storage in reconfigurable micro grids considering reliability enhancement," *Energy Conversion and Management*, vol. 150, no. Supplement C, pp. 725-741, 2017/10/15/ 2017.

[23] *Power System Test Cases (www.fglongatt.org)*.

[24] "MATPOWER software (case24\_ieee\_rts)," ed.

[25] *ovo energy (www.ovoenergy.com)*.

[26] B. Zakeri and S. Syri, "Electrical energy storage systems: A comparative life cycle cost analysis," *Renewable and Sustainable Energy Reviews*, vol. 42, pp. 569-596, 2015.



**Reza Hemmati** received the Ph.D. degree in electrical engineering from Isfahan University, Isfahan, Iran, in 2013. Currently, he is an Assistant Professor with Kermanshah University of Technology, Kermanshah, Iran. His research interests include power systems planning, operation, and control.



**Miadreza Shafie-khah** (M'13-SM'17) received the M.Sc. and Ph.D. degrees in electrical engineering from Tarbiat Modares University, Tehran, Iran, in 2008 and 2012, respectively. He received his first postdoc from the University of Beira Interior (UBI), Covilha, Portugal in 2015, while working on the 5.2-million-euro FP7 project SINGULAR ("Smart and Sustainable Insular Electricity Grids Under Large-Scale Renewable Integration"). He received his second postdoc from the University of Salerno, Salerno, Italy in 2016. He is currently an Invited Assistant Professor and Senior Researcher at C-MAST/UBI, where he has a major role of co-coordinating a WP in the 2.1- million-euro national project ESRIGIDS ("Enhancing Smart GRIDS for Sustainability"), while co-supervising four PhD students and two post-doctoral fellows. He was considered one of the Outstanding Reviewers of the IEEE TRANSACTIONS ON SUSTAINABLE ENERGY, in 2014, and one of the Best Reviewers of the IEEE TRANSACTIONS ON SMART GRID, in 2016. His research interests include power market simulation, market power monitoring, power system optimization, demand response, electric vehicles, price forecasting and smart grids.



**João P. S. Catalão** (M'04-SM'12) received the M.Sc. degree from the Instituto Superior Técnico (IST), Lisbon, Portugal, in 2003, and the Ph.D. degree and Habilitation for Full Professor ("Agregação") from the University of Beira Interior (UBI), Covilha, Portugal, in 2007 and 2013, respectively.

Currently, he is a Professor at the Faculty of Engineering of the University of Porto (FEUP), Porto, Portugal, and Researcher at INESC TEC, INESC-ID/IST-UL, and C-MAST/UBI. He was the Primary Coordinator of the EU-funded FP7 project SiNGULAR ("Smart and Sustainable Insular Electricity Grids Under Large-Scale Renewable Integration"), a 5.2-million-euro project involving 11 industry partners. He has authored or coauthored more than 600 publications, including 215 journal papers (more than 60 IEEE Transactions/Journal papers), 336 conference proceedings papers, 2 books, 34 book chapters, and 14 technical reports, with an *h*-index of 35, an *i10*-index of 140, and over 5500 citations (according to Google Scholar), having supervised more than 50 post-docs, Ph.D. and M.Sc. students. He is the Editor of the books entitled *Electric Power Systems: Advanced Forecasting Techniques and Optimal Generation Scheduling* and *Smart and Sustainable Power Systems: Operations, Planning and Economics of Insular Electricity Grids* (Boca Raton, FL, USA: CRC Press, 2012 and 2015, respectively). His research interests include power system operations and planning, hydro and thermal scheduling, wind and price forecasting, distributed renewable generation, demand response and smart grids.

Prof. Catalão is an Editor of the IEEE TRANSACTIONS ON SMART GRID, an Editor of the IEEE TRANSACTIONS ON SUSTAINABLE ENERGY, an Editor of the IEEE TRANSACTIONS ON POWER SYSTEMS, and an Associate Editor of the *IET Renewable Power Generation*. He was the Guest Editor-in-Chief for the Special Section on "Real-Time Demand Response" of the IEEE TRANSACTIONS ON SMART GRID, published in December 2012, and the Guest Editor-in-Chief for the Special Section on "Reserve and Flexibility for Handling Variability and Uncertainty of Renewable Generation" of the IEEE TRANSACTIONS ON SUSTAINABLE ENERGY, published in April 2016. Since May 2017, he is the Corresponding Guest Editor for the Special Section on "Industrial and Commercial Demand Response" of the IEEE TRANSACTIONS ON INDUSTRIAL INFORMATICS. He was the recipient of the 2011 Scientific Merit Award UBI-FE/Santander Universities, the 2012 Scientific Award UTL/Santander Totta, the 2016 FEUP Diploma of Scientific Recognition, and the Best INESC-ID Researcher 2017 Award, in addition to an Honorable Mention in the 2017 Scientific Awards ULisboa/Santander Universities. Moreover, he has won 4 Best Paper Awards at IEEE Conferences.